



THE SPECIALISTS' SERIES.

A MANUAL OF
TELEPHONY.

WILLIAM HENRY PREECE, F.R.S.,
Engineer-in-Chief and Electrician, General Post Office,

AND

ARTHUR J. STUBBS,
Technical Officer, General Post Office.

LONDON :

WHITTAKER AND CO., PATERNOSTER SQUARE,
NEW YORK AGENTS : MACMILLAN & CO.

1893.



PREFACE.

IN November, 1888, was published one of the volumes of the Specialists' Series, entitled "The Telephone," the authors being W. H. Preece and Julius Maier, Ph.D. The reception extended to this work was of the most gratifying character ; but the rapid strides made in practical telephony since that time, together with the fact that Dr. Maier's services were no longer available, led to the decision that the original volume should not be re-issued, but should be replaced by the present work.

We desire here to recognise and acknowledge the use that we have made of Dr. Maier's previous labours, particularly in connection with the earlier portions of this book, which deal principally with historical telephony.

No slight difficulty has been experienced in determining what information should be given and what excluded. As, on the one hand a minute and particular description of all conditions is unnecessary for the experienced specialist ; so, on the other hand, the neglect of minor details may lead to very great inconvenience to others who, in isolated districts, wish to avail themselves of the fruits of the labours of their more favoured colleagues. We have spared no pains to secure such due proportion in the descriptions of the various apparatus and systems as shall meet the wants of both these classes.

As far as possible, where illustrations of instruments are given they are drawn as plans, etc., approximately to scale, as it is believed that this will generally be found not only to give a more correct idea of the construction, but also to make the working of the parts more certainly understood than can be the case with an ordinary view. The diagrams which show the systems of connections have been made on a uniform plan, so that differences between various systems may be the more readily traced. A large majority of the illustrations have been specially drawn by the authors for this work.

Telephony, in the broad principles of its practical application, tends increasingly to become cosmopolitan; so that, although English practice generally is more especially described, Continental systems are not excluded, and the principal points of practice in America—the home of the art—are fairly represented.

It will be seen from the table of contents that an effort has been made to classify the wide range of subjects dealt with so as to facilitate reference. With the like object the page-headings give, alternately, the subject of the chapter and that of the page; while the index, without being congested with irrelevant references, has been made with a view to include all such cross-references as appear likely to be required.

The first six chapters, which are comprised in Part I., deal with Transmitters and Receivers, theoretically, historically, and practically. In the practical section (Chapters IV. and V.) the different types have been classified; and here, as well as in other sections, references to British patent specifications are given in most cases where the apparatus is or has been so protected.

Part II. includes a chapter (VIII.) on Bells, Relays, and other complementary apparatus used with telephones; also, one (IX.) which illustrates some typical forms of complete instruments, and another (X.) which treats of some of the best plans for dealing with intermediate stations.

The next division (Chapters XI.—XIV.) will be found to contain a considerable amount of information respecting ordinary simple exchanges; while in Part IV. is taken up the wider and, in present-day telephony, more important subject of multiple switches. In our opinion it is scarcely possible to exaggerate the importance of the proper installation of a large exchange; it is, perhaps, one of the most difficult problems of telephony, requiring shrewd business ability in its inception no less than sound common sense and unflagging care in its carrying out and its maintenance. Some of the most approved details on the various matters involved will be found in Chapters XV.—XX.

The scope of Part V. is of a rather less defined character, comprising chapters on subjects—Translators and Call-offices—which are closely associated with exchange matters, together with some having a more general bearing. Among these the extension of the ordinary use of telephones brings the subject of domestic switchboards (Chapter XXVI.) into some prominence; and Chapter XXVII., on Selective Signalling, may be useful as indicating the general prospects of a subsidiary branch in telephony which has already attracted the inventive faculties of a great many minds.

Part VI., in which some points of line construction—aerial, subterranean, and submarine—are described, is necessarily far from exhaustive, but will, it is hoped, be

found to contain information which, if not new, is not very generally clearly understood.

The divergences between authorities on the electrical and other qualities of the standard gauges of copper wire have induced us to entirely re-calculate the Table given in the Appendix, and to state all the particulars on the basis of which the calculations are made.

In a work of this kind it is almost impossible to avoid occasionally giving undue notice to some matters of minor importance to the exclusion of others of more general interest. We can only say that this consideration has been present with us step by step, and that we have striven to adopt the middle course throughout. We hope that those who refer to these pages will be able to admit that our efforts have not been altogether devoid of success.

To the numerous gentlemen in the technical and practical world who have placed their knowledge and services at our disposal we express our hearty thanks as also to those from whose published works information has been drawn. As far as possible, such indebtedness is more specifically acknowledged in other places.

We shall esteem it a favour if those who detect inaccuracies will point them out, and we shall also feel obliged to any who will favour us with such other suggestions as would tend to enhance the practical value of the work.

LONDON, *July*, 1893.

CONTENTS.

	Page
INTRODUCTION	I

PART I.

TRANSMITTERS AND RECEIVERS.

CHAPTER I.

INDUCTION.

Electric Currents and Magnetic Field. Current Induction. Magneto-electric Induction. Lenz's Law. Induction Coils. Law of Induction Coil. Self-induction. Time-constant. Spurious Resistance

CHAPTER II.

THE BELL TELEPHONE.

Early Forms. Electro-magnetic. Magnetic Telephone. Later Form. Magnetic Field. Transmitter and Receiver. Action of Telephone. Theories of Action. Extreme Sensitiveness. Various Transmutations of Energy. Mercadier's Researches as to Relation of several Parts. Effect of the Permanent Magnetic Field... ..

15

CHAPTER III.

EDISON'S TRANSMITTER AND HUGHES' MICROPHONE.

Varying Resistance of Carbon under Pressure. Du Moncel's Claim. Edison's Carbon Transmitter. Relation of External Resistance to that of Transmitter. Application of Induction Coil, by Gray to the Musical Telephone, and by Edison to his Transmitter. Hughes' Microphone. Theories of Microphone. Presence of Trevelyan Effect

30

CHAPTER IV.

TELEPHONE RECEIVERS.

PAGE

Gower's; Reed Call. Siemens'; "Siren" Call. Ader's; "Over-exciter," Experimental Demonstration. D'Arsonval's. Goloubitzky's. Neumayer's. Double-pole Bell : Post-Office Terminal; Connection "Tag." "Watch" Receivers : De Jongh's. Collier's. "Head-gear"—Single and Double. Mercadier's Bi- telephone. Adjusting Clamp for Receivers	40
--	----

CHAPTER V.

CARBON TRANSMITTERS.

Carbon the only suitable Material known. Crossley's Trans- mitter. Gower-Bell. Ader. Bert and D'Arsonval. De Jongh. Mix and Genest. "Johnson." Blake. Metal-cased or Switch- board Blake. Maiche. Gent. Loch-Labye. Freeman's. Boudet. Burnley. Hunning. Moseley. Roulez. Berliner's Universal. Berthon. Thornberry. Western Electric "Solid-back." Hunning "Cone" : Deckert	60
---	----

CHAPTER VI.

EXAMPLES OF TELEPHONIC RESEARCH.

Reis' Transmitter. Reis' Receiver. Edison's Electro-motograph. Breguet's Mercury Telephone—Transmitter and Receiver. Preece's Thermo-Telephone Receiver. Forbes' Thermal Transmitter. Dol- bear's Receiver... ..	93
---	----

CHAPTER VII.

THE COMPARATIVE EFFICIENCY OF SOME TRANSMITTERS AND
INDUCTION COILS.

A. Prof. Cross' Experiments with Edison's, Blake's, and Hun- ning's. Post - Office Experiments with Gower-Bell, Berliner, D'Arsonval, De Jongh, and Mix and Genest. Artificial Line.	
B. Importance of Induction Coil. Swiss Experiments with ten Coils. Post - Office Experiments with five different Coils. Wide Variation with same Efficiency	103

PART II.

APPARATUS AND CIRCUITS.

CHAPTER VIII.

COMPLEMENTARY APPARATUS USED WITH TELEPHONES.

I. The Automatic Switch. II. Lightning Protectors. Serrated. Austrian Double. Post-Office Circular Plate : Single and Double. German "Spindle." Post - Office "Point." III. Batteries.	
--	--

Leclanché—Six-block. Leclanché-Barbier. "Dry" Cells. Secondary Cells. IV. Magneto Generators. Automatic Cut-outs; Gilliland, Williams, Ericsson-Bell, Post. Driving Gear. Working. Range of Working. Connections. Carty's System of Connections. Commutated Magneto. V. Call-Bells. Trembler. With Indicator—Post-Office Pattern, French Pattern. Continuous-Ringing. "Extension." With Automatic Cut-out. "Whittington." Circular Pattern Trembler. Magneto. VI. Pendulum Signaller. VII. Relays: Post-Office Pattern. VIII. Wall Fittings, etc: Rosettes; Wall-blocks	113
--	-----

CHAPTER IX.

COMPLETE TELEPHONE INSTRUMENTS.

Gower-Bell: Connections. Post-Office: "Universal" Connections. Arrangement of Parts. Use of two separate Automatic Switch Levers. Bell-Blake. Hunning-Bell with Magneto. Berliner "Universal" with Magneto. Ericsson-Bell Wall-set. Siemens' Battery-call Wall-set. Table Telephones: Western Electric; Mix and Genest; Ericsson-Bell; Consolidated "Circular" Pattern; Siemens' Magneto with Micro-Telephone. Micro-Telephones: Ericsson-Bell; Siemens'; Western Electric	143
---	-----

CHAPTER X.

INTERMEDIATE STATIONS.

British Post-Office System. Principles of Connection: Series; Differential; "Bridge" or "Leak." Advantages of "Bridge" and "Leak" Plan; Saving of Line when no Switch is required. System adopted by Post Office: Equalising Resistance Coils; Method of Connection; Balancing with more than three Offices in Circuit; Regulations as to use of Bells, 100-ohm Relays and 1,000-ohm Relays; Standard Ringing Current. Method of calculating Battery-power; which may be different for each Office on the same Circuit. Joint-resistance Scale; Theory of its Construction. Post-Office "Bridge" Intermediate Switch: Connections. German System and Switch for Single-wire Circuit. Three-lever Switch (Single-wire). Miller's Intermediate Switch. Single-wire "Leak" Switches: Two-lever; Post-Office Plan	156
--	-----

PART III.

SIMPLE TELEPHONE EXCHANGE SYSTEMS.

CHAPTER XI.

SWITCHBOARDS FOR SMALL TELEPHONE EXCHANGES.

Types of Switchboard: Swiss Commutator; Cord-peg and Spring. Chinnock Plan: Consolidated Company's Pattern. Danver's Indicators. Western Electric Standard Switchboards. Single-wire Switch-spring or Spring-jack. Pegs. Indicator or "Drop." System of Connections	179
--	-----

CHAPTER XII.

PAGE

SWITCHBOARDS FOR ORDINARY PUBLIC EXCHANGES;

Arrangement of Parts on Standard Switchboard. Special Fitting for Operator's Metal-cased Blake Transmitter. Single-wire Switchboard Connections. Method of Operating. Ring-off Indicator. Switching between neighbouring Switchboards. Number of Subscribers for each Operator. Dewar Table-key. Ringing Keys. Motor-Generator. Pole-changer. Application of Condenser. Peg-circuit Connections: Ring-off Indicator and Operator's Instrument in Direct or in Derived Circuit. Cam-lever Key. Single-cord Switchboards: Switch-spring; Line-peg; Operator's Peg; System of Connections. Double-wire Switchboards; Connections. Through-switching on Mixed System of Single and Double Wires. Advisability in some Cases of Wiring all Boards for Metallic-circuit Working.

Through-switching between Sections. Number of Wires required. Decreasing Proportion of Direct-Switching Operations with Increase in Number of Subscribers. De la Touanne's Formula for calculating Proportions of Direct Switchings. Different Methods of manipulating Through-connections.

Bennett's Ring-through System 189

CHAPTER XIII.

THE ENGLISH POST-OFFICE SYSTEM.

Form of ordinary Switchboard. Peg. "Polarised" Indicator. Ordinary System of Working—Metallic-circuit "Bridge." Switch Connections. "Permanent Current" Working—Its Advantages. Calling by "Buzzer." Arrangement of Apparatus at small Exchange. Speaking Tablets. Switchboard Telephone. Through Tablets.

Intermediate Offices. Exchange Intermediate Switch—two "Positions" only. Connections.

Trunk Wires. Time Limit. Management of Exchanges.

Numbers *versus* Names. Grouping of Subscribers. Repetition of Messages. Checking Accuracy of Names and Numbers. Night Service. Time Average. Switching Duty. Testing Switch-cords. Silence Cabinets and Fittings—Arm-rests. "Telegraph" Message Work. Special Connections for Departmental Single-wire Switches. Telephone Galvanometers. Winding of Instrument Coils... .. 213

CHAPTER XIV.

EXCHANGE "CALL-WIRE" SYSTEMS.

(a.) The Law Call-wire Plan.

Invented by Frank Shaw. Principle of System. Method of Working.

(b.) The Mann Call-wire Plan.

Modification of "Law." Comparison of two Plans. Connections of Subscriber's Instrument, Method of Working. Use of Indicators on Direct Circuit. Group Connections at Exchange. Night Service.

	PAGE
(c.) <i>Miller's Call-wire Plan.</i>	
Further Modification. Effect of Faults in Call-wire. Abolition of Indicators.	
(d.) <i>Bennett & Maclean's Call-wire Plan.</i>	
Application of "Ring-through" Device. No special Call-wire needed. Method of Working	233

PART IV.

MULTIPLE SWITCHES.

CHAPTER XV.

SINGLE-WIRE MULTIPLE SWITCHBOARD.

Importance of "Multiple" Principle : illustrated by Comparison of Working 6,000-line Exchange. Comparison of Ordinary and Multiple Systems. General Arrangement of Standard Multiple Board. "Local" or "Individual" Springs. Accessibility and Compactness. Switch-strip. Line-connections. "Engaged" Test. Peg-connections. System of Working. Simplicity. Size of Section of Switch. "Ultimate Capacity." Numbering. Apportionment of Subscribers to each Section. Number of Operators for each Section. Method of Working. Number of Pairs of Pegs for each Section—varying Practice. Arrangement of Subscribers. Spare Switch-holes. Limit of Ultimate Capacity. Terminal Half-sections of Multiple Panels.

Single-cord Multiple Switchboard.

Substitution of Key and Earth-switch for Table and Ringing Keys. System of Working. Provision for Faults in special Parts. Advantage and Drawbacks of System.

Oesterreich's Multiple Switch.

Simplicity of Switch-strips. Permanent Current from Exchange, Double and Single Pegs. Galvanoscope. Disposition of the higher Rows of Strips

247

CHAPTER XVI.

MULTIPLE SWITCHES FOR METALLIC CIRCUITS.

(a.) System with Single-spring Switch-holes.

Simplicity of Transition from Single-wire to Metallic Circuits if suitable Provision has been made. Peg-circuit Connections. Method of Working. Engaged Test.

(b.) Switch with Distinct "Engaged Signal" Circuit.

Disadvantages of Earth-connection on Metallic Circuit. National Telephone Company's Device. How applied. Direct Earth-connection. Double-Winding of Operator's Telephone Coils.

	PAGE
(c.) <i>Western Electric "Branching" System.</i>	
Indicators in "Bridge." No Break at Line-Contacts. "Self-restoring" Indicators. General Arrangement of Parts. Spring-strip. Three-Connection Peg. Construction and Action of Self-restoring Indicator. Line-connections and System of Working. Peg-circuit. Engaged Test and Ring-off Signal. Table and Ringing Keys.	268

CHAPTER XVII.

POST-OFFICE MULTIPLE SWITCH.

Special Conditions : Permanent Current ; Secrecy and Prevention of Triple-switching. Switch-block. Pegs : "Ordinary" ; "Detector" and "Instrument." Indicators : Non-polarised Relays. Three Positions of Polarised Needle. Renter's Telephone. Special Connection Device for Induction Coil. Line-circuit Connections. Short-circuit Wire—Device for Prevention of "Triple-switching." "Tapping" of Lines impossible. Instrument Peg : Value of Four Sections. Connections of Instrument Peg Circuit : Detector Peg and Detector. Intermediate Office : Two-position Switch. Trunk Wires. System of Working. Intercommunication.	284
--	-----

CHAPTER XVIII.

MULTIPLE SWITCH WITH CALL-CIRCUIT SYSTEM.

Switch-tablets. Pegs. Horizontal Switches. Head-gear Receivers and Breast Transmitters. Peg-circuit Connections. Test-thimble. Method of Working. Improved System. Double-wound Induction Coils	298
--	-----

CHAPTER XIX.

WIRING OF SWITCHBOARDS.

Difficulties involved : Limited Space. Form of Cables : "Twisted Pairs." Plan adopted for connecting-up the Cables. Varying Lengths of Branching Wires. Cable Racks behind Switchboards. London Pattern of National Company's System. Connections for "Local" Strips : Advantages and Disadvantages of Consecutive Connection.	305
--	-----

CHAPTER XX.

TEST-BOARDS, ETC.

Early Forms of Test-board and Cross-connecting or Distributing Board. Practical Use. Later American Plan with Soldered Connections. Lightning Protectors. Cross-connecting Wires. Utility of the various Parts. Testing Facilities. Metallic-circuit System. Position of Test-board with regard to Lines and Switch. Cabinet for Test-strips, etc. Re-arrangement of Subscribers : Intermediate Distributing Board. Systems of Testing at Telephone Exchanges.	314
--	-----

PART V.

MISCELLANEOUS SWITCHING AND OTHER SYSTEMS.

CHAPTER XXI.

TELEPHONE TRANSLATORS OR TRANSFORMERS.

Connections between Metallic and Single-wire Circuits. Bennett's Translators. Proportion between Coils. "Liverpool" Translator. Reduced Efficiency by Use of Translators. Coleman and Jackson Combined Indicator and Translator. Electrical Connections. Elsässer's Plan. Ringing-through with Voltaic Currents. Working a Mixed System of Metallic Circuits and Single Wires: "Outgoing" and "Incoming" Wires. Number of Trunk Wires for each Operator. 331

CHAPTER XXII.

TELEPHONE CALL-OFFICES.

Terms for Use of Call-offices. Practice where there is an Attendant in Charge. Forms of Silence Cabinets. Post-Office Plan; Counter-communication Switch. Time-check. London Stock Exchange Call-office System.

Automatic Call-boxes. Smith and Sinclair's. Provision for Checking Payment. Key for Free Use. Modification of Smith and Sinclair's Ordinary System. Local-circuit with Bell. Cotterell's—no Electrical Device. Poole and McIver's: Timing Length of Conversation. Mix and Genest's: Refunding Device. Blakey, Emmott & Co.'s. Proposed Toll System of Paying for Use of Ordinary Telephone Circuit 341

CHAPTER XXIII.

MULTIPLEX TELEPHONY.

Difference between Problems of Multiplex Telegraphy and Multiplex Telephony. American Plan of Working two Telephone Circuits on two Wires. Jacob's System for two Distinct Circuits. Jacob's System for four Circuits on four Wires. Rosebrugh's Plan. ... 352

CHAPTER XXIV.

SIMULTANEOUS TELEGRAPHY AND TELEPHONY.

Induction and Leakage Interference of Telegraph Signals with Telephone Lines. Due principally to sudden Rise or Fall of Potential. Van Rysselberghe's Device for reducing Interference. Applica-

tion of Device to Simultaneous Working of Telegraph and Telephone on one Circuit. Need of applying retarding Apparatus to all neighbouring Circuits. Two Telegraph Lines for one Metallic Circuit for Telephone. Disadvantages for English Practice. Picard's System. Induction Call for Superimposed Systems. Other Workers—C. F. Varley, Elisha Gray, Edison, Cardew, etc. : Recent Experiments on Paris-London Circuits. Cailho's Method	356
--	-----

CHAPTER XXV.

MILITARY TELEPHONY.

Limits of Usefulness. Valuable in Permanent Camps. Use as a Telegraphic Receiver. "Swiss Commutator" Switches preferred. Messages treated as Telegrams. Portable Telephones at Firing-points of Rifle-ranges. Cardew's "Vibrator" System. Unaffected by leaky or even broken Line. Combination with Speaking Telephone. Advantages of Cardew's System for Field-work. Disadvantages for Commercial Telegraphy. Superimposing Vibrator System on Morse Circuit—"Separators." Introduction of Temporary Intermediate Station	364
---	-----

CHAPTER XXVI.

DOMESTIC SWITCHBOARDS.

Consolidated Switchboard. Automatic Restoration to Normal Position. Simultaneous Conversation possible between several Pairs. Western Electric Pattern. The Anders-Elliott Form. "Line Selectors." Limited Number of Connections at certain Points. Use of one Battery for ringing at all Stations. Sloper's "Secret" System	373
---	-----

CHAPTER XXVII.

SELECTIVE OR INDIVIDUAL SIGNALS.

Small average Use of a Telephone Circuit by one Subscriber. Conditions required for good Selective Signal System. Early Recognition of Principle. Highton's Combined-Circuit Arrangement. Highton's Device with two Wires and Currents varying in Strength and Direction. Wilde's Step-by-step System. De Bonneville's Suggestion of Synchronised Clocks. Pendulum Selectors invented by Bizot. Ader's System—representative of Current-regulated Devices. Ericsson's Automatic Switchboard—Step-by-step Arrangement. Johnston Stephen's System—Pendulum-call Plan. Post-Office Secret System—Independent Action of any Subscriber	386
---	-----

PART VI.

CONSTRUCTION, WIRES, AND CABLES.

CHAPTER XXVIII.

CONSTRUCTION OF LINES.

Injurious Results of bad Insulation. Distance between adjacent Wires. Metallic Circuits. Use of Diagonal Wires of square to prevent inductive Disturbance from other corresponding Lines. Hughes' Suggestion of Twisted Wires, Moseley's Practical Application—the Open-wire Symmetrical Twist. Post-Office Method of identifying Twisted Wires at any Point. Insertion of extra Supports after Numbering. Equal Lengths of Span desirable. "Cross-over" System. Principle upon which Crossing-points must be decided. French Twist System.

Regulation of Sag of Wires. Draw-tongs. Tension-ratchet and Dynamometer. Stress on Wire variable with Temperature. Post-Office Table of Sags and Stresses to be observed in erecting Iron and Copper Wires at various Temperatures. Formulæ for same. To be applied to average Span and Temperature. Rule where Iron and Copper are used on same Line of Poles. Equalisation of Stress by Flexibility of Supports. Elasticity of Wire. Provisional Discretion in erecting new Lines. Determining Sag by Sight. Effect of Snow Deposits: heavier on Copper than on Iron Wire.

Joints: Britannia; German Plan; McIntire Sleeve. Length and Weight of Jointing Wire for Britannia Joints. Weight of Jointing Wire per Mile and per Ton of Line Wire. Copper Wire-binder. Post-Office Copper Tape-binder.

Suspension of Aerial Cables. Formula for Strength of suspending Wire. Attachments for suspending Wires, German Pattern. Hoop-iron Hanger. Patterson's Hanger. Raw-hide Hanger(Glover's form). Method of running Aerial Cable. Junction of Aerial Cable with Open-work.

Earth-connections. Main-pipe of Water-supply. Gas-pipes to be avoided. Pump or special buried "Earth-plate." Same Description of Earth-connection at each end of a short Line desirable. Resistance of an "earth" 409

CHAPTER XXIX.

WIRE FOR TELEPHONE AERIAL LINES.

Different Materials used for Line-wires and their Properties. Steel Wire for Over-house Lines not desirable. Galvanising. Further Protection by Hemp or Tape Covering. Important Qualities of Copper Wire. Electro-static Capacity under various Conditions. Terrestrial Disturbances.

Need for special Care in Manufacture and Use of Copper Wire. Post - Office Copper Wire Specification. Silicium : bronze and Phosphor-bronze... .. 437

CHAPTER XXX.

TELEPHONE CABLES.

Extension of Use of Cables. Use of two Wires very desirable. Preece's Tin-foil Shielded Wire: Reason of its Efficacy. Requirements for Aerial Cable. Underground Cables: Various Devices. Post-Office Aerial Cable. Post Office Four-wire Underground Cable. "Paper" Cables: British Insulated Wire Company's make. Particulars of "Conference Standard" for Cables. Patter-son Cables. Terminal Tablet. Glover's Cables: Anti-induction; Double-pairs; Improved Rubber-covered Cables. "Numbering" Devices. Fowler-Waring Cables. "Dry Core." Drawing-in. Felten and Guilleaume's Cables: Fibre; Paper; Submarine. "Beaded" Cable (Fortin-Herrmann's)	448
---	-----

CHAPTER XXXI.

ON THE LIMITING DISTANCE OF SPEECH.

"Time-constant" of a Circuit. Limiting Conditions—Retardance. Kelvin's Law. K R Factor. Limiting Factor for various Wires. Formula for Speaking Efficiency of given Circuit. Formula for Limit of Distance with given Conditions. Explanation of Differences in K R for different Conductors. Kempe's Investigation of Fact that Working Speed of Cable Metallic Circuit is the same as that of Single Wire of same Cable. Mutual Induction. London-Paris Telephone Circuits. Particulars of Cable used. Value of "Effective" as compared with "Measured" Capacity	472
---	-----

APPENDIX.

JOINT-RESISTANCE SCALE	485
STANDARD WIRE GAUGE	486
WEIGHT OF CIRCULAR WIRES, ETC.	489
CONVERSION TABLE FOR DECIMAL SYSTEM	490
INDEX	495

MANUAL OF TELEPHONY.

INTRODUCTION.

THERE is perhaps nothing more astonishing in the annals of science than the way in which the use of the telephone has developed. In July, 1877, one of the authors of this book brought the first pair of practical telephones to Europe. It is not too much to say that there are now more than a million in daily use.

The idea of transmitting sound to a distance may be traced back to remote antiquity; it found its first practical expression in the construction of the speaking-tube, and in more modern times in that of the "string" telephone.

It was to this latter instrument that Robert Hooke referred when, in 1667, he described how, by the help of a tightly-drawn wire bent in many angles, he could propagate sound to a very considerable distance.

Again, Wheatstone invented an instrument for transmitting sounds, which was described in the "Repository of Arts" for September, 1821. Wheatstone actually called his instrument the *telephone*, and the article describing it shadowed forth the principle of that special application which is now known as the "theatrophone."

This book, however, has to deal rather with the *electrical* reproduction of speech; and even the origin of this invention may be dated as far back as 1837, when an American, named Page, found that a magnetic bar would emit sounds when exposed to rapid alternate magnetisations and demagnetisations. By rapidly approaching the poles of a horse-shoe magnet to a flat spiral coil traversed by a current, he obtained a sound which was termed the "magnetic tick." De la Rive, Gassiot, and Marrian¹ observed the same phenomenon in a soft-iron bar surrounded by a helix at the moment when this helix was traversed by a current.

In 1854 Charles Bourseul, a Frenchman,² published a paper on the electric transmission of speech, in which he says:—

"Suppose that a man speaks near a movable disc, sufficiently pliable to lose none of the vibrations of the voice, and that this disc alternately makes and breaks the current from a battery; you may have at a distance another disc which will simultaneously execute the same variations.

. . . . It is certain that in a more or less distant future, speech will be transmitted by electricity. I have made experiments in this direction: they are delicate, and demand time and patience, but the approximations obtained promise a favourable result."

Philip Reis, of Friedrichsdorf, wrote in 1868:—
 "Incited thereto by my lessons in physics in the year 1860, I attacked a work begun much earlier concerning the organs of hearing, and soon had the joy to see my pains rewarded with success, since I succeeded in inventing an apparatus by which it is possible to make

¹ Guillemin, "Le Monde Physique," tome iii., p. 730.

² Du Moncel, "Applications de l'Electricité," 1854.

clear and evident the functions of the organs of hearing, but in which also one can produce tones of all kinds at any desired distance by means of the galvanic current, I named the instrument 'Telephon.'"³

Reis's instrument was in the first instance only intended for the reproduction of musical sounds—in fact, a *musical* telephone, and its possible application to the transmission of speech was of a very limited kind; but it contained the essential feature of the present telephone, and it certainly was capable of transmitting speech.

For sixteen years the question of articulating telephony was dormant. During that time improvements were made in the musical telephone by Yeates and Van der Weyde, by Cecil and Leonard Wray; and various instruments were constructed by Varley, Pollard, Garnier, and Elisha Gray; but on February 14, 1876, the speaking telephone was patented in the United States by Graham Bell. By a strange coincidence, Elisha Gray applied for a patent on the very same day for an instrument of a similar kind. Bell, with far-sighted energy, worked out and perfected his system: Gray allowed his to sleep in the American Patent Office. The question of priority between the two inventors was subsequently fought in the law courts, and ended in a compromise, one company taking up the patents of both.

At the meeting of the British Association of 1876, Lord Kelvin (then Sir William Thomson) said: "In the Canadian department I heard: 'To be or not to be, . . . there's the rub,' through an electric wire; but, scorning monosyllables, the

³ "Philip Reis," by Sylvanus P. Thompson, 1883.

electric articulation rose to higher flights, and gave me passages taken at random from the New York newspapers: 'S.S. *Cox* has arrived.' (I failed to make out the S.S. *Cox*); 'The City of New York,' 'Senator Morton,' 'the Senate has resolved to print a thousand extra copies,' 'The Americans in London have resolved to celebrate the coming fourth of July.' All this my own ears heard spoken to me with unmistakable distinctness by the thin circular disc-armature of just such another little electro-magnet as this which I hold in my hand. The words were shouted with a clear and loud voice by my colleague-judge, Prof. Watson, at the far end of the line, holding his mouth close to a stretched membrane, such as you see before you here, carrying a little piece of soft iron, which was thus made to perform, in the neighbourhood of an electro-magnet in circuit with the line, motions proportional to the sonoric motions of the air. This, the greatest by far of all the marvels of the electric telegraph, is due to a young countryman of our own, Mr. Graham Bell, of Edinburgh and Montreal and Boston, now becoming a naturalised citizen of the United States. Who can but admire the hardihood of invention which devised such very slight means to realise the mathematical conception that, if electricity is to convey all the delicacies of quality which distinguish articulate speech, the strength of its current must vary continuously as nearly as may be in simple proportion to the velocity of a particle of air engaged in constituting the sound?"

At the meeting of the same Association at Plymouth, the next year, Mr. Preece exhibited in public, for the first time in England, Bell's developed telephone, which he had just brought from the United States; and at the

same meeting Professor Bell himself gave further illustrations.

As it then stood Bell's telephone had to act both as *transmitter*, into which the words were spoken, and as *receiver*, from which, when it was applied to the ear, the words spoken into the transmitter would be heard.

So far as the receiver is concerned, the telephone has remained virtually the same as it is described in Bell's patent; alterations have been made, some obviously only with the object of evading patent rights, and others with a view both to increased convenience or greater efficiency, but in essential principle every successful receiver hitherto introduced is covered by Bell's invention.

It is, however, quite a different matter with the transmitter. The original Bell instrument, which was identical with the receiver, has been almost completely superseded as a transmitter. In its place some form of *carbon transmitter* is now generally used.

The invention of the first carbon transmitter is due to Edison, who constructed it in 1877, shortly after Bell's discovery. In this instrument the vibrating plate abuts against a button of carbon. Edison ascribed the effects obtained to a variation of electrical resistance consequent upon variation of pressure.

A still further impetus was given to telephony by the discovery of the microphone by Hughes, in 1878. He showed that the effect of Edison's carbon transmitter was not due to any influence of varying pressure on the mass of the carbon, but was a phenomenon of loose contact, and we may safely say that Hughes has done

as much for the perfection of the telephone as Bell has done towards calling it into existence.

Such were the beginnings of the electric telephone, the later development of which it will be our duty to describe and explain.

PART I.

TRANSMITTERS AND RECEIVERS.

CHAPTER I.

INDUCTION.

AN electric current always gives rise to certain magnetic conditions in its neighbourhood, which vary with its direction, its strength, and the rate at which the strength varies. The direction of a current is defined conventionally by reference to that which flows from the copper to the zinc pole outside a Daniell cell, called the *positive* current. The strength of a current is measured by the intensity of the magnetic effects which it produces in its neighbourhood, or its *magnetic field*, as the space is called in which it exerts influence. Faraday, who introduced this term, has shown how we can indicate the intensity and direction of this field by assuming it to be filled by lines whose direction is that along which a very small, theoretical, perfectly free north pole would be moved if placed in the field. The number of lines per unit area in a plane at right angles to their direction would then be made proportional to the intensity of magnetic force in the field; and this intensity is found to vary inversely as the square of the distance from the conductor. The space around a conductor through which a current is flowing can thus be mapped out by circles having the

axis of the conductor for their centre, and the effect is such that if the positive current were passing along the conductor away from the observer, then a north pole would tend to move along any one of these assumed curves of force in a direction similar to the motion of the hands of a watch facing the observer. A south pole would, of course, be urged in the opposite direction; but as the opposing poles of a magnet cannot be separated it follows that when, by the proximity of a straight conductor in which a current is passing, the two poles of a magnet are brought under the influence of the opposing forces, the magnet will tend to take up a position at right angles to the direction of the current and tangential to the lines of force. The *direction* of deflection may be easily remembered by assuming that as one looks at the face of a watch with the current passing in a direction *away* from the observer; then the north pole of a magnet will be "negatively rotated," or moved in the same direction as the hands of the watch. Of course, reversing the direction of the current will have the effect of reversing the direction of deflection. Also, assuming the current to take a circular path in the direction of the hands of the watch around a straight iron bar, then the bar will be magnetised with the north pole *away* from the observer.

Now currents and magnetic fields are so related that any change in the current produces a change in the magnetic field, and also any change in the magnetic field produces a change in the current; and this latter is true even when the change of magnetic field is due to a change in the current reacted upon. In fact, if there be a magnetic field, and a conductor in that field, any change in that field will produce the conditions that

determine a current in that conductor. Indeed, it is correct to say that if a conductor forming part of a closed circuit be moved *across* a magnetic field in a direction at right angles to the lines of force in that field, a current will be induced in that conductor whose strength is proportional to the strength of the field and to the rate at which the conductor cuts the lines of force; and conversely, if the conductor be fixed and the lines of force of the field be projected at right angles to the conductor, a current will be induced in the conductor whose strength is proportional to the intensity of the field, and to the rate at which the lines of force are projected through the field. Thus, motion either of the conductor or of the magnetic field results in an electric effect due to *induction*.

There are two classes of induction: that in which changes of the current in a primary conductor produce secondary currents in itself or in a neighbouring conductor, called *electrodynamical* or *current-induction*; and that in which changes in the magnetic field induce currents in a conductor situated in that field, called *magneto-electric induction*. The latter effect can be produced either by the motion of a permanent magnet or of an electro-magnet, or by the motion of a conductor in which a current is passing, or by the motion of the armature of a magnet.

The magnitude of the effect produced is the same with the same conditions, whether the change in the primary inductor be made slowly or quickly, but if made slowly, the longer period in which it acts necessarily involves the effect being less evident at any given time.

The direction of the secondary current in every case is determined by Lenz's law, which asserts that such a

current produces effects which tend to oppose those of the prime inducer. Thus, an increase of the current flowing in a primary conductor induces a current in a parallel secondary conductor in the *opposite* direction, while a decrease induces a secondary current in the *same* direction. Similarly, any approach of the primary current towards the secondary circuit induces a secondary current in the opposite direction, and the withdrawal of the primary circuit induces a secondary current in the same direction. Or again, for magneto-induction, if a mass of iron be made to approach a magnet surrounded by a coil of wire which constitutes a closed circuit, then the current induced in the coil will be in a direction tending to reduce the attractive force of the magnet.

Secondary currents induced from a varying primary current constitute the most effective means of securing telephonic communication, and for this purpose an *induction coil* is used. Such a coil consists usually of an iron core (made up of a bundle of soft-iron wires to facilitate rapid magnetisation and demagnetisation), surrounded by a few convolutions of thick primary wire of small resistance, which in its turn is surrounded by a large number of convolutions of fine secondary wire. Theoretically, in a perfect coil the energy in the primary and secondary circuits should be equal, but through mechanical and electrical defects this perfection cannot be quite reached. Now the energy (W) of a current in a coil, at any moment, is expressed by the product of the current (C) and of the electromotive force (E) at the terminals of the coil, that is $W = EC$. Hence, in a theoretically perfect coil,

$$E_1 C_1 = E_2 C_2$$

or

$$\frac{E_1}{E_2} = \frac{C_2}{C_1}$$

1 and 2 indicating respectively the primary and secondary circuits.

Now, all the convolutions being practically equal and in the same field, may be considered as equally affected; hence, if e be the electromotive force for each turn of wire in each coil, and $n_1 n_2$ the number of turns, then

$$\begin{aligned} & \text{and} & \frac{E_1}{E_2} &= \frac{n_1 e}{n_2 e} \\ & \text{therefore} & \frac{E_1}{E_2} &= \frac{C_2}{C_1} = \frac{n_1}{n_2} \end{aligned}$$

from which it is evident that the ratios of the electromotive force at the ends of the two coils can be varied at will by the variation of the relative numbers of convolutions of the coils.

There is a remarkable cause of disturbance to this theoretical perfection in the presence of a secondary effect in all coils, due to electro-magnetic inertia. If a current be passed through a coil and one convolution of the coil be considered, this will set up a magnetic field which will project lines of force through every other turn of the helix in such a direction as to set up an opposing E.M.F. to the prime current; and every other turn will act in the same way, so as to tend to set up a total E.M.F. opposing the flow of the prime current to a degree which will vary with the square of the number of turns (n^2). When the prime current ceases the reverse action takes place, the electromotive force excited by the motion of the lines of force in the opposite direction, acts in the same direction as the prime current, and tends to prolong its flow. This effect of *self-induction* is to retard the rate of increase of current at its commencement and its rate of decrease at its cessation, and so to modify the production of secondary currents.

It is considerably influenced by the mass and arrangement of the iron present, and hence the use of bundles of soft-iron wire as a core to facilitate the rapid disappearance of the magnetic field.

The effect of self-induction is very marked with periodic currents of rapid alternations, and it will be found that this materially affects the clearness of articulation of telephones, and seriously reduces their efficiency. Its effect is not confined to one helix or to the apparatus, but extends to the whole circuit, in which it is not possible to establish a current instantaneously at its maximum strength, or to let it suddenly cease to flow. Hence, self-induction limits the number of currents which can be transmitted per second. Every circuit, whether in the form of a coil or not, has a co-efficient of self-induction, called L , and a time-constant which $\frac{L}{R}$ enables calculations to be made to determine the effect of electro-magnetic inertia. The opposing E.M.F. set up acts as a resistance, and it is sometimes called a *spurious* resistance. It differs from pure resistance in the fact that it does not dissipate energy by developing heat; it stores the energy up, or renders it potential. It throttles or chokes a coil when conveying periodic currents—an injurious effect which is in practice made to serve a useful purpose.

CHAPTER II.

THE BELL TELEPHONE.

PROFESSOR GRAHAM BELL'S Patent Specification for Great Britain (No. 4,765) was filed December 9th, 1876, by Morgan Brown, as a "communication from abroad."

The first form of the instrument,¹ constructed by Bell in 1876, is shown in fig. 1. A harp of steel rods *H* was attached to the poles of a permanent magnet *N S*. When any one of the rods was thrown into vibration, undulatory currents were induced in the coil of the electro-magnet *E* through the disturbance of the magnetic field in which it was placed, which, passing by the wire *L* to the electro-magnet *E*₁, by varying its magnetism, attracted the rods of the harp *H*₁ with varying force, and threw into vibration that rod which was in unison with the one vibrated at the other end of the circuit. Not only were they in unison, but the amplitude of vibration of the one determined the amplitude of vibration of the other; for the strength of the induced currents is determined by the amplitude of the disturbing vibration, and the amplitude of the

¹ "Journal of the Society of Telegraph Engineers," 1877, vol. vi., p. 403.

vibration at the receiving end depends upon the strength of the induced currents. By singing into a piano, certain of the strings of the instrument are set into vibration sympathetically by the action of the voice with different degrees of amplitude, and a sound which is an approximation to that uttered is produced from

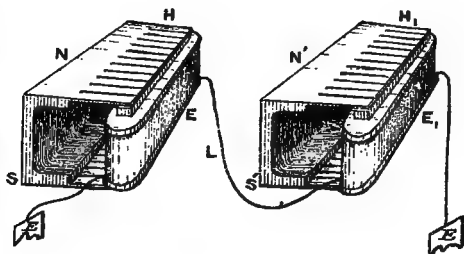

Fig. 1.

the piano. Theory shows that, if the piano had a much larger number of strings to the octave, the vowel sounds would be perfectly reproduced. It was upon this principle that Bell constructed his first telephone. The expense of constructing such an apparatus, however, deterred him from proceeding further in this direction, and compelled him to seek for a simpler method.

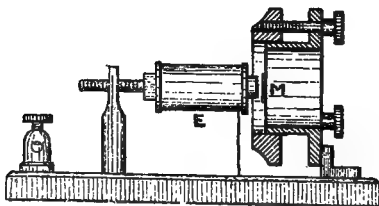

Fig. 2.

After many experiments with more or less unsatis-

factory results, he constructed the instruments shown in figs. 2 and 3, which he exhibited at Philadelphia in 1876.

In this apparatus the transmitter (fig. 2) was formed by an electro-magnet E, through which a current flowed, and a membrane M, made of gold-beater's skin, on which was placed as a sort of armature a piece of soft iron, which thus moved in front of the electro-magnet when the membrane was thrown into sonorous vibration.

The receiver (fig. 3) was formed of a tubular

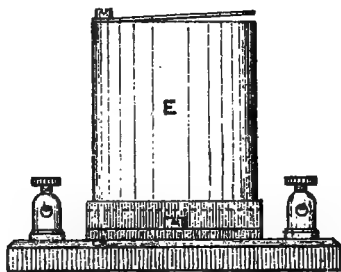

Fig. 3.

electro-magnet E, consisting of a vertical single-coil electro-magnet, enclosed in a soft-iron tube, upon which was fixed by a screw a thin armature of sheet iron, slightly tilted as shown, which acted as a vibrator; a small bridge, upon which the electro-magnet was fixed, acted as a sounding-box.

It must, however, be remarked that the apparatus thus constructed was not a magnetic telephone pure and simple, for, as stated, a battery of several cells was placed in circuit. It was, however, of great service, as it enabled Bell and his friend Watson to experimentally

study telephonic transmission. This was the instrument that Lord Kelvin saw in 1876 (p. 3).

After numerous experiments made with the object of discovering empirically the exact effect of each element of the combination, the membrane of goldbeater's skin used in the transmitter (fig. 2) was discarded, and a simple iron plate used instead, and further—and this is the most important point in the improved apparatus—Bell superseded the battery by a permanent magnet to produce the magnetic field. This, indeed, appears to have been his original idea, as is indicated in his first telephone (fig. 1).

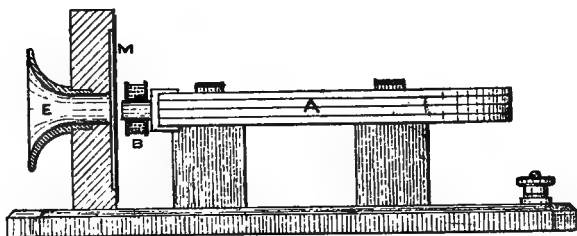

Fig. 4. $\frac{1}{2}$ full size.

In its new form the telephone consisted of a permanent bar magnet with a coil of fine wire at one end, suitably mounted in a wooden box behind a thin iron diaphragm; but a still more effective form of apparatus was constructed by using a powerful compound horse-shoe magnet in place of the straight rod which had been previously used. As shown in fig. 4, upon each pole-piece of this magnet was fitted a small coil B, and the diaphragm M—a thin iron disc—was fixed on a separate block in front. On the side of the block next the diaphragm was a shallow cavity to leave M free to

vibrate, and a hole through the block communicated with a mouth or ear piece E. By loosening two clamping-pieces the position of the magnet A could be adjusted with regard to the diaphragm.

This, which was really the first practical magnetic telephone, was exhibited in the Essex Institute, in Salem, Massachusetts, on the 12th February, 1877, on which occasion a short speech shouted into a similar telephone in Boston, 16 miles away, was heard by the audience in Salem, while their enthusiastic applause was distinctly heard at Boston.

From the form shown in fig. 4 to the next form of the instrument (fig. 5) is but a step. It is, in fact, the same arrangement in a portable form; a bar magnet being placed inside a handle, and a more convenient form of mouthpiece provided. Professor Peirce, of Brown University, Providence, was the first to demonstrate the extreme smallness of the magnets which might be employed, and he also devised the form of mouthpiece shown in fig. 5.

In this, the latest form given to it by its inventor, the instrument consists of a small wooden case, which contains the magnet, N S, placed with one pole opposite the vibrating plate D, and serves at the same time for holding the instrument in the hand.

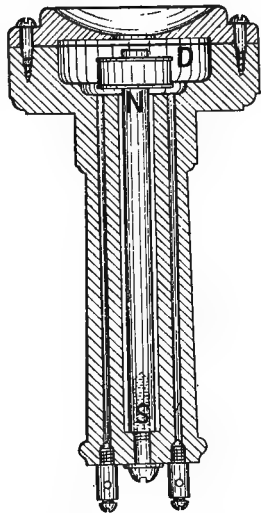
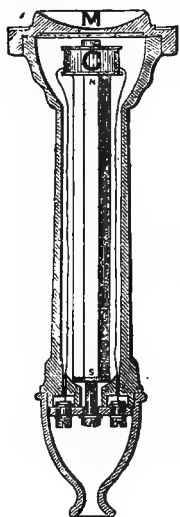

Fig. 5. $\frac{1}{2}$ full size.

A further development in construction is shown by fig. 6, in which the lighter and more handy case is made of ebonite and a cap is provided to protect the end of the flexible cord. The magnet is a hexagonal permanent bar magnet of the best steel, about $4\frac{1}{2}$ inches long and $\frac{1}{2}$ inch in diameter. Upon its N end, which is turned true, is placed a small boxwood bobbin C, wound with insulated



copper wire, generally to a resistance of about 40 ohms. The ends of this coil are connected to two terminals at the end of the case.

The vibrating plate, or diaphragm, which has a diameter of 2 inches in its free part and a thickness of from 9 to 10 thousandths of an inch, is of sheet iron, and is either tinned or coated with varnish to prevent oxidation. The ferrotype plate used by photographers is found to be most suitable for a diaphragm of the diameter given. The mouthpiece M screws on to the case as shown in the figure; and the vibrating plate, squeezed between it and the case, is thus kept in position.

The resultant effect of the iron disc on the magnetic field is probably to shift the pole nearer to the end of the magnet; the disc itself becomes, as it were, part of the pole. The coil of wire is permeated by lines of force, and any vibration or displacement of the disc vibrates or displaces these lines of force. The changes in the magnetic field in which is placed the coil fixed at the end of the magnet give rise to induced magneto-electric currents in the coil.

In order to get a clear idea of the *modus operandi* of the reproduction of sound by means of the Bell telephone, it is desirable to examine its various phases when used (1) as a transmitter and (2) as a receiver. The conditions for a complete circuit between two places S_1 and S_2 are shown in fig. 7. On speech being uttered before the mouthpiece of the magnetic telephone at S_1 , the sonorous vibrations of the air due to the voice transmit their energy to the diaphragm M , which follows, in all their variations of pitch, amplitude, and

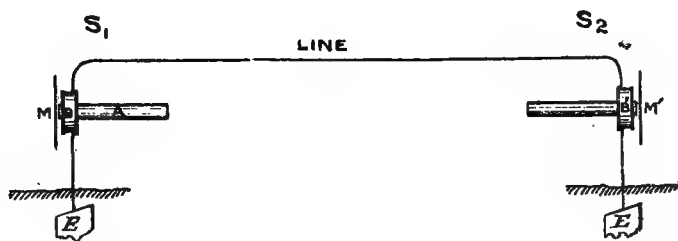

Fig. 7.

timbre, those of the air itself set into vibration by the voice. The movements of the diaphragm as it approaches or recedes from the neighbouring pole of the magnet, cause corresponding modifications in the distribution of the magnetic lines of force in the field passing through the coil. These variations in the lines of force give rise in the wire of the coil to induced currents of varied direction and strength, which are transmitted by the line wire to the coil of the receiver.

The telephone is, in fact, actually a generator of electricity—a generator so sensitive that it is absolutely controlled by the sonorous vibrations of the air, so that

they determine the strength and form of the periodic currents it generates, and make them follow all the varying and complicated undulations which characterise articulate sounds.

The periodic or undulatory currents developed in one telephone by the vibrations of the diaphragm M at S_1 are conveyed to the second telephone, placed at any distance away, which re-transforms them into sonorous vibrations. When these periodic currents pass through the coil B' of the receiving telephone, they increase the magnetisation of the bar if they traverse the coil in a direction favourable to magnetisation, and diminish it if they are of inverse direction; the diaphragm M' obeys these changes of magnetisation, approaches the coil when the magnetic force increases, withdraws from it by its own elasticity when the force diminishes, and by this undulatory action vibrates in unison with the diaphragm of the transmitter at S_1 , so reproducing the sonorous vibrations, although with perceptibly smaller displacements, and consequently with reduced loudness.

This explanation of the phenomena which occur in the Bell telephone acting as a receiver is, however, considered by some, if not as inexact, at least as insufficient. Instead of regarding the vibration of the diaphragm as due only to magnetic attractions and repulsions by the magnetised bar, there is an inclination on the part of French physicists to believe that the rapid magnetisations and demagnetisations in the bar produced by the induced currents give rise to molecular disturbances in the mass of the bar; that these disturbances are communicated to the diaphragm, and there cause oscillatory motions, which finally manifest themselves in sonorous vibrations.

On measuring the currents developed in a Bell telephone, they are considered much too feeble to account for the effects produced in the diaphragm of the receiver, if these effects are to be attributed to attractions pure and simple. This is simply a theoretical difficulty; but it is supported by Ader, who constructed telephones without a vibrating membrane, and even without a magnet, and obtained transmission of speech with magnets made from iron wire fixed to a small plate and placed in communication with a metallic mass; and also by the experiments of Antoine Bréguet, who replaced Bell's thin membrane by plates fifteen centimetres in thickness, clearly indicating that molecular effects and magnetic attractions combined together to reproduce the sounds of the transmitter. In short, the actions and reactions at play in the telephone are less simple than was thought at first, and the theory of the instrument is far from being finally settled.

In France the question has exercised the ingenuity of numerous experimenters. Du Moncel,² who studied it with great care, arrived at the conclusion that there exist several conditions which combine for the reproduction of speech:—

1. The molecular vibrations of the magnetic core and its armature, consequent upon their alternate magnetisation and demagnetisation under the influence of undulatory currents.

2. The true electro-magnetic attractions of the mass of the diaphragm.

3. The reciprocal action of the spirals of the magnetising coil.

² Du Moncel, "Le Téléphone," 4^{me} édition.

4. The mutual reaction between the coil and the magnetic bar.

5. The mechanical transmission of the vibrations of the electro-magnetic system by the various accessory parts constituting the telephonic apparatus.

Mercadier³ considers the diaphragm to be subject to two movements, molecular and molar. The former are independent of form, like the resonance of a wall; the latter are transversal, and act as a whole, like the skin of a drum. He replaced the iron diaphragm of the Bell telephone by a sheet of paper, cardboard, mica, glass, vulcanized indiarubber, zinc, aluminium, copper, etc, on which he sprinkled a small quantity of iron filings, and came to the conclusion that in the magnetic telephone, whether employed as transmitter or as receiver, the iron diaphragm never acts like a sonorous body vibrating in its entirety: it vibrates like a congregation of particles each gifted with independent movements.

There are, however, as Gerald points out, certain facts proved by practical telephony which cannot be explained by this or any other theory. How is it that multipolar telephones (p. 48)—that is, instruments in which the diaphragm is opposed to several magnetic poles—do not of necessity show any superiority over unipolar ones? (see, however, pp. 42 and 51.) If all the particles of the diaphragm are in motion, if each of them contributes its share towards the reproduction of articulate vibration of speech, there would be a direct gain in utilising all these movements, in employing all these molecules as modifiers of the magnetic field; in default of one rather large pole, the employment of several poles would seem

³ "La Lumière Electrique," 1886, p. 246.

to be indicated ; and yet we find that such is not the case. Further, why should several telephones, receiving the voice at the same time, and acting on the same line, not give a sensibly better result than a single one ?

The views of Du Moncel and Mercadier have not received general acceptance, and we are content to believe that the diaphragm of a Bell telephone, influenced by magnetic attractions and repulsions, acts as a simple sonorous body subject to harmonic displacements, and imparting these movements as sonorous vibrations to the surrounding air.

The following experiments will show the extreme sensitiveness of the magnetic telephone :—(a) By Dr. Werner Siemens,⁴ a Bell telephone, the pole of whose magnet was surrounded by 800 convolutions of copper wire of 1 mm. diameter and 110 ohms resistance, was placed in circuit with one Daniell cell. By means of a commutator contained in the circuit the current could be reversed 200 times per second ; and when the commutator was set into continuous motion, undulations were obtained which produced in the telephone a loud crackling noise. The primary wire of a small induction coil was then placed in the commutator circuit, whilst the telephone was in the circuit of the secondary coil, so that, when the commutator was set in motion, the currents induced in the secondary coil acted on the telephone. A loud noise was produced, even on inserting 50,000,000 ohms resistance, and this noise remained audible when the secondary coil was pushed back to the very end of the primary one, thus reducing the inductive action of the primary coil to a minimum, and placing it beyond the reach of measurement.

⁴ " Monatsberichte der Berliner Akademie für 1878."

(b) By W. H. Preece,⁵ who determined that a Bell receiver will respond to a current which may be expressed thus :— 6×10^{-13} ampère, or thus—'000,000,000,000,6 ampère; that is, six ten-thousand-millionths of a milliampère.

(c) By Pellatt,⁶ who has also expressed similar results in a different form. A condenser of one microfarad capacity was charged 160 times per second by connecting it with two points of a circuit, and discharged through a telephone. If K be the capacity, and v the difference of potential at the terminals, the expended energy for n charges and discharges is nKv^2 . If v be reduced to '0005 volt, a tone is still heard in the telephone, although the energy is so small that it could only produce one gramme-degree heat unit in 10,000 years. With this small quantity of heat, therefore, the telephone might be made to reproduce sounds during 10,000 years.

The great sensitiveness of the Bell telephone makes it one of the most beautiful illustrations that there is of the equilibrium and the unity of natural forces—an equilibrium so nicely balanced that in this case no change, however slight, can take place in one of the telephones without immediately producing a corresponding change in the other. This is the more remarkable when we consider the various transmutations of energy effected. The organs of speech produce in the first instance sonorous vibrations, which, impinging upon the diaphragm, give rise to oscillations which, in their turn, result in rapid changes of the field of the magnet, and consequently in the production of induced currents in the coil placed in that field. These induced

⁵ British Association, Manchester, 1887.

⁶ "Journal de Physique," 1881, p. 358.

currents, conveyed by the line-wire to the coil of the magnet in the receiving instrument, produce analogous changes of magnetisation in the magnet; and result, partly through attraction of the mass and partly through molecular action, in vibrations of the diaphragm of the receiver. The vibrating diaphragm imparts its motion to the surrounding air, and gives rise to sonorous vibrations which strike the tympanum of the ear. There are thus no less than eight distinct transmutations and transformations of energy, each of which is accompanied by a certain unavoidable loss of energy. Further losses, also, arise from inductive action of neighbouring wires, leaks through the supports of wires, electro-static and electro-magnetic induction, etc. It is, therefore, quite evident that the receiver can in no case emit sounds of the same intensity as those expressed before the transmitter; the wonder is that sonorous vibrations, which develop mechanical effects of a necessarily minute character, can be reproduced at all by the telephone through such great distances and after so many changes.

Another theoretical point of much practical interest has been examined experimentally by Mercadier. It is the question as to the proper relations which should exist between the several parts of a magnetic telephone. His experiments seem to indicate the following relations:—

1. That in a magnetic field of a given strength there is a certain thickness of diaphragm which will give a maximum effect. Generally, the stronger the field the thicker should be the diaphragm.

2. That the correct thickness of the diaphragm being known, there is a certain diameter which will give a maximum effect. Generally, the stronger the field the greater should be the diameter.

3. That the relative positions of coils, magnets, and diaphragms should be determined by the consideration that the greater the number of lines of force which traverse the coil at right angles to its plane, and the greater the variation in these caused by a movement of the diaphragm, the greater will be the effect.

It is to be observed that an essential feature of the receiving telephone is that the vibrating diaphragm shall be in a permanent magnetic field, but that the working efficiency of the telephone cannot be indefinitely increased by increasing the intensity of this field. Although the magnetism is generally obtained from a magnetic core within the coil, there is no actual necessity that this should be so—it may, for instance, be secured by a permanent magnet suitably placed outside the telephone, or by means of a current circulating in the coil itself (or in a separate coil) placed upon a soft iron core.

The following explanation of the need for the permanent magnetic field is suggested by Mr. Oliver Heaviside.⁷

The stress between the iron disc and the poles of the electro-magnet varies as the square of the intensity of magnetic force between them. Now, if the diaphragm is to be forced to execute vibrations by varying the stress upon it, the variations must be made as great as possible in order that the greatest amplitude of vibration (and consequently the greatest intensity of sound) may be obtained.

Suppose, then, that the intensity of the permanent magnetic field be represented by H , so that there is a steady stress proportional to H^2 , which will be varied by means of the undulatory currents in the coils. Let

⁷ *Electrician*, vol. xviii., p. 302.

h be the amplitude of the undulations of magnetic force resulting from the undulatory currents, so that the range of variation is $2h$. This is itself quite independent of H , but the stress varies from being proportional to $(H-h)^2$ to $(H+h)^2$, that is, the range of variation of stress is $4Hh$, apart from any constant; or the variation is proportional to the *product* of the permanent into the undulatory magnetic force.

Now ordinarily H is many times greater than h ; but suppose that H be reduced or h increased until they are equal. The magnetic force will then vary from 0 to $2h$, and the stress from 0 to $(2h)^2$. Or, again, suppose the permanent field be abolished; then, while the magnetic force will vary from $-h$ to $+h$, the stress will vary from h^2 through zero to h^2 again. The diaphragm will thus be urged to execute double vibrations, as in any ordinary case of sending reversals through a non-polarised instrument. Of course these double vibrations would not be observable, but they would probably have a distinct effect in opposition to the clear reproduction of speech, and by using a strong magnetic field they become non-existent.

At first sight the squaring of the intensity to determine the proportional stress appears to indicate that an indefinitely strong field would secure the best results: but experience shows that this is not so; and the explanation of the fact is probably to be sought in the considerations, first, that the diaphragm loses its elasticity under strong attraction; and, secondly, that the variations produced by the undulatory currents cease to be appreciable when the permanent force is greatly in excess.

CHAPTER III.

EDISON'S TRANSMITTER AND HUGHES' MICROPHONE.

IT is quite clear that when we speak into a Bell transmitter only a small fraction of the energy of the sonorous vibrations of the voice can be converted into electric currents, and that these currents must be extremely weak. Edison applied himself to discover some means by which he could increase the strength of these currents. Elisha Gray had proposed to use the variation of resistance of a fine platinum wire attached to a diaphragm dipping into water, and hoped that the variation of extent of surface in contact would so vary the strength of current as to reproduce sonorous vibrations ; but there is no record of this experiment having been tried. Edison in 1877 conceived the idea of utilising the fact that the resistance of carbon varies under pressure. He had independently discovered this peculiarity of carbon, although it had been previously described by Du Moncel in the following words : " The pressure exercised between two conducting bodies abutting against each other has a considerable influence upon the strength of the current," and also : " The increase of current strength with the pressure exercised at the point of contact is the greater the higher the resistance of the

conductors, the less hard they are, and cleaner their surface." Du Moncel's claim has been acknowledged by Lord Kelvin (Sir W. Thomson) thus: "It is true that the physical principle applied by Edison in his carbon telephone and by Hughes in his microphone is the same; but it is also the same as that employed by Clérac, of the French Telegraph Office, in his variable resistance tube, which he had lent to Mr. Hughes and others, in 1866, for some important practical applications. This apparatus is, however, entirely dependent upon a fact enounced a long time ago by Du Moncel—that the increase of pressure between two conductors in contact produces a diminution in their electrical resistance."

*Edison's Carbon Transmitter.*¹

The first carbon transmitter was constructed by Edison in 1877. After passing through various stages the instrument finally received the form represented in fig. 8. It consists of an ebonite mouthpiece M, a vibrating plate D, and a disc of prepared carbon C, of the size of a shilling, withdrawn from or brought near to the vibrating plate by means of a screw V, at the back part of the transmitter. A small platinum plate B, with a rounded ivory button, is placed on the upper surface of the carbon disc. The vibrations of the diaphragm are communicated to the carbon by the small platinum plate. According to the inventor, the variations of pressure produced by these vibrations cause a variation of electrical resistance in the carbon. The circuit through the transmitter is from terminal A, by way of the spring s, which bears on the periphery of the

¹ British Patent Specification 2,909 (July 30, 1877). Disclaimer, August 17, 1882.

insulated ring *r*, through the ring to the platinum plate B, thence through the carbon disc C, and to the second terminal E, which is connected to the case itself.

The function of a carbon transmitter is restricted to the production of variations of electrical resistance in the circuit; these variations immediately occasion proportionate variations, in an inverse sense, in the strength of the primary current. For a given vibration, the change in the resistance of the circuit will have a given value, which we will assume, for argument's sake, to be 1 ohm. If the entire circuit has a small resistance—10 ohms for instance—the variation of 1 ohm produced

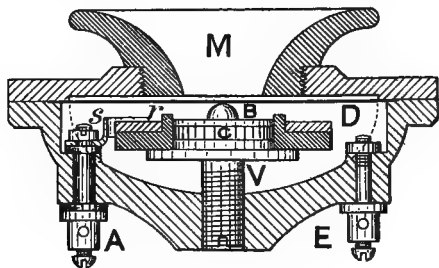

Fig. 8. $\frac{3}{4}$ full size.

in the transmitter will vary the current strength by $\frac{1}{10}$ of its total value, and consequently the receiver, which acts under the influence of these variations of current, will vibrate with great energy, and produce a certain sound. If, on the contrary, the total resistance of the circuit is large—1,000 ohms for instance—the variations of current will be proportionately small—only $\frac{1}{1000}$ of the total current strength in the assumed instance—so that the receiver will vibrate with less energy and the sound be much less. To obtain, therefore, an equally powerful effect in this case as in the

other, it would be necessary to increase the number of battery cells to an extent that would be quite out of the question in practice.

Edison got over this difficulty by employing an arrangement applied already in 1874 by Elisha Gray to his musical telephone. Instead of causing the current passing through the transmitter to traverse the line, Edison simply passed it through the primary wire of an induction coil. One of the extremities of the secondary wire is then connected direct to earth, while the other is connected to one end of the line the other end of which is connected to the receiver and so to earth. The transmitter now acts only in connection with a small resistance, represented by the battery, the transmitter itself, and the primary wire, and consequently the variations of resistance of the transmitter have a considerable relative magnitude. These variations of resistance produce corresponding variations of current strength in the primary wire, which in the secondary wire are transformed by induction into currents of like proportion but high electro-motive force according to the number of turns of the wire (p. 12). These high-tension currents may be utilised for transmission through high resistance, and hence it becomes possible to telephone to considerable distances with an initial low electro-motive force. The action of the apparatus is as follows: On speaking before the mouthpiece M (fig. 8), the diaphragm vibrates, and these vibrations produce through the intermediary of the ivory stud and the plate B, variations of pressure in the carbon disc C. The resistance of the carbon disc is thus varied exactly in accordance with the number and amplitude of the vibrations of the diaphragm, and these variations produce

corresponding variations of strength of the battery current flowing through the primary wire of the induction coil. This current therefore becomes undulatory, and consequently induces currents in the secondary wire which pass to the line, to the further end of which is connected the receiver (an ordinary Bell telephone). The effect produced in the receiver is, of course, the same as in the case of a Bell telephone acting as transmitter, which has been already described (pp. 21 and 22). The performance of this carbon transmitter was, however, by no means satisfactory, and it is very doubtful if Edison's theory of its action is accurate.

*Hughes' Microphone.*²

In May, 1878, Professor Hughes read a paper before the Royal Society, in which he introduced an instrument

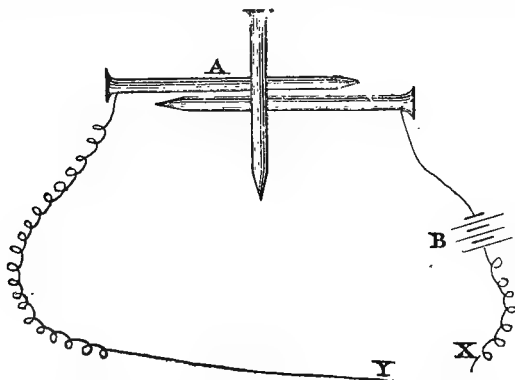

Fig. 9.

whose action depended upon the variation in resistance of a loose contact. This instrument its inventor called the *microphone*, from its supposed power to perform in acoustics with regard to minute sounds, a similar part

² Proceedings of the Royal Society, 1878.

to that performed in optics by the microscope in regard to minute objects. It should be observed, however, that there is nothing to prove an actual amplification of the sounds themselves; on the contrary, it seems more probable that it is an effect rather of transformation of molecular movements into sonorous vibrations than of actual amplification of the sounds.

Amongst the earliest forms which Professor Hughes gave to this instrument is that shown in fig. 9. He took two French nails, laid them side by side, not

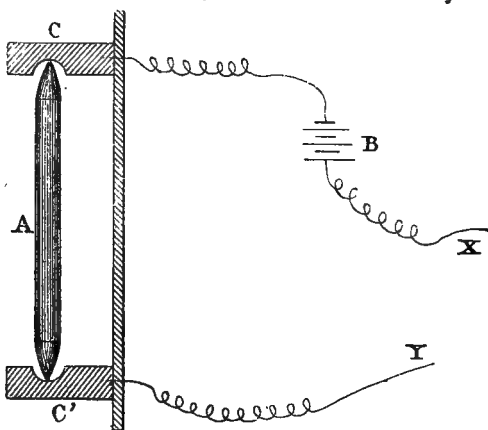

Fig. 10.

touching each other, connected wires to them, and, by laying between or across them a third and similar nail, he was able to reproduce almost perfectly in a telephone receiver fixed between X and Y the ticking of a clock, and he even got indications of the sound or tone of the voice. The apparatus, in fact, constitutes a real telephonic transmitter.

The effect produced is better still with carbon pencils, and the apparatus employing carbon, which has, with

a few modifications, remained *the* microphone *par excellence*, is represented in figs. 10 and 11. It consists of a small pencil of gas carbon A, terminating in a point at each end; these two ends rest lightly within two small circular holes in two pieces of carbon C, C', so that the carbon pencil takes up a vertical position between them; C and C' are fixed to a thin

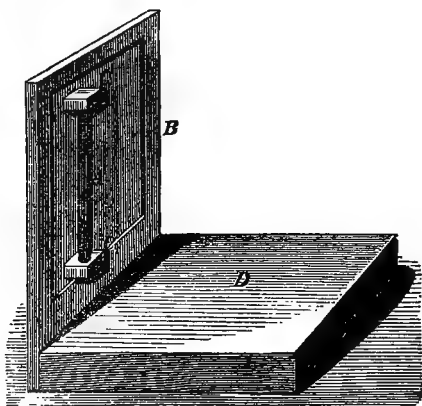

Fig. 11.

sounding-board, which is fitted in a vertical frame B on a solid block D (fig. 11.) The pieces C and C' are connected through the battery by the wires X and Y to the receiver.

The instrument, rough as it looks, is of surprising delicacy. It converts into sonorous vibrations not only musical sounds and words, but the slightest oscillations, and even an imperceptible rustling. The slightest touch, the least friction against the block, is sufficient to produce a grinding noise in the telephone. The point of a small brush rubbing against the block, the fall of a small cotton ball, produce a perfect uproar in the receiver;

the movement of a fly or any other insect walking upon the diaphragm may be distinctly heard.

The difference between Edison's carbon transmitter and the microphone in its simple form as constructed by Hughes is very slight; but the Edison form has disappeared, and, in the same way as all magnetic telephones are more or less imitations or modifications of the original Bell instrument, so all carbon transmitters are now modifications of Hughes' ingenious apparatus. The number of these imitations is legion; many of them are modifications without much practical value. In succeeding chapters will be described some of those modifications which either represent real improvements and have given satisfactory results in practice, or which present some special features in construction.

The true action of the microphone or carbon-transmitter is very little understood, although, as in the case of the magneto-telephone, it has been much discussed. It introduces into a closed electric circuit through which a current is flowing a resistance which, by varying under the action of sonorous vibrations, causes the current to undulate in a way exactly analogous to the varying sound waves. This effect was at one time generally assumed to be due solely to a greater or less intimacy of electrical contact between two semi-conducting surfaces abutting upon each other; but there is now very little doubt that it is at least partly due to the effects of heat generated by the passage of electricity between two points in imperfect contact, whose relative distance is variable. Carbon, according to Shelford Bidwell, is the best material for the purpose; first, because it is inoxidible and infusible; secondly, because it is a poor conductor; and, thirdly, because it has the

remarkable property of having its resistance lowered when it is heated—the reverse of metals.

Attempts have been made to apply mathematical analysis to the determination of the best form and arrangement of microphones, but, so far, without success. The fact is, that the conditions due to heat in the microphone, and to self-induction in the induction coil, are very complicated, and are not yet sufficiently understood to bring the phenomena they produce within the region of mathematical analysis.

Experiments made by Shelford Bidwell³ indicate that the diminution of resistance of a microphonic contact is, under ordinary conditions, due not only to an increase of pressure, but also to the resulting increase of current, which amplifies the effect independently of the actual diminution of resistance of the point of contact. Further, it has been suggested by Stroh⁴ that the current induces a repellant action at the points of contact, so that the variations of resistance should be attributed to variations of thickness of the thin layer of air intervening between the carbons.

Hughes explained the variation of resistance by a variation of the *amount* of contact—that is to say, that in consequence of the change of position of the loose contact produced by the sonorous vibrations, a larger or smaller number of molecules take part in the transmission of current.

This by no means excludes the heat theory. It is at least conceivable that heat may assist the action of the sonorous vibrations. Hughes himself favours the idea of the existence of minute electric arcs at the points

³ "La Lumière Electrique," 1883.

⁴ "Telegraphic Journal," 1883, vol. xii., p. 221.

of contact. Indeed, there are many phenomena, such as hissing and humming, that are clearly due to what is known as the Trevelyan effect, that is, the motion set up by the expansion and contraction of bodies which are subjected to variations in temperature. This at least tends to favour the heat hypothesis, as does also the fact that with continuous use some transmitters become sensibly warm.

CHAPTER IV.

TELEPHONE RECEIVERS.

THE instruments which will be described in this chapter are all more or less merely modifications of the original Bell telephone. It is impossible to deal with all the forms that the instrument has taken, or even with all that are in actual use ; but an effort will be made to secure that instruments typical of most of the distinctive ideas either of form or magnetic construction shall be represented, in order that a clear conception of the directions taken by different workers may be obtained. It will be understood that some of these types are of merely historical interest.

*Gower's Receiver.*¹

One of the first successful modifications of the Bell telephone was that made by Gower in 1879.

The main difference between this instrument and Bell's consists in the form of the magnet, which, as will be seen by referring to fig. 12, has a semi-circular shape. Each pole of the powerful horseshoe magnet N O S is fitted with a small soft-iron-pole-picce, upon which a coil is fixed. Gower, appreciating the

British Patent Specification 315 (January 25, 1879).

desirability of the magnetic action being directed as closely as possible at the centre of the diaphragm, made the pole-pieces thin and long, and fitted coils to correspond, so that both poles of the magnet were brought very nearly together.

The whole was at first enclosed in a flat brass case,

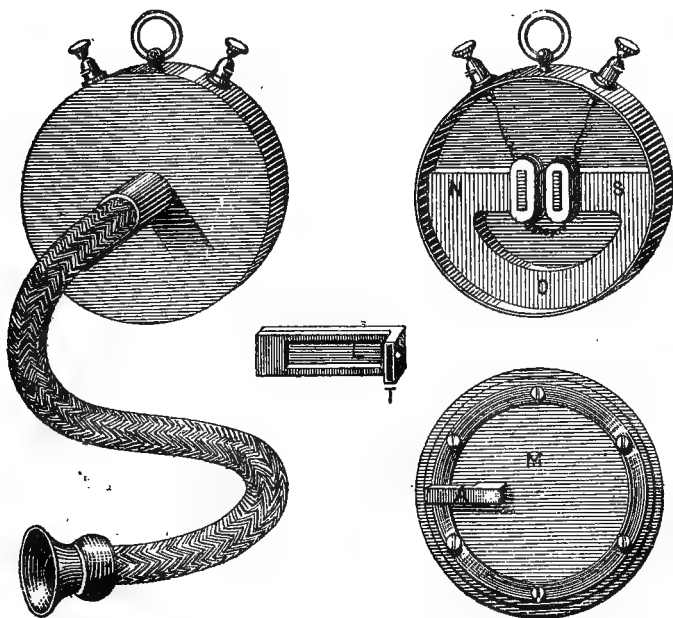

Fig. 12.

whose cover carried the diaphragm *M*, the thickness of which is slightly greater than that of the Bell.

Gower's idea at first was to make the magnetic telephone complete in itself—to act as both transmitter and receiver—and the figure illustrates his complete instrument.

Instead of the ordinary flexible wire permitting the

telephone itself to be applied to the mouth or ear, Gower fixed the magnetic telephone, and fitted it with a flexible tube like those used on speaking-tubes.

To call attention, he used a reed call, represented separately in the figure to a larger scale (half full size). It consists of a tube A bent at right angles, fastened to the diaphragm M. One end, T, of the tube faces the diaphragm, whilst the other opens into the telephone case; the tube contains a vibrating reed L. By blowing into the acoustic tube, the reed vibrates, and its vibrations are communicated to the diaphragm. These intense vibrations induce powerful magneto currents, which give rise in the receiver to corresponding vibrations, and thus create a considerable noise. By adding a large resonant ear-trumpet to the apparatus the sound can be heard at a considerable distance. The fitting to the diaphragm of the tube A in no way disturbs the clearness of transmission, while as a call it is very efficient.

*Siemens' Receiver.*²

This instrument, which is very extensively used in Germany, is represented in figs. 13 and 14. It is one of the earliest of the bi-polar telephones which have now come into such general use.

On the horseshoe magnet N S are fitted two soft-iron pole-pieces, which carry the small oblong soft-iron cores *n s*, fitted with coils *e* of fine insulated copper wire.

The horseshoe magnet is held in position by means of a screw, which passes through a wooden block *f* fixed to the iron disc *a*, and through a brass plug in the centre of the wooden block. When, therefore, the screw is

² Grawinkel, "Telephonie und Mikrophonie," p. 73.

turned, the magnet is drawn back or advanced, so that the screw serves as an adjustment. Small pieces of hard wood are clamped at *cc* on each side of the two extremities of the magnet, and serve for the reception of the wires *d*, which are connected to the convolutions of the two coils *e*. The wires *d* terminate at two screws at either

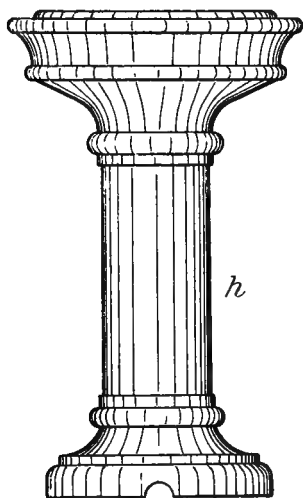

Fig. 13. $\frac{1}{2}$ full size.

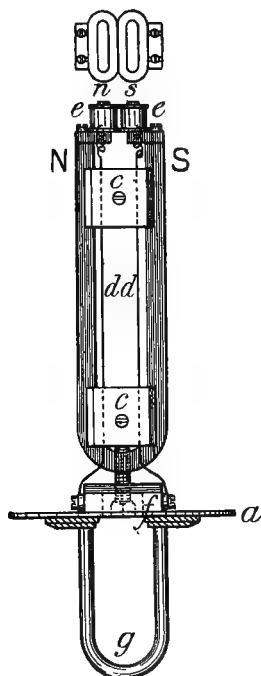

Fig. 14. $\frac{1}{2}$ full size.

side of the block *f*, and the line wires are connected to these screws. An iron stirrup *g* for the suspension of the instrument is fastened to the plate *a*.

The whole is placed in a cylindrical tube of sheet iron *h* (fig. 13), so that *a* forms an end plate.

In place of the reed-call with which this instrument was originally provided a magneto "siren-call" has recently been devised. This is shown in fig. 15. Between the poles of the permanent magnet and beneath the coils is fitted a small solid cylinder consisting of two segments of soft-iron separated by a central brass-piece as shown to the right in the figure.

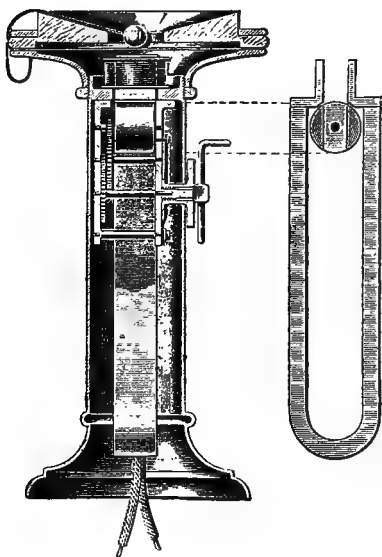

Fig. 15.

This cylinder can be rapidly rotated by means of a small crank-handle with which it is geared through a train of wheels. Now, when one of the soft-iron segments is made to take up its position across the poles of the permanent magnet the magnetic field will be diverted from the coils on the pole pieces; and this change will result in an induced magneto current in the coils. The replacement of the armatures to the position

shown will induce another current; and, as such changes can be effected with considerable rapidity by means of the crank-handle and its gearing, alternating currents may thereby be induced which will cause the diaphragms of all receivers in the circuit to emit a siren-like sound, which is ordinarily sufficient to act as a call. If a louder sound is required the small bullet-

shown in the figure is left resting upon the diaphragm and acts to intensify the sound emitted.

The armature, if left to itself, would take up a position across the poles, and weaken the magnetic field through the diaphragm. In order to prevent this, when the telephone is used for conversation it is necessary that the armature be always brought into its neutral position, and locked there. This is done by a special spring-catch, dropping a pin into a pin-hole, which arrests the armature in the proper position.

Fig. 16 shows another form of Siemens' telephone, which is designed for use in combination with microphone transmitters. The side-magnet and the large ear-piece tend to make this a very handy instrument, and in the later pattern with aluminium fittings, it is extremely neat and light. The figure is about $\frac{1}{4}$ full size.

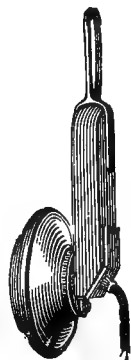

Fig. 16.

*Ader's Receiver.*³

This telephonic receiver is extensively used in France, in Belgium, and in Austria. It consists, as will be seen from fig. 17, of a circular magnet A, which at the same time serves as handle to the instrument. On the cores B, fixed to the two magnet poles, two coils are wound, an arrangement similar to that in the preceding apparatus. Ader, however, has added a soft-iron ring X, placed before the vibrating plate M, to which he has given the name of "over-exciter" (sur-exciteur). The object of this iron ring is to excite

³ "Sieur, Etude sur la Téléphonie."

more strongly, by means of magnetic induction, the opposite magnet poles. The theory of this magnetic reaction was first stated by Du Moncel in 1878. He found that the more the mass of the armature of a magnet approaches in magnitude that of the magnet itself, the more powerful is their reciprocal induction, until, when the masses are equal, it reaches a maximum. It is clearly not feasible to increase the mass of the telephone diaphragm to such an extent, as that would inevitably destroy its vibrating quality, but by placing the diaphragm between the magnet and a

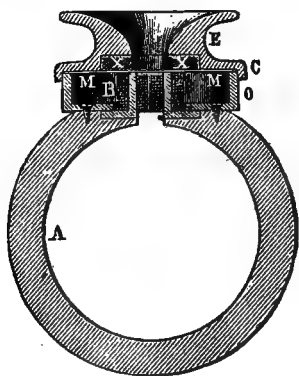

Fig. 17.

massive fixed armature, a similar advantage is secured. This is what Ader does. By fixing the iron ring *x* in front of the diaphragm, the lines of force are concentrated forward through the plane of the diaphragm instead of being directed back as in the case of the ordinary Bell receiver. The variations in the magnetisation of the magnet produced by the induced

currents have consequently a maximum effect on the vibrating plate, whose centre is placed in the strongest possible magnetic field perpendicularly to the lines of force. The telephone thus becomes more powerful and more sensitive to the extremely delicate inflections of the undulations constituting the timbre of the human voice. Ader's receiver is certainly one of the most sensitive at present in use.

The theory of this receiver is well illustrated by an

instrument devised for the purpose by the inventor. In front of an adjustable permanent magnet is placed a flexible iron strip, the position of the magnet being so adjusted that the strip is not deflected. If now, a mass of iron be made to approach the magnet on the opposite side of the strip, the increase in the strength of the field is immediately shown in the attraction of the strip by the magnet.

*D'Arsonval's Receiver.**

The inventor of this instrument put forward the theory that in telephones with two poles and two coils, such as have been described, the only really useful part of each coil is that situated between the two poles; the part of the wire which is outside being almost completely lost for purposes of induction, and simply introducing a useless resistance, as all the lines of force of the magnet are concentrated in the inter-polar space.

In order to subject the whole of the wire to induction, D'Arsonval constructed an annular magnetic field, as in the Nicklés electro-magnets, by taking one of the poles of the magnet as centre,

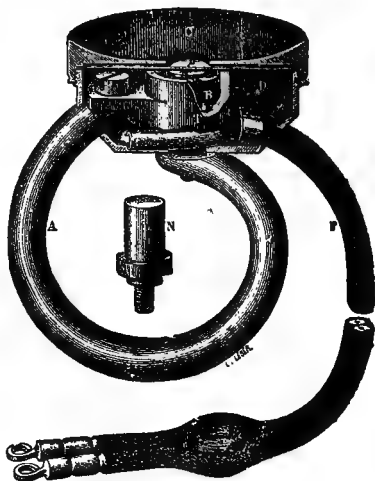

Fig. 18.

* "La Lumière Electrique," 1882, p. 150.

while the other pole surrounds it in the form of a ring. The coil being then fitted on the central pole, all the convolutions of the wire are within the strongest possible magnetic field, and are consequently subjected to maximum induction.

The permanent magnet therefore consists of a spiral part A (fig. 18), one extremity of which carries the central pole (represented separately at N), on which is placed the coil B; while the other extremity carries an iron cylinder T, completely surrounding the coil, so that it is, as it were, enclosed in a circular magnetic field of great intensity.

The case D, which carries the iron diaphragm, is fixed in the most simple and most solid fashion, without requiring any screws, by being clamped between the magnet and the central core.

The connections to the conductors of the cord F are made inside the case, so that the need for outside terminals, which are more or less liable to be interfered with, is obviated.

In this form the complete instrument, which weighs less than one pound, gives excellent results.

*Goloubitzky's Receiver.*⁵

Starting from the fact that several telephones placed at the receiving station can simultaneously reproduce speech without any sensible loss of sound in each of them, Goloubitzky thought that, by combining these several telephones into one, an apparatus might be obtained which would produce more intense sounds.⁶ A further step in the same direction led to the con-

⁵ "La Lumière Electrique," 1882, p. 503.

⁶ The late G. W. Phelps had put forward the same idea in America in 1878.

clusion that several magnets acting at the same time on the same diaphragm would effect the same purpose, provided that the vibrations produced were concordant. These considerations resulted in the construction of the telephone shown in fig. 19. The poles of two horse-shoe magnets crossing each other at right angles are placed opposite the diaphragm, in the annular region

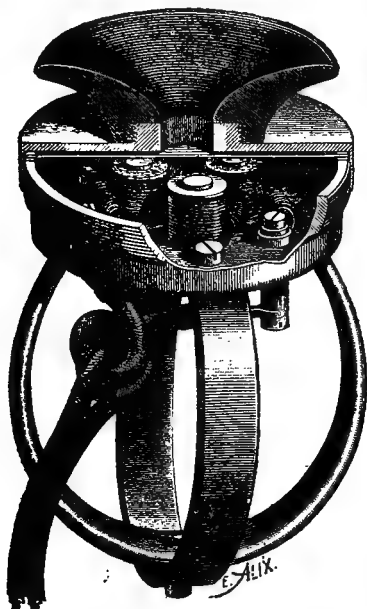

Fig. 19.

corresponding to the centres of vibration; the four poles of the two magnets form the four angles of a perfect square, two pairs of similar poles being necessarily side by side. Care is taken in manufacture to ensure that the diaphragm is just clear of every pole—a hollow sound produced by tapping on the diaphragm through the

opening of the mouthpiece indicates that this is so. The electro-magnet coils are first connected so as to correspond to the two different poles of the same magnet, and the two pairs of coils are then joined in series.

*Neumayer's Receiver.*⁷

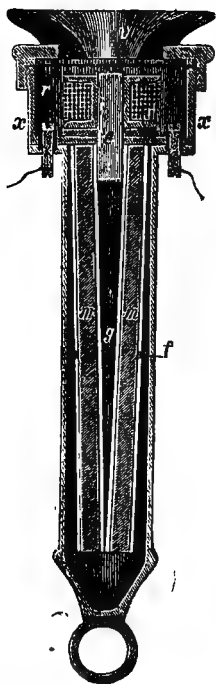

Fig. 20.

This instrument has been used for the Bavarian telephonic service, and is a very successful modification of the original Bell. The magnet *m m* (fig. 20) consists of five cylindrical rods of best hardened steel. The pole opposed to the diaphragm is formed in the following way. Acting upon the recognised principle adopted in the formation of the cores of induction coils, Neumayer fills a thin brass cylinder with pieces of very fine iron wire (such as is used for wiring flowers), 3 centimetres in length, and solders them in. The coil is fitted upon the upper part of the cylinder, which is fixed firmly in the centre of the brass case *x*. Around the lower end of the core *e* the magnets are grouped and fixed in position by a brass ring which surrounds them at *f*.

The magnets are enclosed in a wooden case which is fastened to the bottom of *x* and terminates in a brass ring. The object of fixing the core *e* in the case *x* is in order that the variations of distance between the pole and

⁷ "Electrotechnische Zeitschrift," 1884, p. 339.

the membrane arising from variations of temperature may be as small as possible, and thus to dispense with a special regulation of the receiver, as the distance of the magnet from the membrane is thus rendered independent of the variations in length of the magnets. The diaphragm is .3 mm. thick, and rests upon the upper rim of the metal case. It is kept in position in the usual manner by the cap carrying the ebonite mouthpiece *v*, which is screwed on to the top of the case. The coil is wound with copper wire of .11 mm. diameter to a resistance of about 100 ohms.

Double-pole Bell Receiver.

As already stated (p. 42), the firm of Siemens Bros. was the first to revert to Bell's original idea of bringing both poles of the inducing magnet to act upon the diaphragm. This is now coming to be generally recognised as the best plan, and nearly all makers have adopted it. The general plan upon which the most approved double-pole receivers are now made was introduced by the Western Electric Company, and fig. 21 shows one of the developments from their pattern. The case is usually of thin metal with an ebonite sleeve over the cylindrical part; but there are advantages in an ebonite case as shown, from the fact that the connections from the coil are sometimes found to be in contact with the case, and that the exposed nickelled brass-work does not stand wear so well as ebonite. On the other hand, it must be admitted that rough usage or accident are very apt to shatter the light ebonite case. It will be seen that dished washers at the curved end of the magnet provide for slight adjustment. The terminals shown are those adopted by the Post Office to obviate

the need of special ends to the connecting cords. The tinsel conductor is clamped beneath the head of a screw

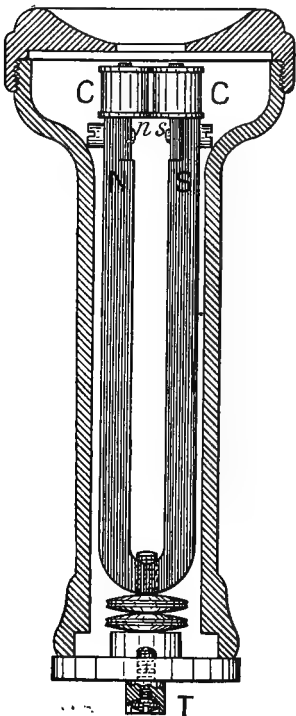

Fig. 21. $\frac{2}{3}$ full size.

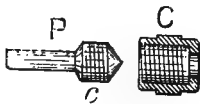

Fig. 22. Full size.

which exactly fills a recess in the top of the terminal pillar. A carefully finished gap in the periphery of the recess permits the conductor to pass without danger of damage.

A good form of "tag" for the ends of conductors that are to be connected to "French" terminals is shown full size in fig. 22. The enlarged end *c* of the pin *P* which is fitted in the terminal is threaded and fitted with a cap *C*, through the centre hole of which the cord conductor is brought and then spread out to be clamped by the screwing-up of the cap. This principle would itself produce an excessively neat terminal by screw-threading the upper part of the actual terminal as at *c*, and fitting it with a cap. A brass washer would be needed in the cap in

such a case. The tag is made by the General Electric Company.

“ Watch ” Receivers.

Various forms of small flat circular receivers are now in general use, and although for the most part they are not the best form for efficiency, they are convenient and good for short line working.

One of these is shown by fig. 23. This is the pattern used with the De Jongh instrument. The magnet is a ring with projections, which are curved round and form poles behind the opening in the ring. Thus the coils attached to the poles project through the hole in the ring.

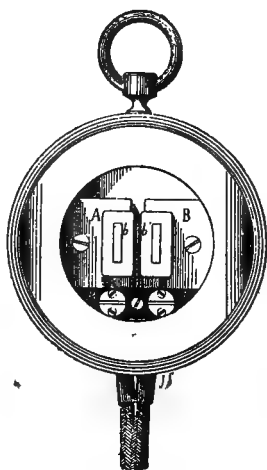

Fig. 23.

*Collier's Receiver.*⁸

This receiver, one form of which is shown in fig. 24, possesses the special feature of interest that a distinct claim

is made for it that it is actually more efficient than any other receiver yet made ; and although some of the statements put forward must be accepted with considerable reserve, there is no reason to doubt that it is a very good instrument. The arrangement of the parts is as follows :—Through the main body of the case is fitted the coil C, the core of which is of special construction ; it is formed either of soft-iron wires, as in the case of an induction coil, or (as shown in fig. 25) of several sections of soft-iron magnetically insulated. This construction is adopted to prevent the formation of Foucault currents

⁸ British Patent Specification, 13,756. 1889.

in the core. Close to *each* end of the core is fitted a diaphragm D; clamped in position by a screwed cap, through the centre of each of which is screwed a soft-iron "pole-piece," which is made to very closely

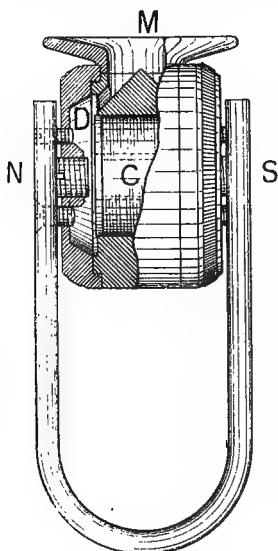

Fig. 24. $\frac{2}{3}$ full size.



Fig. 25.

approach the diaphragm, while it slightly projects outside the cap. Screwed to the caps, with its poles clamping the soft-iron pole-pieces is the strong permanent magnet N S. The general effect is, therefore, to place the coil in a strong magnetic field, the lines of force of N S being concentrated through the core and the diaphragm. At the top of the case, as shown, or at the side, is fitted a mouth-piece M (or the case itself is suitably shaped), and air-communication with the spaces between the diaphragm and the coil is secured by means of a series of holes arranged in line with and around a conical formation of the case at the mouthpiece.

When wound to the same resistance (120 ohms) as the Western Electric double-pole receiver, experimental instruments have been found slightly superior to selected double-pole receivers, and about 5 per cent. better than the average receiver that has not been specially

adjusted. It is usual, however, to wind the Collier receiver much higher (about 300 ohms), and we are not aware of any comparative tests having been made with other receivers wound to that resistance.

"Head-gear" Telephones.

It is often desirable that the user of the telephone shall have both hands disengaged ; but the receivers



Fig. 26.



Fig. 27.

hitherto described necessitate the use of one or both hands for holding them. The special requirement

arises more especially in connection with the manipulation of telephone-exchange switches; but there are also other circumstances in which the holding of a receiver to the ear becomes inconvenient and tiresome: for instance, where a long message from or for a news agency has to be transcribed by dictation from a distant office. To meet such requirements "head-gear" telephones are generally used. Two forms of these instruments are



Fig. 28.

shown in figs. 26 and 27. In the former the receiver, of the "watch" pattern, is fixed at the end of a single flat spring, at the other end of which is a pad. The spring merely fits over the top of the wearer's head. The whole weight with Western electric aluminium cased receivers is only 9 oz., including connecting cords. In fig. 27 there are two springs, each of which is slotted, so that they can be adjusted and clamped in any required position. This appears to be the better form in cases where the wearer requires to bend over a desk or to move about while the telephone is in position. Two receivers are sometimes used in this case, and fig. 28 illustrates two receivers in connection with a very comfortable form of "head gear," made by Messrs. Siemens Bros. It will be seen that the instrument is fixed by means of a head-strap, and that the position of the receivers is adjustable.

*Mercadier's Bi-telephone.*⁹

Mercadier's researches on the theory of the telephone led him to the design of very small receivers, which give very excellent results. His receivers weigh only about $1\frac{3}{4}$ oz., as compared with the $9\frac{1}{2}$ ozs. of the ebonite-cased double-pole Bell receiver described on p. 51 (fig. 21). A full-sized section of the receiver is shown in fig. 29. The electro-magnet coils are mounted upon a laminated annular magnet M by means of threaded ends of the cores,

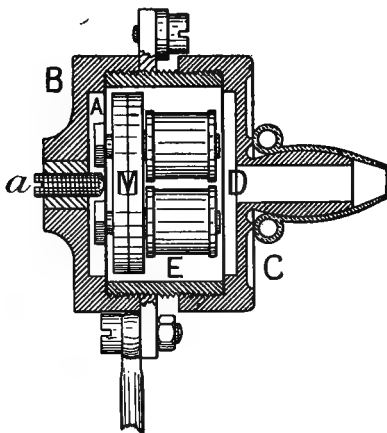

Fig. 29. Full size.

which project through the magnet and through a thin iron disc A, and are fixed by nuts on the other side. This disc is clamped between the ebonite back B and the threaded ebonite tube E. Between the other end of this tube and the ebonite cap C, which is shaped with an ear-piece, is clamped another disc D, which serves as a diaphragm. The adjustment of the distance between

⁹ "La Lumière Electrique," 1891, p. 37.

the poles and the diaphragm *D* is effected through the screw *a*, which is fitted in a brass bushing in the back *B*, and the inner end of which is screwed with more or less force against the disc *A*, upon which the electro-magnet is fitted.

The complete instrument (fig. 30), consisting of two receivers and their attachments, weighs only just over $4\frac{1}{2}$ ozs. The steel wire *v* by which the receivers *T T* are connected serves as a spring to press the ear-pieces *t* into the ears, and it may be easily adjusted to give any desired pressure. As it is objectionable to have several people

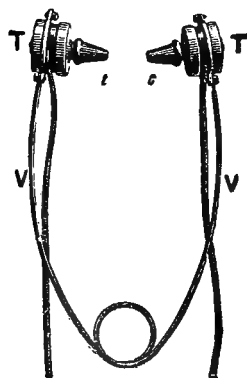

Fig. 30.

inserting the ear-pieces, separate rubber tubes (shown in section fitted over the tubular projection on *C* in fig. 29) are provided, which can be readily changed so that each user may have a separate pair. There is no doubt that the bi-telephone possesses distinct advantages, but the reasonable prejudice against the common use of an instrument which needs to be inserted in the

ears will probably prove a very serious obstacle to its general introduction.

Adjusting Clamps for Receivers.

In many forms of telephone receivers the practice is to adjust the position of the diaphragm by means of rings of thin metal or of paper, clamped between the diaphragm and the body of the instrument. These separate rings are naturally liable to get lost or broken

if the top is removed, and in any case do not appear a very satisfactory mechanical device. Messrs. Mix & Genest have consequently introduced a special clamp, which is illustrated in connection with a watch-receiver case by fig. 31. The diaphragm itself, *D*, is clamped firmly in the cover by means of the ring *R*, which is threaded on its periphery to screw into the cover. The cover can be screwed into position in the usual way, and when in its proper place as to adjustment can be rigidly fixed there by means of the clamping screw *C*. This clamping screw passes through the case into the brass piece *A*, from which a stout pin *a* passes through a

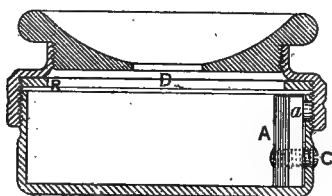

Fig. 31. $\frac{3}{4}$ full size.

hole in the case, and is threaded on its end to correspond with the screw-thread for the cover. The pin *a* is, however, rather longer than the case is thick; so that when, by the screwing-up of *C*, the piece *A* is drawn towards the rim of the case, the end of *a* firmly presses against the rim of the cover, and so effectually prevents it from being moved. This serves, therefore, not only as an adjustment, but also as a means of preventing unauthorised persons from tampering with the instrument, because the case cannot be opened except with the aid of a screw-driver.

CHAPTER V.

CARBON TRANSMITTERS.

THE original carbon transmitter of Edison is represented in its numberless successors in scarcely more than the fact of the use of carbon. Ceaseless efforts have been made by some of the most able of investigators to discover some material other than carbon that was equally efficient—efforts that, if they had been crowned with success during the continuance of the monopoly of the use of carbon, would have ensured a handsome fortune. Hitherto nothing has been found that even approaches carbon in efficiency for microphonic purposes, and now that the monopoly has lapsed the incentive to investigation is considerably reduced.

The principle adopted in connection with magnetic receivers will be followed also in this chapter—namely, a selection will be made of some typical forms of transmitters which will embrace some which are principally of historical interest, some which illustrate a more or less special principle, and others (and these the greater number) which are useful forms for present-day purposes.

Crossley's Transmitter.¹

The diaphragm of Crossley's apparatus (figs. 32 and 33) is a very thin deal board D, having at the corners small cork pads L, which are glued to a sloping board F H, in the centre of which is fitted a mouthpiece E.

Below the diaphragm (fig. 33) are fastened four carbon blocks B, B', B'', B''', between which four carbon cylinders, or pencils C, C', C'', C''' are arranged.

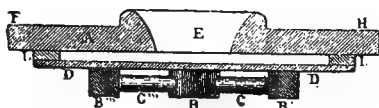

Fig. 32.

Fig. 33 represents the arrangement of the pencils between the blocks. It will be seen that the ends of the carbon pencils, which are smaller in diameter than the central part, fit loosely in holes drilled in the blocks. This was the first transmitter in which this

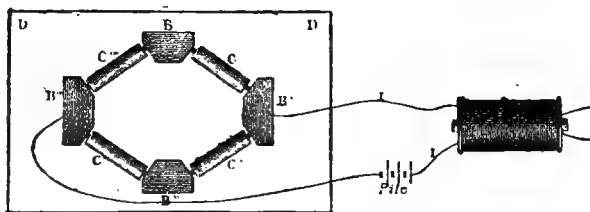

Fig. 33.

form of pencil was adopted, although, as already explained (p.35), Prof. Hughes' original microphone was essentially the same. Indeed, in his paper read before the Physical Society on the 8th June, 1878, Hughes

¹ British Patent Specification, 412. (February 1, 1879).

showed his appreciation of the desirability of using multiple contacts. He said, "a man's voice requires four surfaces of pine charcoal, six of willow, eight of box-wood, and *ten of gas carbon.*"

The current from the battery passes through the primary wire of the induction coil to the carbon block B', and thence by the two upper and the two lower pencils to the block B''' and back to the battery.

The vibration of the diaphragm, consequent on speech being directed towards it, causes variations of contact between the carbon cylinders and the carbon blocks, which produce variations of current strength in the primary wire of the induction coil. These variations of contact may be broadly explained in the following way: When the vibrating diaphragm makes a downward movement, the blocks B follow this movement, whilst the cylinders C, through inherent inertia, have a tendency to remain in place, and this establishes loose contacts between the cylinders and the blocks. When, subsequently, the diaphragm executes a reverse upward motion, the blocks following the diaphragm press more closely against the cylinders, which still have a tendency to descend—hence a better contact between the cylinders and the carbon blocks.

The Gower-Bell Transmitter.

This transmitter, which is shown in fig. 34, consists of eight carbon pencils supported between eight outside carbon blocks, C₁, C₂, C₃, C₄, and one central block, C, the whole being fixed beneath the diaphragm, which is a simple deal board about 9¼ in. × 5½ in. and 11 in. thick, fixed by screws beneath the top of the transmitter case, with soft rubber washers on either side, so that

the whole diaphragm may be as free as possible. The top of the case gives the diaphragm a slight slope (see fig. 102).

The carbon pencils, one of which is shown full size, are connected in two sets of four, by means of thin copper strips, *S S'*. The battery current, on its way to the primary wire of the induction coil, enters one set of pencils through four of the eccentric blocks, passes through the centre block, and leaves by the second group of pencils.

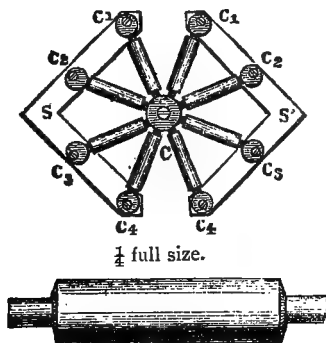

Fig. 34.

The diaphragm is protected by a teak board furnished with a porcelain mouthpiece, the object of which is to secure direct speaking towards the centre of the diaphragm, and to prevent the latter from being used as a desk. It, however, presents a disadvantage which occasionally necessitates its being abandoned—namely, the condensation of moisture upon the cold surface of the porcelain during use, which in cases where the instrument is continually used becomes very objectionable, and has even been known to cause a fault in the instrument.

The Gower transmitter is used very extensively by the British Post Office and others. For an indication of its efficiency see p. 106.

Ader's Transmitter.

The carbon cylinders are of the same form as in the preceding; but they are more numerous, and are arranged parallel to each other in two sets, between three carbon blocks B, B', B'' (figs. 35 and 36).



Fig. 35.

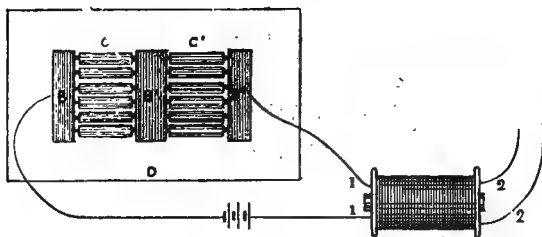

Fig. 36.

The diaphragm D is a deal board, which is fixed at a slight angle with the horizontal plane. It is fastened to a rubber frame C C', which is glued above the board F H, through which there is a hole at O to allow a free space for the carbons. The diaphragm is quite open, not being protected, as in the Crossley, by a board with a mouth-piece.

*Paul Bert and D'Arsonval's Transmitter.*²

The arrangement of the carbons on the diaphragm of this transmitter, which is fixed vertically (fig. 37), is similar to that of Hughes's microphone (p. 35), but the number of carbons is increased.

The special characteristic of the D'Arsonval transmitter is the method of regulating the pressure of the carbons. The carbon blocks B, B', B'' have conical



Fig. 37.

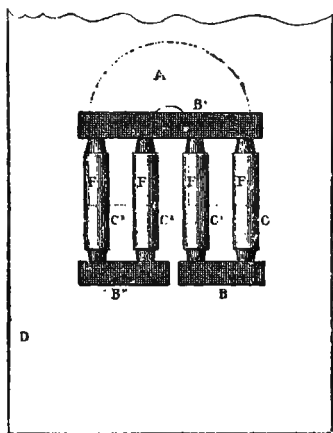

Fig. 38.

holes for the reception of the conical ends of the carbon pencils C, C¹, C², C³. The pencils are surrounded by a covering of thin sheet iron F, and behind them is a horseshoe magnet A, shown in section in fig. 37 and by dotted lines in fig. 38. This magnet, the position of which can be regulated by approaching it towards or withdrawing it from the carbons by means of a screw,

² *Sieur, "Etude sur la Téléphonie."*

attracts the iron covering of the carbons, so that, under the influence of the vibrations of the diaphragm D, their contact with the blocks B, B', B'' is modified without breaking, and produce the variations of resistance and of current strength required for the reproduction of articulate sound. It will be seen from fig. 38 that the carbon pencils are arranged in pairs, so that the current passes from block B simultaneously through the pencils C and C', through block B', then through the pencils C² and C³, and, leaving through block B'', completes its circuit through the primary wire of the induction coil, whose secondary wire is in connection with the line-wire, as in the systems already described. In fact, almost without exception, this arrangement in series and parallel is a feature of all pencil transmitters, as it tends to equalise the action and prevent irregularity due to the independent motion of the carbon.

*De Jongh's Transmitter.*³

The De Jongh transmitter is a very convenient and efficient form of pencil transmitter.

It consists of a diaphragm of pine wood, about $6\frac{1}{2}$ inches by $4\frac{1}{2}$ inches, to which are affixed two series of four carbon blocks, the surfaces of which are polished. The blocks in each set are connected together by means of a flexible wire, securely bound round each. Behind the diaphragm, at a distance of half an inch, is placed a base-board, into which are driven, at an angle of about 45° , two rows of brass pins, so arranged that polished carbon pencils placed horizontally across them will rest loosely against the carbon blocks fixed on the diaphragm.

³ British Patent Specification 16,082 (1884).

An indiarubber cushion separates the diaphragm from the base-board. The whole is mounted in a suitable case, which is fixed vertically in any convenient position. The pencils pressing loosely against the carbon blocks fixed to the diaphragm connect them together, and when the diaphragm is made to vibrate, the contacts are more or less affected, and the current correspondingly varied.

Fig. 39 shows a section of the instrument.

A is the base of the transmitter, into which are driven the pins P, P', P'', P'''.

B, B', B'', B''' are one set of blocks, bound around each of which is the soft copper wire.

C, C', C'', C''' are the carbon pencils pressing against and connecting together the two series of blocks. One of these pencils is shown separately at the side.

D is the diaphragm, which is clamped into position by the hinged front of the case, F.

G is the indiarubber cushion between the diaphragm and the base of the instrument.

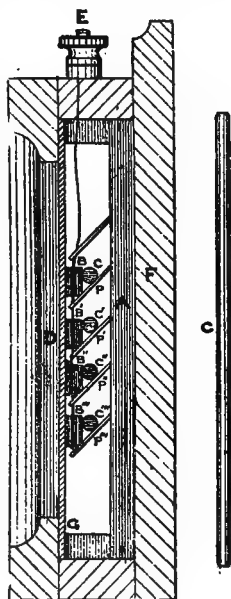

Fig. 39. $\frac{1}{2}$ full size.

*Mix & Genest's Transmitter.*⁴

This instrument, which has been extensively used by the German Post Office, is represented in figs. 40 and 41. The leading idea in the construction of this microphone

⁴ "Industries," August 19, 1887.

was to avoid accidental derangement of the carbon con-

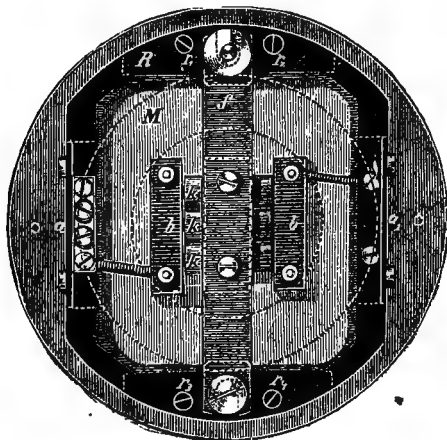

Fig. 40.

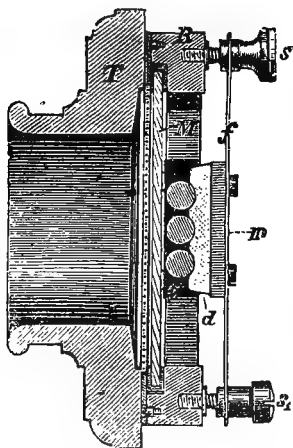

Fig. 41.

tacts while retaining the advantages of carbon pencils and a vertical position of the diaphragm. This is effected

by a sort of brake, which so holds the carbon pencils that they do not rest on the lower points of the holes in the carbon-holders. This prevents the pencils from taking up an independent rolling motion from the vibration of the diaphragm in the same direction, which is one of the probable causes of the jarring noise which characterises microphones with vertical diaphragms unless some such steps are taken. It may be observed that D'Arsonval secures this object by means of a magnet and iron-sheathed pencils (p. 65).

The mouthpiece *T* is screwed to a cast-iron ring *R*, which is grooved, and carries in the groove the diaphragm *M*, of thin pine-wood, surrounded as in the Blake, by an indiarubber band. Two clamps, *a a* (fig. 40) hold the diaphragm in position. Two carbon-holders *b*, fastened to the diaphragm, carry three carbon pencils *k* of the usual form. A spring *f* placed across the pencils acts as a brake, and carries a brass plate, between which and the carbon pencils a pad of some soft material, such as felt, is inserted.

By means of the screws *s* and *s*₁, the pencils *k* can be adjusted to slightly press against the carbon-holders, so that, although the pencils cannot roll, they yet remain sufficiently movable.

In the latest pattern the felt pad is replaced by three hog-hair brushes which are arranged to press lightly one upon each pencil. The adjustment slides the bar *f* up

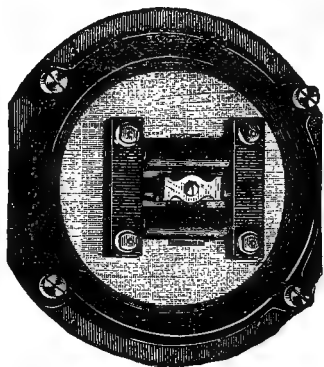

Fig. 42.

or down, so increasing or reducing the pressure of the brushes upon the pencils. This is, no doubt, a simpler and more sensitive adjustment. The principle of the hog-hair brushes is shown by fig. 42, which illustrates a smaller form of transmitter.

The "Johnson" Transmitter.

This is no doubt a very satisfactory transmitter for domestic purposes, or for use on short lines. The general arrangement is indicated in fig. 43; the two

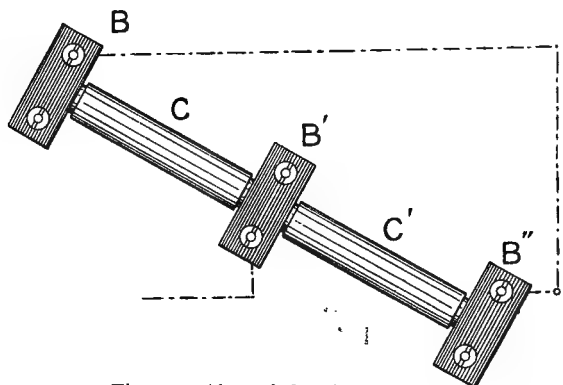

Fig. 43. About $\frac{2}{3}$ full size.

carbon pencils C, C' are mounted upon a thin pine diaphragm between three carbon blocks B, B', B'', which are connected as shown, so that practically the two pencils are joined in multiple. The diaphragm is fixed at a slight angle with the horizontal plane, as in the case of the Gower. The upper surface of the diaphragm is coated with a thin sheet of mica as a precaution against the effects of moisture-condensation during use.

It will be seen that the instrument is practically a

Hughes microphone pure and simple, with the pencils fitted angularly upon the diaphragm. It was devised principally with a view to supply a pencil transmitter free of the Crossley patent.

*Blake's Transmitter.*⁵

This is represented in figs. 44 and 45. The front of the case of the instrument, pierced in the centre and fitted with a mouthpiece *M*, carries on its reverse side an iron ring *r* (fig. 45), upon which are cast the two projecting pieces *b*, *b'*. Upon the upper projection is fixed the angle-piece *c*, by means of the flexible brass strip *m*, and the lower angle of *c* abuts against the end of the adjusting screw *n* fitted in the lower projection. Immediately behind the mouthpiece lies the diaphragm *D*. This is a circular iron disc, surrounded by a rubber ring *u* stretched over its periphery, and it is retained in position by two springs *v*₁ and *v*₂ (fig. 45), which are fixed to the ring *r*, and press respectively upon the rubber ring and upon the disc itself. At the extreme end of the short arm of the angle-

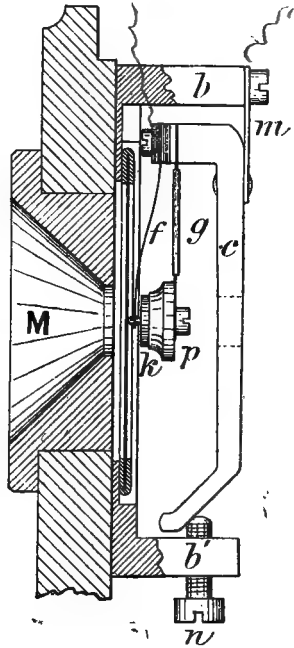

Fig. 44. $\frac{3}{8}$ full size.

⁵ British Patent Specification 229 (January 20, 1879).

piece *c* are fixed two springs *g* and *f*, one of which, *f*, is insulated from *c*. Spring *f* is of thin flexible steel fitted at its free end with a platinum contact. This free end presses against the centre of the diaphragm, and the platinum contact is pressed by the carbon disc *k* fastened upon the small brass plate *p* which forms the extremity of spring *g*. Springs *f* and *g* are therefore

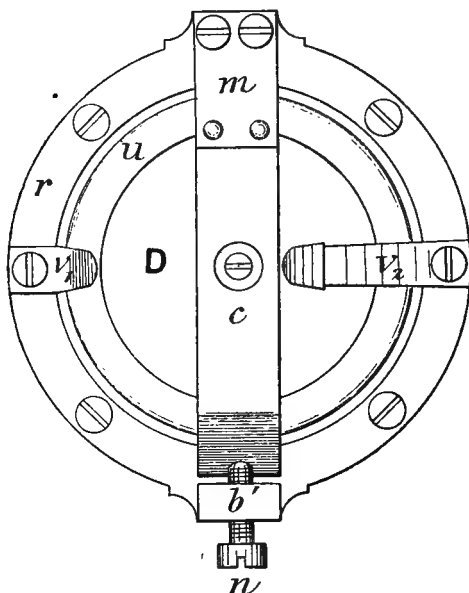

Fig. 45. $\frac{2}{3}$ full size.

in electrical connection only by means of the platinum contact and the carbon disc, being insulated at their upper ends.

The current passes from one pole of the battery through the primary coil to the ring *r*, the upper projection *b*, brass strip *m*, the short arm of the angle-

piece *c*, spring *g*, brass plate *p*, carbon disc *k*, the platinum contact of spring *f*, and back to the other pole of the battery.

If the diaphragm *D* be thrown into vibration, these vibrations are transmitted to spring *f*, so that the platinum contact presses more or less strongly against the carbon face of the plate *p*.

This transmitter is more extensively used than any other, and though it is by no means the best, it works so efficiently that it has held its place with great pertinacity against all rivals. Its articulation for short distances is very good, but when used for long distances it is decidedly inferior to some others.

Recent improvements in transmitters of the granular form are, however, now tending to the displacement of the Blake to some extent.

For switchboard use—where the transmitter is required to be suspended in front of the switch, and it is consequently important that it should be small and compact—"metal-cased" Blake transmitters are fitted. A very neat instrument of this class, manufactured by the Western Electric Company, is shown in figs. 46 and 47. The working parts are lettered to correspond with those of figs. 44 and 45. Access is obtained to

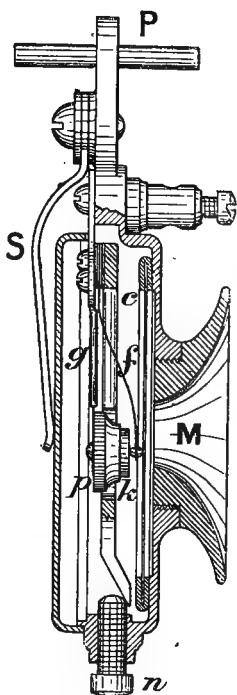

Fig. 46. $\frac{3}{4}$ full size.

the inside of the case by the removal of the back, which is effected by turning aside the stiff spring *S*, as indicated in fig. 47. The terminals are shown at the upper part of the case, and the pin *P* is for the purpose of suspending the instrument.

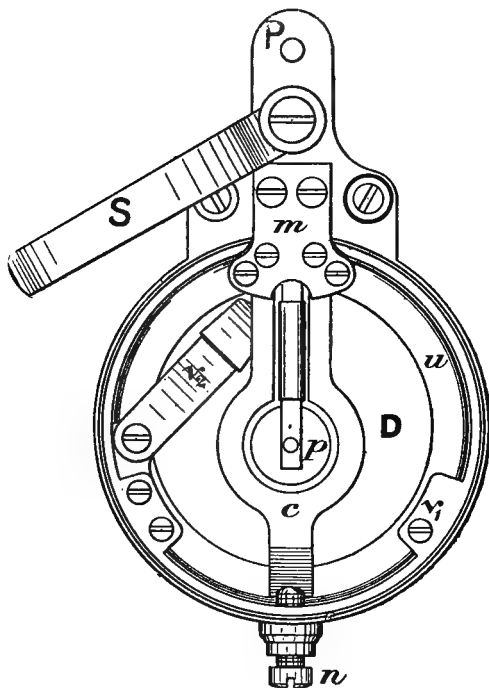

Fig. 47. $\frac{2}{3}$ full size.

*Maiché's Transmitter.*⁶

A carbon block *B* (fig. 48) is fixed to the centre of a very thin cork diaphragm *D* of $1\frac{1}{2}$ in. to 2 in. diameter. Against the block *B* rests a small carbon cylinder *C*,

⁶ Sieur, "Etude sur la Téléphonie."

attached to the vertical arm of a lever L, which is pivotted as shown, and upon whose screw-threaded horizontal arm is fitted a small weight E, which serves for regulating the pressure of the carbons. Maiche places three, four, or five discs similarly arranged on the same wooden board, and covers the front of the board with a piece of cloth or serge.

The contacts, as well as a corresponding number of induction coils, are, according to the conditions of resistance, placed in multiple or in series.

Gent's Transmitter.

This (figs. 49 and 50) is a very simple instrument of the Blake type with two contacts. In the figures, which are to a scale two-thirds full size, D is a wooden diaphragm clamped between indiarubber rings by a brass ring r . In

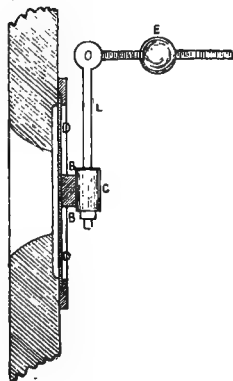

Fig. 48.

the centre of D is cemented and pinned a carbon button C, upon which rest the two carbon points C' of the weighted levers P, P', which are freely pivotted at a . The pressure of the points C' upon C is regulated by the position of the double screw-nuts w upon the second arm of the levers P. This transmitter gives very good results, especially for short lines.

*Locht-Labyé's Transmitter.*⁷

In the more usual forms of transmitters the diaphragm is held in a fixed position, either at each corner, on two opposite sides, or all round. In Locht-Labyé's

⁷ Sieur, "Étude sur la Téléphonie."

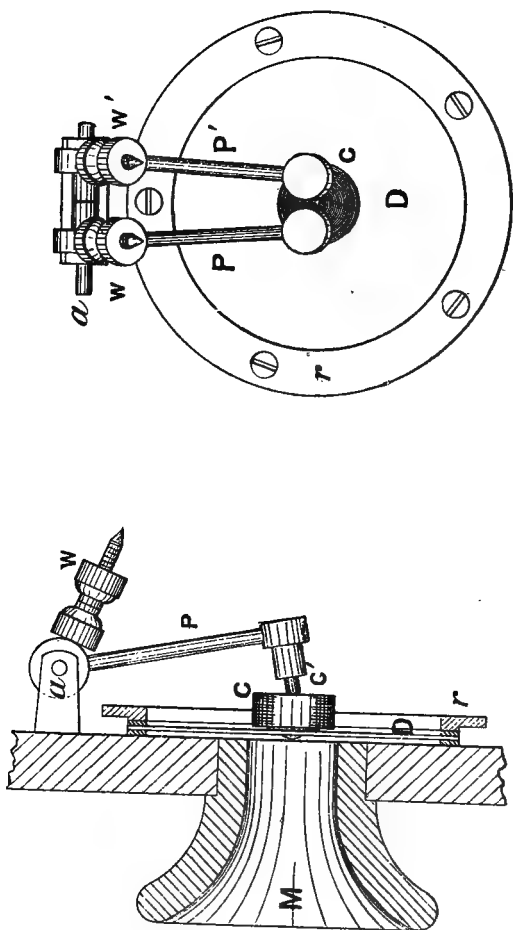
Fig. 49. $\frac{3}{8}$ full size.Fig. 50. $\frac{3}{8}$ full size.

apparatus, however (figs. 51 and 52), the small cork board L is simply fixed at its upper part by two very flexible spring-plates R, R. On the lower part of the board is fixed a carbon disc C, against which rests a metallic lever B.

The contact between the carbon disc and the abutting lever closes the circuit of the battery through the

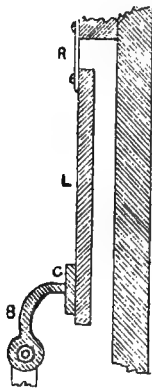

Fig. 51.

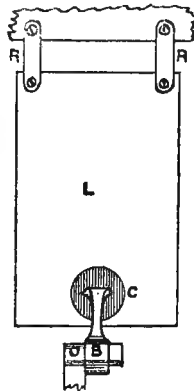

Fig. 52.

primary wire of the induction coil, whose secondary wire is, as usual, connected to line.

The lever B is pivotted at O, so as to admit of adjustment, which consists in causing a pressure of the end of the lever against the carbon disc sufficient to prevent any breaking of contact during the vibrations communicated to the board L by the action of the voice.

The transmitter and the induction coil are placed in a box covered by a piece of woollen cloth, which slightly deadens the vibrations of the air, and thus prevents, to a certain extent, the breaking of contact.

*Freeman's Transmitter.*⁸

With the object of strengthening the effects of the microphone, various attempts have been made to multiply the variations of current by double induction coils and other double actions. A number of transmitters (including some already described) may be classed under this category, and Freeman's is another example of this idea.

In its essential parts it is of the Blake type of transmitter. *a* (fig. 53) is a diaphragm, a projection on which

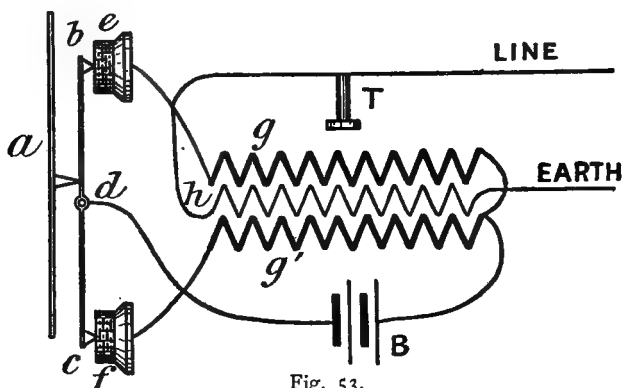

Fig. 53.

presses against the two-arm lever *bc*, whose fixed centre is *d*. At *b* and *c* two platinum contacts press on the carbon discs *e* and *f*. The primary wire of the induction coil is in two sections, one, *g*, being wound direct on the soft-iron wire core, and the other, *g'*, being wound outside the secondary wire *h*. The coil is surrounded by a casing of soft-iron, which produces on the spirals of *g'* the same effect as the core has on the spirals of *g*. The secondary wire *h* is connected, as usual, through

⁸ "Journal Télégraphique," 1887.

the telephone receiver T to the line. The local battery B is so placed in the circuit of the primary wires that two independent circuits are formed, one being B *g e b d* B, the other B *g' f c d* B. When the diaphragm vibrates, the resistances of these circuits are alternately augmented and diminished, the increase of one corresponding to the decrease of the other. A weakening of current in *g* is therefore always accompanied by a strengthening in *g'*, and *vice versa*. These variations of current are arranged to act in an inverse sense on the secondary circuit *h*, and so produce an increased effect. It is, however, doubtful whether any improvement is likely to arise in actual use.

Boudet's Transmitter.

This transmitter, represented in fig. 54, consists of a mouthpiece E attached to the extremity I of a glass tube T about two-fifths of an inch in diameter, which is itself fixed to a jointed support, so that the whole of the apparatus can be bent at any angle.

The mouthpiece carries a thin ebonite diaphragm D, to which is fastened a copper cylinder M¹ which projects into the glass tube, and which is in electrical connection with the upper terminal B. In this tube are placed six balls of hard carbon, of slightly smaller diameter than the tube, so as to allow them to move freely within it. Behind these is a second copper piece M², which is pressed upwards by a small spiral spring (not shown) in the cylindrical box K. The lower terminal B' is in electrical connection with M². The screw working in the stirrup Q regulates the pressure of the piece M² against the balls, which, of course, are thereby maintained in continuous connection with M¹.

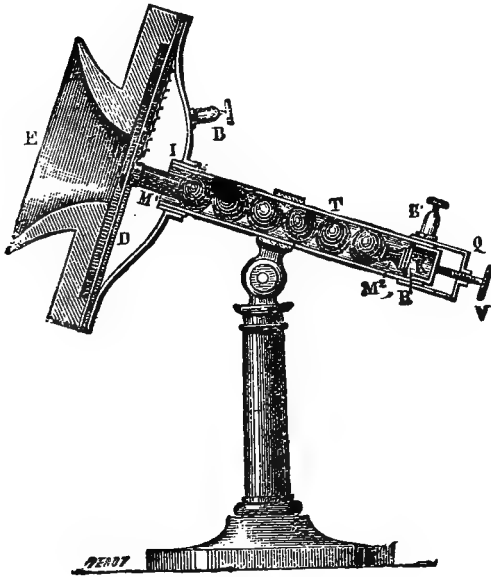

Fig. 54.

*Burnley's Transmitter.*⁹

The variations of contact between the two carbon electrodes *c* and *c'* (fig. 55) are produced by the vibrations of the two membranes *m* and *m'*, upon which they are fixed, and which are equally affected by the sound emitted before the mouthpiece *A*. The closeness of contact of the two electrodes is determined by the regulating screw *R*. A pad of cotton wool is sometimes placed in the space between the diaphragms, in order to damp down their abnormal vibrations without interfering with the effect of the sound waves which impinge upon them.

⁹ "La Lumière Electrique," 1886, p. 210.

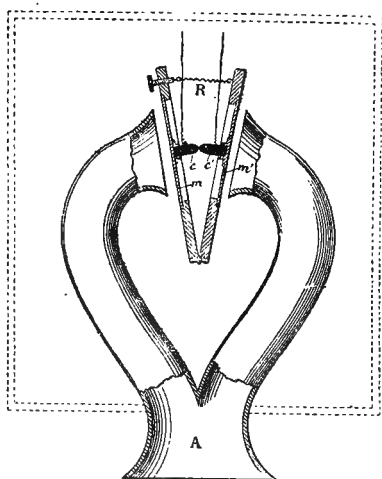

Fig. 55.

*Hunning's Transmitter.*¹

This was the first of the distinct, and for the most part very efficient, class known as *granular* transmitters. It consists of a front vibrating diaphragm of platinum foil, of about $2\frac{1}{4}$ in. diameter, behind which, at a distance of from $\frac{1}{16}$ to $\frac{1}{8}$ inch, is a fixed platinum or carbon plate. The space intervening between the diaphragm and the fixed plate is loosely filled with granulated carbon (ordinary oven-made engine-coke, powdered and sifted free from dust, is found to give the best results). The whole is mounted in a suitable case of wood provided with a mouthpiece, as shown in fig. 56.

To secure the diaphragm against damage, a grid of

¹ British Patent Specification 3,647 (Sept. 15, 1878).

fine wire gauze is inserted opposite the hole in the mouthpiece, and in front of the diaphragm.

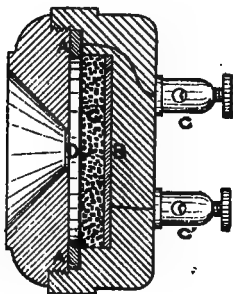

Fig. 56. $\frac{1}{2}$ full size.

The action of the instrument is as follows:—

When the platinum diaphragm is spoken against through the mouthpiece, its inner surface is brought more or less into contact with the coke granules, which causes varying pressure between them. The resistance which they offer to the current is thus varied with the amplitude of the vibrations of the platinum foil under the influence of the sound waves, and the current changes similarly.

Referring to fig. 56, A A is a ring of metal securing the platinum foil diaphragm D around its circumference ;

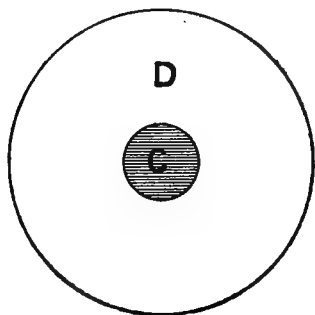

Fig. 57.

B is the back contact plate ; C, C' are the terminals for connecting the microphone to the battery and induction coil ; they are attached respectively to the ring A and the plate B. G is the granulated carbon inserted between D and B. The wire grid is clamped between A and the mouthpiece.

*Moseley's Transmitter.*²

Several important modifications of Hunning's transmitter were made by the late Charles Moseley, of Man-

² British Patent Specification (Provisional) 2,451 (May, 1882).

chester. The platinum diaphragm was replaced by a thin carbon disc, and the space between it and the back plate was wedge shaped, so as to secure uniform contact among the loose carbon particles. Further, in order to overcome to some extent the deteriorating effect of the granules becoming so set that the vibration of the diaphragm ceases to act upon them, the device was adopted of making the front electrode only a small disc C, in the centre of a thin pine diaphragm D (fig. 57). By this means the compacted granules at the bottom of the cavity are rendered inoperative.

Roulez's Transmitter.

This is the transmitter adopted by the French Administration for use on the London-Paris telephone circuits. As shown in fig. 58, D is a thin carbon disc about 4 inches in diameter, across the centre of which is fixed a carbon block, shown in section at C. This block is about $2\frac{3}{4}$ inches long, and has three recesses as shown. Its surface near the diaphragm is coated with paper to serve as insulation, and the block itself is fixed by means of insulated screws with nuts. The recesses are filled with broken filaments from incandescent electric lamps. The diaphragm is mounted in a wooden ring with india-rubber packing, upon a board with a central opening M.

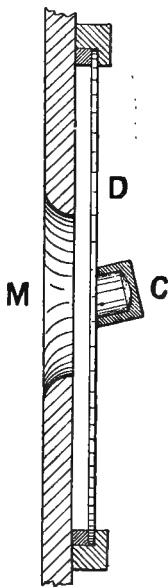

Fig. 58.
 $\frac{2}{3}$ full size.

Berliner's Universal Transmitter.

This is represented in fig. 59. It has the following construction :—

B is a wooden box with a screw-cover B'. On the edge of B a brass ring is fixed, against which is clamped the vibrating carbon plate D, so that good connection is secured for D. The second electrode is the carbon block C, in the lower surface of which are turned three concentric angular grooves. This block is fixed in

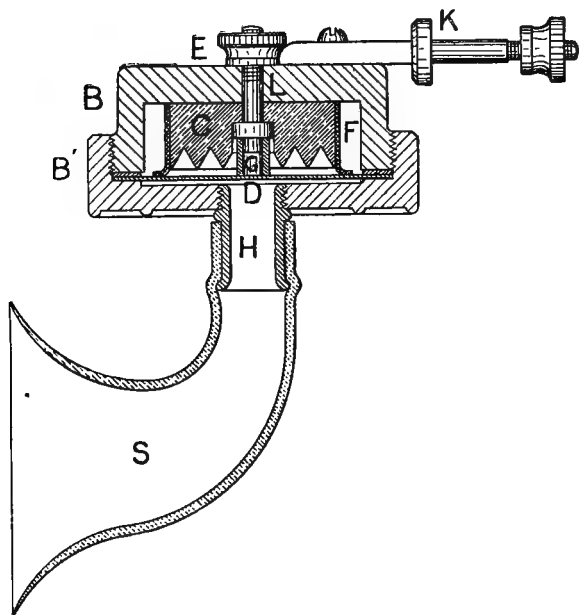

Fig. 59. $\frac{2}{3}$ full size.

position by a pin L, which is adjustable by means of a micrometer screw-nut E. The head of the pin L, which passes through the centre of the carbon block C, is turned down to receive a small rubber tube G, whose end lightly presses upon the carbon disc D, and thus damps down its vibrations. The carbon block is enclosed

in its entire circumference by a ring of felt F, whose lower rim likewise touches the membrane D. A closed space is thus formed between the carbon electrode, the felt ring, and the diaphragm, which is filled with carbon granules.

The special feature of this instrument is that the diaphragm is horizontal, with the granules lying above it, the idea being that as the diaphragm is shaken in use the granules are prevented from settling down, and also that condensation of moisture from the breath will not be so likely to cause serious trouble. It forms a very efficient transmitter. A cylindrical piece H is screwed in the cover B', and to it the indiarubber mouthpiece S is fastened.

By means of two bolts, which serve also for connections, and only one of which, K, is shown, the transmitter can be fixed to the front of any case.

*Berthon's Transmitter.*³

The Berthon transmitter (another modification of the Hunning's, p. 81) has been used to some considerable extent, especially in France. One form consists of two circular carbon plates P, P' (fig. 60) about $2\frac{3}{8}$ inches in diameter, separated from one another by an indiarubber ring B. An ebonite cupola C, three-quarters filled with granules of retort carbon, is placed in the centre of plate P'. When the apparatus is suspended the granules press against the exterior plate P' and establish microphonic contact. In the latest form of the instrument the granules are complete tiny balls, not merely fragments of carbon.

The whole is enclosed in an ebonite case A, in which it is held by a metal ring D, which screws into the

³ British Patent Specification 2,893 (March 4, 1885).

ebonite. Indiarubber rings are fitted at B' below the plate P', and at e, beneath the ring D. The bottom of the case is perforated with holes T, to permit of the free vibration of the lower plate. The connection of the terminals b, b' with the carbon plates is secured by means of slightly flattened platinum wires.

The most favourable angle at which to incline the plates is about 50° , and it is stated that in this position

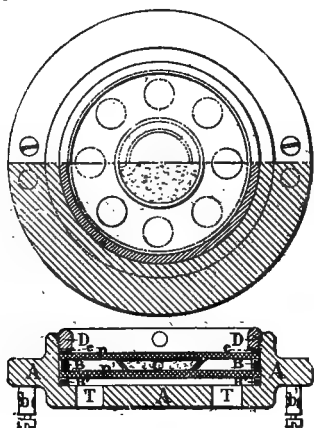

Fig. 60.

the apparatus is not only most sensitive, but that it is free from the disagreeable cracking noise which results from actual interruption of the microphone circuit

Thornberry's Transmitter.

Fig. 61 shows a section of this instrument, which has been very extensively used in America for long-distance speaking. In a shallow cylindrical brass box, the bottom of which is perforated in the centre, is placed the platinum-foil diaphragm D. Above this is an ebonite ring, while on the periphery of the brass box rests another ebonite

ring, within which, and resting upon the lower ring, is a thin brass cylinder C. Upon the upper edge of C rests a circular brass-piece B shaped as shown. The space in the cavity around this piece is nearly filled with coke granules. This whole combination is placed in a hollow chamber H, at the upper part of an iron casting which forms the case of the instrument. The brass cap L covers the whole. The mouthpiece M and general

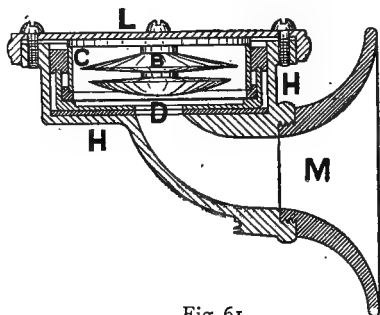

Fig. 61.

arrangement are of the Berliner type. The height of the instrument is adjustable upon a vertical rod, on which it is clamped by a set-screw.

The Western Electric Transmitter.

Although the general construction of this instrument follows on the lines of Berliner's "Universal," it is arranged only as a vertical transmitter. Referring to fig. 62, the thin metal diaphragm D is surrounded by a rubber ring, as in the Blake, and fitted into the metal cap B', being fixed by a wire ring sprung into the cap. The cap is itself fitted with a light, well-shaped mouth-piece M. Rivetted in the centre of the diaphragm is a very thin circular tray, the bottom of which has two circles of

indentations, and inside the rim of which is sewn a sleeve of flannel F. When the cap is screwed into position on the metal case B, the circular carbon block C fits into the sleeve F, so that the space for the carbon granules is very effectually enclosed. A short length of rubber tube projecting from the centre of the carbon block acts as a

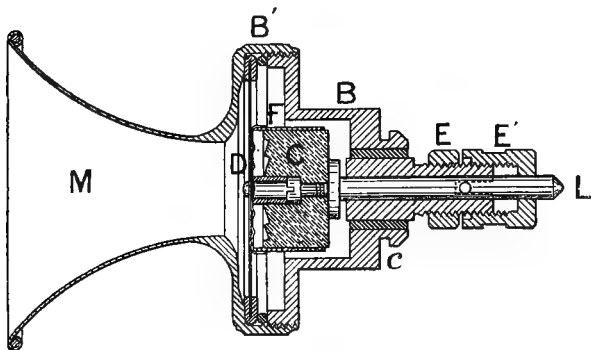

Fig. 62. $\frac{2}{3}$ full size.

damper on the diaphragm. The pressure of this damper is regulated thus: The carbon block is fixed upon a brass rod L, which slides in a thick cylinder fixed in the centre of, but insulated from, the case B. One end of this cylinder is screw-threaded, and has a deep slot across it; the nut E is first screwed over the cylinder, then a pin is passed through a hole in L across the slot, and over this is screwed the nut E'. The inner end of this latter nut is recessed so as to permit it to pass over the projecting ends of the cross-pin. The forward or backward motion of the nuts E, E', between which the cross-pin is clamped, then adjusts the position of C in



Fig. 63.

reference to the diaphragm. The outer circular groove in the face of the carbon block is drilled with a series of recesses, as shown in fig. 63.

The transmitter is fixed on its holder by a collar at *c*, which permits of its being turned round, and also furnishes one point of connection. The other connection is secured by the end of *L* pressing against a spring.

In the experimental trials of apparatus to be used on the London-Paris line this was one of those selected for the final experiments—the others were the Ader (p. 64), D'Arsonval (p. 65), Gower (p. 62), and Roulez (p. 83).

*The "Solid-Back" Transmitter.*⁴

As already noted, the great drawback of granular transmitters is the natural tendency of the granules to become "packed" after use, by reason of the vibrations of the diaphragm, and most of the variations on Hunning's original form have been made with a view to the elimination of this defect. The "solid back" is the latest American development in this direction. This (fig. 64) is the form of transmitter used upon the New York-Chicago telephone line, which is nearly a thousand miles long. It is made in this country by the Western Electric Company.

The two electrodes are small carbon discs, each soldered upon a brass plate of similar diameter, of which the back one has a screwed brass pin, by which it is fixed in the back of the hollow chamber of the thick brass-piece *B*, while the front plate has a threaded boss terminating in a threaded pin. The inner cylindrical surface of *B* is lined with paper. The carbon-faced discs

* "Electrical Engineer" (New York), vol. xiv., p. 477 (1892).

are slightly smaller in diameter than the hollow chamber, so that the intervening granules at the lower portion of the chamber are not in the direct path of the current. Clamped to the front electrode by a nut (shown in section) upon the screwed boss is a disc of mica whose diameter is equal to that of the threaded rim of B; and when a suitable quantity of the usual finely-divided anthracite carbon has been placed over the back electrode, the other is fitted over it and clamped by means of the capping, C. The flexibility of the mica permits of the

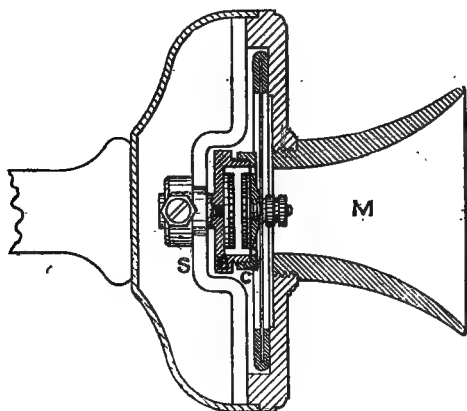

Fig. 64. $\frac{3}{4}$ full size.

movement of the front electrode relatively to the back. The back block B is rigidly fixed in the bridge-piece S, which extends across the case; and the screwed pin of the front electrode passes through the centre of the diaphragm and is fixed by two small nuts. The diaphragm, whose periphery is surrounded by a rubber band, is held in the metallic case by two rubber-tipped dampening springs as in the ordinary Blake transmitter.

The induction coil used is of a somewhat unusual type, being 6 inches long between cheeks and wound respectively to 3^o and about 14^o for the primary and secondary wires.

It is stated that extended trials of this transmitter—which is certainly clear and distinct in articulation—seem to indicate that the “packing” difficulty has been successfully overcome.

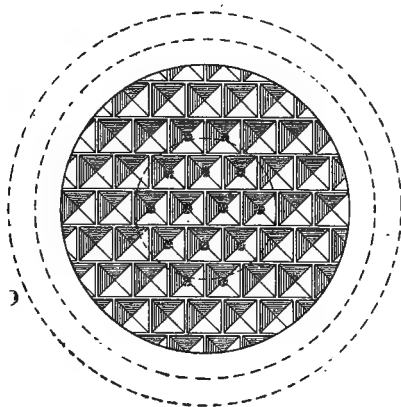

Fig. 65.

The Hunning “Cone” Transmitter.

This is a modification of a device of Deckert and Momolka, of Vienna, which gives very good results, but we are not aware that any independent tests of their permanent efficiency without “packing” of the granules have been made public. Fig. 65 is a front view of the back carbon plate. It will be seen that the whole surface is covered with “cones,” or, more accurately, pyramids, arranged in rows with alternate interspacings. The centre projections are slightly truncated, and tufts of silk are gummed upon them to act as “dampers” to

the front carbon diaphragm. The periphery of this latter is represented in the figure by the outer dotted line, and the two inner dotted lines indicate a ring of cotton wool which is fixed on the diaphragm, and forms a pad for retaining the granules, and also for regulating the vibrations. The granules are of graphited carbon, and are of a more or less definite form, although they are not uniform in size.

In connection with this transmitter attention has been specially drawn to the fact that was first pointed out by Professor Hughes,⁵ and was well known to many practical telephonists—that the reaction of the receiver upon the transmitter at one station on a circuit may be made to form a whistling “call” for the other stations. If, with the connections suitably arranged, a sufficiently powerful battery (about four or six Leclanché cells) be placed in the microphone circuit, and the microphone be caused to vibrate, the action upon the secondary circuit will, in the usual way, cause the receivers at the operating and the other stations to vibrate correspondingly. If now the receiver at the operating station be placed in a suitable position in front of the transmitter diaphragm, it will tend to keep the diaphragm in motion, and thus the two diaphragms will keep re-acting upon each other, causing a sound which will vary according to the natural rate of vibration of the discs. It will be clear from this description that, in order to make this an efficient “call,” considerable attention must be given to the relative sizes of the diaphragms. Deckert’s telephones give fairly good results, but most granular transmitters would probably lend themselves to the device more or less satisfactorily.

⁵ “Telegraphic Journal,” vol. vi., p. 255 (1878).

CHAPTER VI.

EXAMPLES OF TELEPHONIC RESEARCH.

IT is proposed in this chapter to describe some special forms of telephone which, though less practical than most of those hitherto illustrated, are interesting principally as indicating the wide field over which experiment has ranged.

In the first place may be described an instrument to which allusion has already been made (p. 2), and which may be fairly considered the pioneer of electrical telephones. This is

Reis' Telephone.

As early as 1860 Philip Reis constructed this apparatus, by means of which music produced in one place could be transmitted to a great distance. The instrument is represented in figs. 66 and 67, which are respectively the transmitter and the receiver.

At the station where the tune is played a mouthpiece T, leading into the box K, receives the vibrations of the air produced by the musical instrument. In the upper part of the box is stretched a membrane *m*, which vibrates in unison with the vibrations it receives. These movements interrupt the circuit of an electric current in

the following way : Let us suppose one pole of a battery, whose other pole is to earth, connected to the terminal marked 2 in fig. 66, from which a metallic conductor, formed of a thin copper strip *i*, goes to a platinum disc *o*, in the middle of the diaphragm. Barely clear of this disc is a point fixed beneath the angle of the piece *a b c*. Each time the membrane *m* is raised, the point will touch the disc, and a current will be established ; while on the other hand the current is interrupted on the recession of the membrane and when it returns to a state of rest. The line-wire is connected to terminal 1.

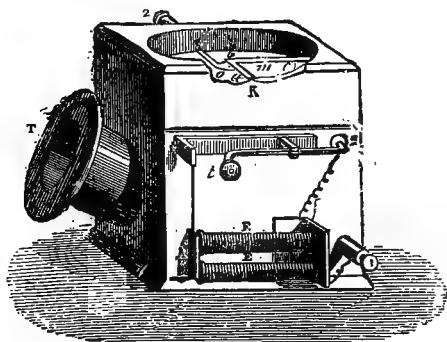

Fig. 66.

The receiver (fig. 67) consists of an iron rod *d*, surrounded by a spiral *g* of insulated copper wire, one of the extremities of which is connected through terminal 3 to line, while the other terminal 4 is connected direct to earth, thus completing the circuit.

The rod *d* is mounted upon a hollow box *B*, made of very thin wood, and a cover *D* fits over the coil. The whole of this arrangement is intended to strengthen the effect produced by the successive interruptions of the current. The principle is the same as in a piano,

where the intensity of the notes is increased by the resonance of the case. The sounds reproduced by the receiver result from the alternate magnetisation and demagnetisation of the core d , which, by causing certain alterations in the molecular arrangement of the mass of the rod give rise to vibration of the resonant case. The vibrations of the rod d exactly synchronise with those of the membrane m , and consequently with those of the instrument playing the tune. Not only is the time correct, but also the relative amplitude, so that two of the factors which constitute music—

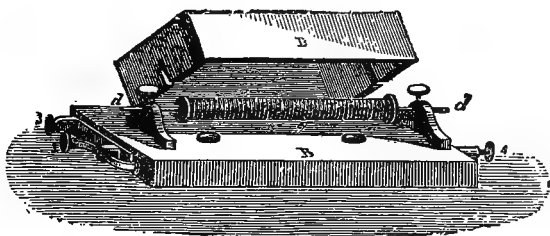

Fig. 67.

pitch and loudness—are faithfully reproduced: timbre only is wanting.

The form to be given to the box κ is an important factor in the construction of the transmitter; it was found advantageous to make the sides of curved boards. The efficiency of the receiver also was increased by introducing several iron rods into the coil; the sound, which was in the first instance muffled, was then much improved. There can be no doubt, as has been already stated (p. 3), that Reis's instrument could and did reproduce articulate speech before Bell ever thought of his telephone; but this is only one illus.

tration of an often-proved fact—that it is one thing to make a great discovery, and quite another thing to make it commercially useful.

Edison's Electromotograph.

If a sheet of blotting-paper be soaked in a saturated solution of caustic potash, and placed on a metallic plate connected with the positive pole of a battery composed of two or three Leclanché cells, and a narrow strip of platinum foil be then passed over the surface of the paper, exercising a certain pressure on the foil, a resistance to the sliding motion will be felt, owing to the friction of the foil against the paper, which possesses a certain roughness of surface. If the platinum foil while sliding over the paper be connected with the negative pole of the battery, the resistance to the sliding will be diminished to a very great extent when the current flows. The electric current, therefore, may be said to have the effect of smoothing, or lubricating as it were, the rough surface of the paper. This effect of the electric current is proportionate to the current; it commences and ceases with it, and is so sensitive that the feeblest currents—those, for instance, which have no sensible effect upon an electro-magnet—are rendered quite perceptible.

In the instrument shown in fig. 68, a thin diaphragm of mica, about $3\frac{1}{2}$ inches in diameter, carries in its centre a strip of platinum C, which presses against the cylinder A with a constant pressure, due to the spring S, regulated by the screw E.

The cylinder A is of chalk or of a paste consisting of lime, caustic potash, and a small quantity of mercuric acetate. When of chalk, it is moistened with

an easily decomposable electrolyte like potassic iodide. This takes the place of the paper soaked in potash in the preceding experiment. The cylinder is turned with a regular motion, either by means of a handle *w*, or by clockwork.

The electric current coming from the transmitter passes by the support *H* to the cylinder *A*, and thence

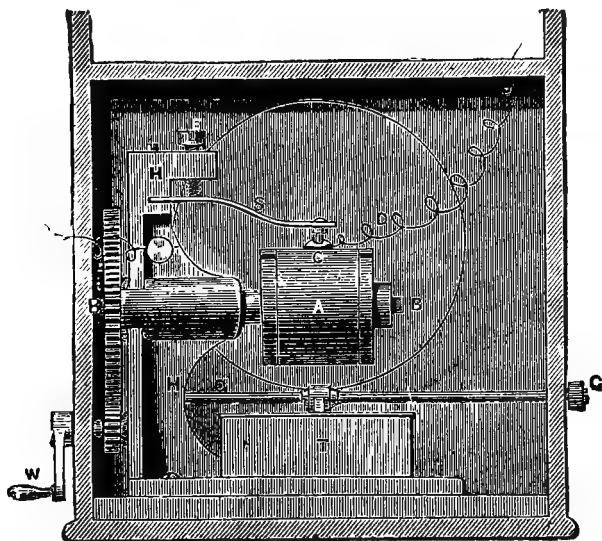

Fig. 68.

by the platinum strip *C* and the wire *D* to earth. By turning the cylinder in the direction of the hands of a watch, the friction between the strip *C* and the surface of the cylinder produces traction on the strip *C*. The mica disc, on account of its elasticity, takes up a position which depends on the friction between *A* and *C*; and as each variation of

H

the current which traverses A and C produces a variation in the traction of strip C, this causes a certain displacement of the mica disc, which thus vibrates synchronously with the undulatory current, and, consequently, synchronously with the membrane of the transmitter. The vibratory motion of the mica disc is, therefore, not obtained directly by the electric current, but is produced mechanically by the rotation of the cylinder A. The current merely effects a reduction of the friction.

The handle may be turned in either direction, as the platinum strip C acts equally well by pulling or by pushing the mica disc. The substance with which the cylinder is coated must be always kept moist, and this is secured by raising from time to time, by means of G, a small roller immersed in a solution of caustic potash which is contained in the reservoir T.

The sounds emitted are very loud, and can be heard over a large hall, but the articulation is very indistinct.

Bréguet's Mercury Telephone.

Although Antoine Bréguet's conception of the utilisation of the action and reaction of electric currents and capillary forces has not hitherto been of practical use, it is so distinctive an idea as to call for notice.

The point of a capillary tube (T, fig. 69) containing mercury, plunges into a vessel, V. This vessel is partly filled with mercury M', and partly with acidulated water A; the capillary point does not reach the mercury, but dips only into the dilute acid.

Two platinum wires P and Q communicate respectively with the mercury in T and that in V.

If the two wires be connected with one another, the level of the mercury in the capillary tube will be

established at an invariable height. But if a battery be interpolated in the circuit of the platinum wires, the level will assume another position of equilibrium, depending on the potential difference. A definite level of the mercury will correspond to each difference of potential. Above the mercury in the tube is a small air-chamber *S*, closed by a diaphragm *B*, the pressure on which will evidently vary every time the level of the mercury varies.

The apparatus also is reversible; that is to say, if by some modification of the pressure in *S* the level of the mercury suffers displacement, a difference of the potential will result in the two conductors *P* and *Q*.

Now, if two similar instruments be joined in one circuit, when pressure is exercised at *S*, a change in the level of the mercury in the tube of the second apparatus will at once be produced. Thus on speaking above the tube *T*, the air contained in this tube is caused to vibrate, and these vibrations communicated to the mercury give rise in the receiving apparatus to exactly corresponding vibrations of the air in the upper part of the tube; so that all the words pronounced into the tube are feebly reproduced by the diaphragm of the receiving instrument.

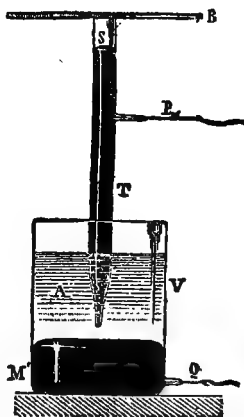

Fig. 69.

Preece's Thermo-Telephone Receiver.¹

The experimental form of this instrument is shown by fig. 70. On a stout mahogany base A was fitted a sliding brass pillar C, which could be fixed at any distance from D, a disc of thin iron. Part of a fine wire P was stretched between the centre of the disc and the screw on C. Its loose ends were connected

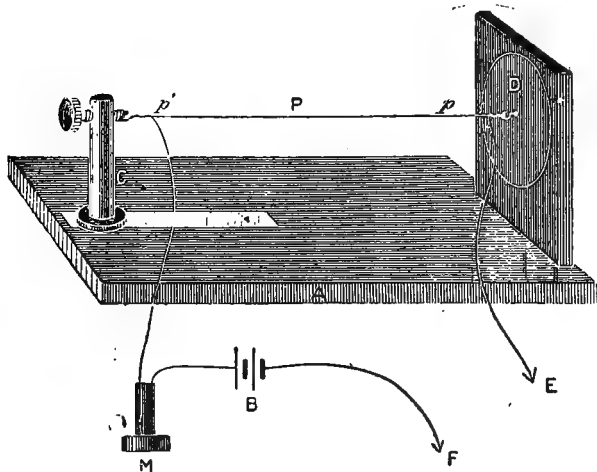

Fig. 70.

to terminals on the base, so that P might be inserted in circuit with a microphone transmitter M and a battery B of six potassium bichromate cells.

A platinum wire of 3 mils diameter, and 6 inches long from p to p' , was used, and the sonorous effects were very marked when the microphone transmitter M was spoken into. The articulation, though faint, was clear, and words could easily be heard.

¹ "Proceedings of the Royal Society," April 28, 1880.

*Forbes' Thermal Transmitter.*²

Professor G. Forbes made some experiments with a red-hot wire as a telephone transmitter. A fine platinum wire was included in the circuit of a charged accumulator and the primary wire of an induction coil. A receiving telephone was connected in circuit with the secondary wire of the induction coil. The battery power was such that the fine wire in the primary circuit was heated to a high temperature and rendered incandescent. When in this condition, words spoken towards it could be heard in the receiving telephone. The explanation of the phenomenon is that the sound waves passing the incandescent wire in quick succession altered its resistance by cooling, and thus varied the strength of current in the primary circuit. The fluctuations of current thus caused excited corresponding fluctuations in the secondary circuit, and these reproduced the voice in the receiver. Spiral wires in the form of watch-springs, of steel and platinum-iridium, were tried in place of the straight wire with some success. An indiarubber diaphragm when interposed between the voice and the heated wire did not interfere with the efficiency; but mechanical vibration had no effect whatever upon the apparatus.

*Dolbear's Receiver.*³

This, the invention of Professor A. E. Dolbear, of Boston, was assuredly the most simple conception for the reproduction of speech that is possible. It consisted

² Professor George Forbes, F.R.S., on 'A Thermal Telephone Transmitter.' Proc. Royal Society, 1887.

³ "Journal Soc. Tel. Engineers," vol. xi., p. 130 (1882).

of two conducting discs brought close together to form the two plates of a small "condenser." The line-connections were made to each disc, and the charge and discharge, or the variation of tension between the opposed plates, was made the means of producing the necessary vibrations.

The simplification of the receiver, however, resulted in the need of a very powerful transmitter and induction coil; and in experimental trials it proved impossible to receive properly while the very high resistance secondary coil was in circuit at the receiving end. The transmitter used was of the Hunning type.

CHAPTER VII.

THE COMPARATIVE EFFICIENCY OF SOME
TRANSMITTERS AND INDUCTION COILS.

VERY slight consideration will make it abundantly plain that a comparison of different telephone transmitters or receivers can scarcely be made with the same exactness as can be insured in the comparison of apparatus of a more mechanical character. The efficiency, for instance, of different telegraph sounders, or relays, or of two dynamo machines, may be compared with considerable accuracy; but in the case of telephonic apparatus the fact that the recorded results depend for the most part upon the ears of the observers introduces a factor of great uncertainty, and although certain transmitters are generally admitted to be of a high efficiency, it is rarely that several persons agree on the superiority of one particular form. It is, however, admitted that the slight differences which do exist cannot ordinarily be detected except by a very practised ear.

Professor Charles R. Cross, of Boston,¹ has recorded some practical tests made with a view to determine the relative efficiency of the Edison, Hunning, and Blake

¹ Rothen, "Journal Télégraphique," 1887.

transmitters, and so arranged as to be independent of personal error. For this purpose he passed the currents produced in the secondary wire through a very sensitive Kohlrausch dynamometer, having a resistance of 206 ohms. The vowels *a*, *i*, *o*, *u* were sounded, and also an organ pipe giving 512 vibrations per second.

The following were the results in milli-ampères :—

Transmitters.	<i>a</i> .	<i>i</i> .	<i>o</i> .	<i>u</i> .	Organ Pipe.
Edison ...	·088	·072	·123	·144	·072
Blake ...	·123	—	·144	·144	·132
Hunning ...	·737	·213	·787	·503	·556

These figures clearly show that the Edison transmitter, with its lampblack lozenge, although its reproduction is very clear, gives relatively feeble variations, and that the Hunning is remarkable for its powerful effects. This is in accordance with the general experience that granular transmitters are extremely good when they are in working order (p. 81).

One series of experiments made by the British Post Office authorities² was as follows :—

Four different forms of transmitters used in connection with various Continental exchange systems were obtained and compared with that used in the Gower-Bell instrument (p. 62). They comprised the well-known forms of D'Arsonval (p. 65), Berliner (p. 83), De Jongh (p. 66), and Mix & Genest (p. 67).

An artificial line was employed in making the tests. This consisted of a series of double-wound resistance coils and condensers, made up of 60 sections, each coil of which had a resistance of 33 ohms, and each section of condenser a capacity of 1 microfarad. Fig. 71 shows

² Proc. Royal Society (1887), W. H. Preece "On the Limiting Distance of Speech by Telephone."

a plan of part of the switch, and fig. 72, the "line" in diagram form. The arrangement of the "line" is such that it can be adjusted to any capacity in microfarads, and to any resistance (in gradations of 33 ohms), independently one of the other. For the experiments in question, however, the number of sections of capacity and of resistance were always equal. The comparison

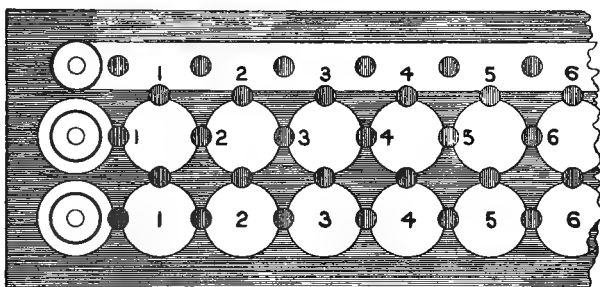

Fig. 71. $\frac{1}{2}$ full size.

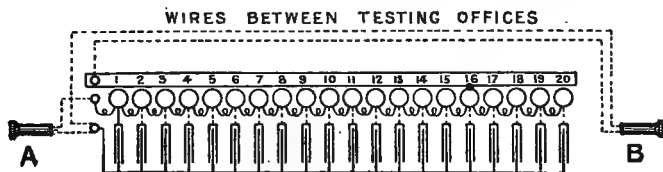

Fig. 72.

was made by ascertaining the point at which articulation became indistinct with the different transmitters. The transmitters were connected to a switch by means of which any one of them could be instantly joined in circuit with the same induction coil practically without interrupting the speaking, the remaining portion of the apparatus being undisturbed.

The results are shown in the following table. The

fourth column—the product of the capacity of the circuit (K) and the resistance (R)—represents the point at which articulation completely failed with each transmitter.

Transmitter under test.	Resistance R	Capacity K	$K \times R$	Remarks.
	Ohms.	Micro- farads.		
D'Arsonval.....	858	26	22,308	This result was only obtained after very careful adjustment. This transmitter was affected by moisture, and the $K \times R$ fell to 13,260 after 2 minutes' speaking.
Berliner	759	23	17,457	
Gower-Bell	693	21	14,553	
De Jongh	693	21	14,553	
Mix and Genest	462	14	6,468	

These results also bear out general practical experience. In such an instrument as a microphone, dependence upon an adjustment, however simple, is really a grave source of weakness; while, although granular transmitters are, as already stated, in many respects extremely good, a recognised weak point of many forms is that they are affected by moisture.

The induction coil of course plays an important part in the intensity and clearness of the reproduction. As a matter of fact it probably plays a much more important part than is generally supposed, and there can be little doubt that a large number of transmitters might be sensibly improved by choosing more suitable induction coils. In these coils, as has been shown at p. 12, the number of windings of each circuit is the essential, and the actual resistance is only the secondary, consideration;

the length and the thickness of the coils must therefore be taken into account.

The administration of the Swiss Telephone Department made a very complete series of tests with ten different coils in connection with the Blake transmitter. The experiments were conducted by M. Abrezol, the coils being wound as shown by the following table:—

No. of Coil.	Primary Wire.			Secondary Wire.		
	Number of Convolutions.	Diameter of Wire.	Resistance.	Number of Convolutions.	Diameter of Wire.	Resistance.
		mm.	ohms		mm.	ohms
1	61	'5	'25	1,956	'15	100
2	62	'5	'25	3,191	'15	180
3	62	'5	'25	4,080	'15	250
4	116	'5	'50	3,952	'15	250
5	230	'5	1'00	3,865	'15	250
6	232	'5	1'20	4,420	'15	300
7	295	'5	1'50	4,278	'15	300
8	368	'5	2'00	4,735	'15	350
9	368	'75	1'17	4,735	'30	130'2
10	1,350	'5	10'00	3,950	'15	400

By means of a switch any one of these ten coils could, without loss of time, be placed in the testing circuit, and the observer could quickly and easily pass in review the whole of the coils by retaining the impression produced from one test till the next. The experiments were made on five actual circuits, ranging in length from '5 to 107'4 kilometres, and the results, which were obtained by using a good Blake microphone of American make, were compared with its ordinary induction coil, whose primary wire had a resistance of 1'05 and secondary of 180 ohms. The sizes of wire and number of convolutions of this coil do not appear to have been recorded.

Expressing by the figure 1 the intensity and clearness

of the standard coil, the ten coils gave the following results:—

Distances (Kilometres).	Induction Coil.									
	1	2	3	4	5	6	7	8	9	10
5	.3	.7	.9	1.5	1.3	1.5	1.3	1.3	1.7	.3
	.9	.9	.9	1.3	1.0	.9	.9	1.0	1.0	.3
61.6	.9	1.0	1.0	1.7	1.3	1.6	1.5	1.5	1.6	.3
	1.0	1.1	1.3	1.5	1.2	.9	.9	.9	.9	.5
79.1	.3	.9	.9	1.3	1.1	1.7	1.1	1.1	1.7	.3
	.7	1.0	1.0	1.5	1.3	1.3	1.1	1.0	1.4	.3
85.3	.7	1.0	.9	1.3	1.3	1.7	1.5	1.5	1.6	.3
	.8	1.3	1.3	1.5	1.5	1.6	1.4	1.4	1.6	.4
107.4	.2	.7	.6	1.2	1.0	1.5	1.6	1.6	1.7	.3
	.9	1.0	1.0	1.5	1.3	1.5	1.3	1.2	1.3	.1

The upper row of figures opposite each distance represents the comparative "intensity," and the second row the comparative "clearness."

From this table, which, taking into consideration the nature of the tests, shows a remarkable concordance, it will be seen at once that the coils Nos. 1 and 10 must be rejected. Coils Nos. 4, 6, and 9 gave the best results; coil No. 4 is the only one which, under all circumstances, gave clearer and more intense reproductions than the standard instrument. The clearness of reproduction gradually disappeared with the increase of length in the actual circuit, and the sound became more diffused and muffled, due to the interfering and retarding effects of self-induction. In this respect coil No. 9 is especially remarkable, at long distances it surpassed No. 4; but, since the same microphone must serve as well for the short lines of a system as for the long ones a

mean must be adopted, and therefore No. 4 ought to be selected.

It is well recognised, however, that the coil which gives the best result with the Blake transmitter does not behave equally well with others, and to be exhaustive the experiments made with one single class of transmitters ought therefore to be multiplied.

The series of experiments referred to above (p. 105), as having been conducted by the British Post Office authorities, also included a comparison of the relative efficiency of the various induction coils with which the several transmitters were fitted, the circuit being again arranged so that any one of the coils could be substituted for another by means of the switch while the speaking continued and all other conditions remained unchanged. In this case it was not possible to know the number of convolutions, etc., as given in the Swiss experiments, but the dimensions of the coils indicate the conditions to some extent. The results in the limit of speaking upon the artificial line are given below:—

Coil Tested.	Dimensions.		Resistance.		Speaking limit (K × R)
	Length (inside cheeks).	Outside Diameter	Primary	Secondary	
	Inches.	Inches.	Ohms.	Ohms.	
Gower-Bell..	3 $\frac{1}{4}$	1 $\frac{1}{2}$	·5	250	14,553
D'Arsonval..	2 $\frac{1}{8}$	1 $\frac{1}{8}$	·7	173	13,200
Berliner	2 $\frac{1}{2}$	1 $\frac{1}{4}$	·6	188	13,200
De Jongh ...	3 $\frac{1}{4}$	1 $\frac{3}{8}$	·22	143	10,692
Mix & Genest	1 $\frac{1}{4}$	7/8	1·0	157	13,200

These results coincide very remarkably with those obtained by the Swiss Administration, inasmuch as the Gower-Bell standard induction coil as adopted by the

Post Office, which showed best in these experiments, exactly corresponds with the coil adopted by the Swiss on the basis of their experiments. The sizes of the primary and secondary wires in the Gower-Bell coil are respectively 50 and 5 mils. There are eight layers of primary and seven layers of secondary wires.

It must, however, be frankly admitted that other combinations of coils may be equally efficient. For instance, in the Post Office Telephone (p. 146), in which the Gower-Bell microphone is used, the primary coil has a resistance of $\cdot 5^{\circ}$, with 25 mils wire, and the secondary coil a resistance of 150° with 5 mils wire. The results with this coil were found to be indistinguishable from those with the Gower-Bell coil. This applies also to the induction coil used with the "solid-back" transmitter (p. 91).

PART II.
APPARATUS AND CIRCUITS.

CHAPTER VIII.

COMPLEMENTARY APPARATUS USED WITH
TELEPHONES.

BEFORE proceeding to illustrate some of the more usual types of complete telephone instruments it is desirable to describe certain necessary adjuncts for a telephone installation.

I.—THE AUTOMATIC SWITCH.

It is clear that means must be provided by which the calling or speaking part of the apparatus may be inserted at will. This applies to every case except where a "reed" or similar call is used (pp. 42 and 44). It is also necessary to provide for joining-up and disconnecting the microphone circuit. At first this was done by means of an ordinary switch, but experience soon showed that users frequently forgot to restore the switch to its calling position, so practically breaking down the line. Hence the introduction of the *automatic* switch, by which the required operation is effected in the act of replacing the receiver in its proper position.

The principle of the automatic switch may be understood from fig. 73, which shows the German two-contact

switch. On a brass upright piece, *s*, mounted on a base-board, is pivoted a lever one extremity of which is bent in the form of a hook *c*. This hook projects through the front board of the telephone case, and on it is suspended the telephone with its flexible conductors. When the receiver is *not* suspended upon the hook, the spiral spring *f* holds the inner end of the lever against the contact *a*. As soon, however, as the telephone is suspended, its weight pulls down the lever, whose inner end is then pressed against the contact-screw *r*.

The line is connected to the lever, and the speaking and calling parts of the apparatus respectively to *a*

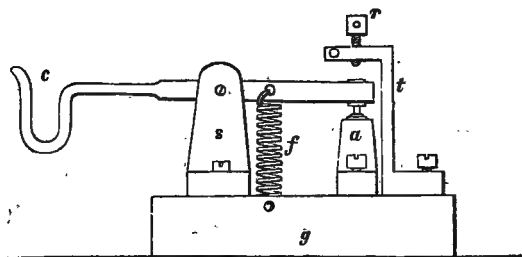

Fig. 73.

and *t*. Hence the call-bell can sound only when the lever presses against the contact *r*, so that when the receiver is not in use it must always be on the hook.

Where, as is generally the case, a microphone transmitter is employed, on the removal of the telephone from the hook the primary circuit of the induction coil must be closed, and the construction of the automatic switch is, therefore, altered to complete a second circuit when the receiver is lifted. When two receivers are used, a second and distinct switch is sometimes provided for this purpose.

II.—LIGHTNING PROTECTORS.

In order to protect the apparatus against damage by lightning, it is usual to provide each set with a *lightning protector* or *arrester*. These generally are of the very simplest description, that ordinarily used being of the form shown in fig. 74.

It consists of two brass plates with sharp saw-teeth fixed near together; the line-wire is connected to one plate and the earth-connection is made to the other. The plates are sometimes made adjustable with regard to each other, as the efficiency of the instrument depends upon the lightning discharge being able to leap across the space intervening between the points.

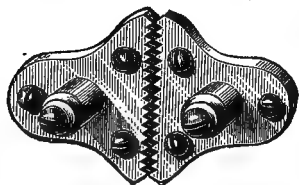

Fig. 74.

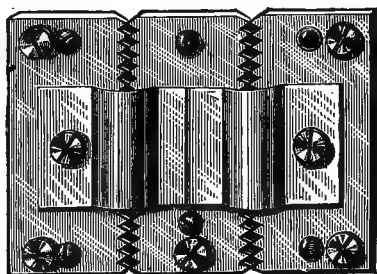

Fig. 75.

If the circuit is metallic, or the instrument is intermediate, each line is brought to a separate plate facing an earth-bar common to each. Fig. 75 shows the form of double protector used by the Austrian Government, in which, in addition to the serrated edges, each line-plate is fitted with a spring brought over the earth-bar, but prevented from actually touching it by the interposition of a strip of silk.

The Post Office pattern of lightning protector for single lines is shown in fig. 76. It consists simply

of two circular brass discs having perfectly flat faces which are tinned. Between these two faces is placed a disc of mica with three perforations around a central hole. The upper (or front) plate is fixed to the lower by means of a terminal, insulated from A by an ebonite collet *c*, which is faced with a brass washer between which and A the line-wire is clamped. The protectors are fixed upon bases singly or in groups, and the earth-connection is made to the terminal E through the back screw *e* and a plate which is fixed at the back of the wooden base.

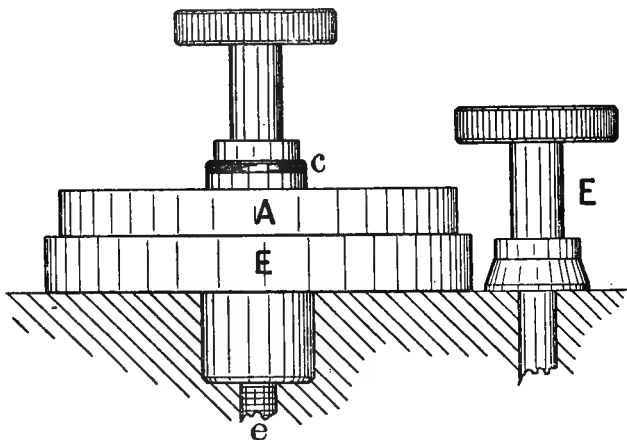

Fig. 76. Full size.

A somewhat similar arrangement is used upon double-wire circuits. This is shown in fig. 77. In this case the centre-plate is the earth-connection, and the two lines are joined to the upper and lower plates (A and B). The bosses upon the two upper plates serve both to secure a good screw-connection and, by fitting in holes provided in the base, also ensure the plates being in their proper positions.

The German Postal Administration has introduced for telephonic purposes an elaborated form of the reel or tube, lightning-protector, which possesses several features of interest.

The apparatus, represented by fig. 78, consists essentially of three brass cylinders m_1 , M , m_2 , fitted upon a common spindle, but insulated from one another. The middle cylinder M is directly soldered on the spindle s , and its two extremities are turned down to a smaller diameter than the central portion. The cylinders at

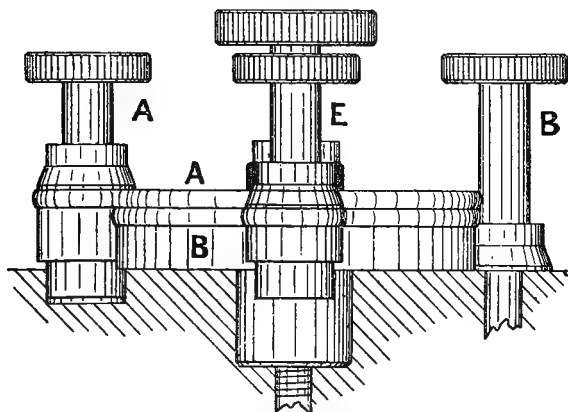

Fig. 77. Full size.

each end, m_1 and m_2 , are insulated from the spindle and from M by means of ebonite collets. On the reduced ends of M is wound a single layer of silk-covered wire about 40 mils in diameter, which passes from one end of M to the other, crossing the central portion of M in a groove made for the purpose. The two ends of this wire are passed across the ebonite collets and the cylinders m_1 and m_2 in similar grooves, and clamped respectively into electrical connection with those

cylinders by means of the nut n and the disc a . The two cylinders m_1 and m_2 are thus brought into electrical connection, whilst the cylinder M is insulated from them by the silk covering of the wire. The spindle is inserted into three brass blocks p_1 , p_2 , and p_3 , in which it fits accurately; good electrical connection is further ensured by the metallic springs f , which press against flattened portions of the cylinders m_1 , M , and m_2 . The left-hand

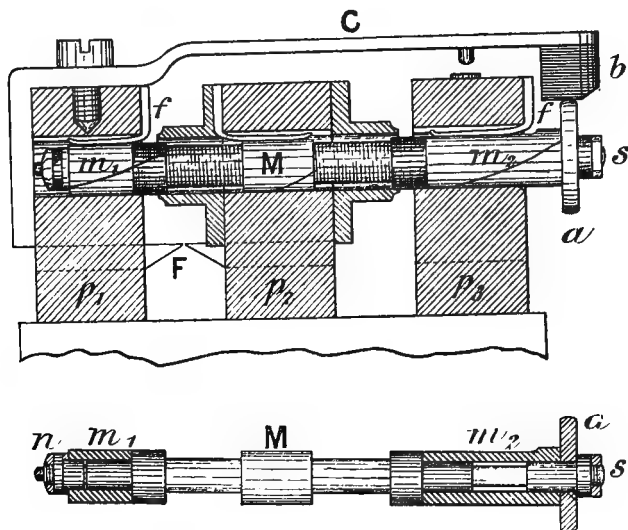

Fig. 78. Full size.

block, p_1 , is connected to the wire leading to the apparatus, the right-hand one, p_3 , to line, and the centre one, p_2 , to earth. The line-circuit thus passes from the right-hand block, through the silk-covered wire and the left-hand block, to the apparatus. If a current of dangerously high potential passes from the line to the lightning protector, it must pass through the silk-covered wire, which

it will melt, or heat so as to destroy the silk covering, thus passing to M , and thence to earth; the circuit of the apparatus will therefore be broken by the melting of the wire, or diverted to earth, and in either case the apparatus itself is secured against damage.

When the protector has acted in this way, and consequently broken down the circuit, working conditions may be restored by simply removing the bobbin. When in position the disc a at the end of m_2 lifts the spring C by means of the ebonite block b , so that the platinum contact upon C is clear of p_3 , but on the removal of the bobbin, p_1 and p_3 are joined

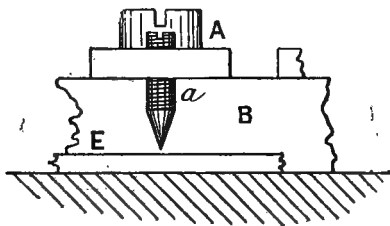

Fig. 79. Full size.

across by the spring C , and the circuit is restored, but *without* the bobbin-protector. There is, however, a protector of the toothed form at F , which prevents the circuit from being absolutely unprotected in any case. If a new bobbin be now inserted, the disc a again raises the spring C , and places the protecting wire of the new bobbin in circuit.

A very simple form of protector introduced in the South Wales District of the Postal Telegraph Department is shown in fig. 79. Upon a wood strip B fixed upon the test-board are mounted line-plates A fitted with two connection-screws—one for the line and the

other for the instrument connection. The ends of these plates project over the edge of the strip, and in them are fixed conical-pointed screws *a*, which can be accurately adjusted very close to a continuous earth-strip *E*. It is found to serve its purpose extremely well.

III.—BATTERIES.

The time for which a telephone is in actual use during any period is, under ordinary circumstances, comparatively short; so that it is very desirable to use a battery in which no action takes place when it is idle:

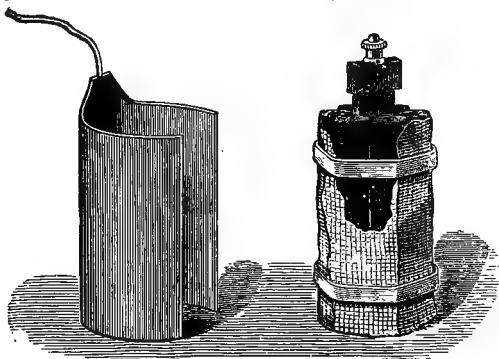

Fig. 80.

and for this reason the Leclanché battery has almost universally commended itself. For ringing purposes when a magneto generator is not used, a small-size porous-cell form is sufficient, but for the microphone-circuit battery (usually two cells), it is advisable to have the large size, or, better still, the six-block agglomerate form. This consists of a grooved cylinder of carbon surrounded by six cylindrical blocks of an agglomerate of carbon (55 parts), manganic peroxide (40 parts), and gum-lac resin (5

parts). The blocks are wrapped with a piece of canvas and kept together by rubber bands (fig. 80). The zinc element almost entirely surrounds the carbon combination. The two parts are shown separate in the figure for the sake of clearness, and for the same reason part of the canvas is removed. The resistance of this cell is almost inappreciable, which constitutes its peculiar fitness for the microphone circuit, inasmuch as it is specially desirable that the whole resistance of that circuit should, as far as possible, be the variable microphonic resistance.

An improved form of Leclanché battery—the Leclanché-Barbier—is very extensively used in France and other Continental countries. Its most important feature is the use of a specially-prepared salt, which, it is said, does not crystallise upon the zinc, nor does the zinc get destroyed unequally. It is made in both “wet” and “dry” forms.

The so-called “dry” cells are coming rapidly into favour for telephone purposes.

Where a telephone is in constant use, it is often necessary to have a reversing switch, by means of which either of two sets of speaking-cells can be brought into use in turn.

In some cases, as, for example, at the London end of the London-Paris telephone lines, secondary cells are being used with great advantage.

IV.—MAGNETO GENERATORS.

Magnetic call-signals are very much used for telephonic purposes. They doubtless furnish a very convenient source of electric energy; but some administrations, considering that the adoption of the microphonic

transmitter in any case necessitates the employment of a battery, and for other reasons, have not adopted them.

The first form of these machines was similar to an ordinary medical magneto-electric machine, but this was soon superseded by the Siemens armature, which has since been adopted by all manufacturers. A general view of the form that the magneto generator now usually

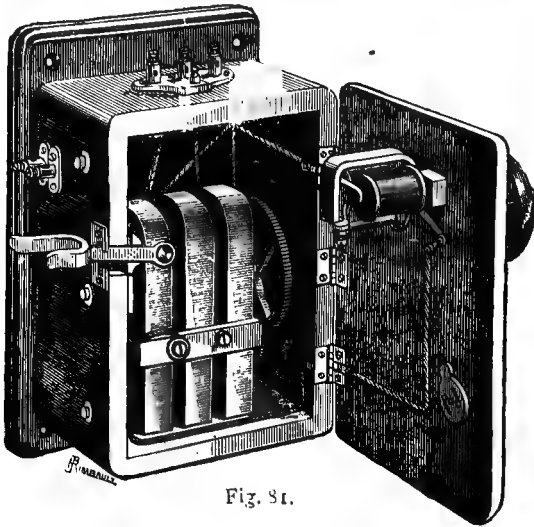

Fig. 81.

takes is given in fig. 81, which represents the generator and magneto bell manufactured by the Consolidated Telephone Company. Figs. 82 and 83 give respectively a longitudinal section and a transverse section from the left of the armature-box of the magneto portion of the same instrument.

The building-up of the armature-box in this instrument is specially simple and ingenious. The two pole-pieces N, S (fig. 83) and the left-hand bearing for the

armature-axle are cast together by means of lead (*l*) into the form of a rectangular box. Three strong permanent magnets (*M*, figs. 82 and 83) are then clamped in position, with their similar poles juxtaposed, by means of clamping strips (*C*, fig. 83). It is important that the magnets fit closely on the pole-pieces.

It will be seen that the inner surfaces of the pole-pieces are curved. These curves are carefully and

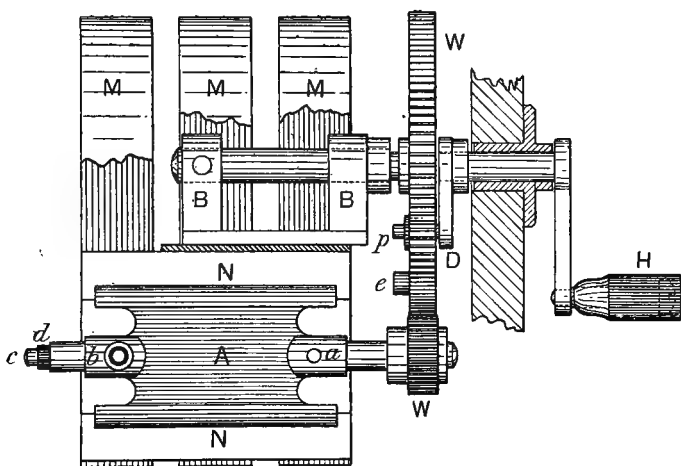

Fig. 82. $\frac{1}{2}$ full size.

accurately turned, so as to ensure that as the armature *A* is revolved it shall be quite free and yet as close as possible to the pole-pieces.

The armature *A* (figs. 82 and 83) is practically an electro-magnet the core of which consists of a soft-iron cylinder, deeply and widely grooved on two sides and at each end, so leaving a comparatively thin web

over which the wire is to be wound. It is, however, really a casting, and at each end of the web is cast a cylindrical extension from which the pivots are formed. The core of the armature *A* must be of the softest iron; its cylindrical surface must be worked most carefully, and the whole centred as accurately as possible in its bearings. The wire is wound over the web on each side of the axis. One end of the coil is soldered to a pin *a*, which is in direct connection with the metallic mass of the armature, and the other end is soldered to the pin *b*, which is insulated from the shaft of the armature

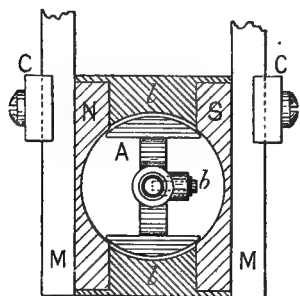

Fig. 83. $\frac{1}{2}$ full size.

and is in metallic connection with the pin *c*, also insulated from the shaft by the ebonite tube *d*. In the machine in question the resistance is about 500 ohms, but in other types the resistance ranges up to 1,000 hms.

At the right-hand end of the armature-axle is fixed a toothed wheel *W*. This wheel gears with the larger driving-wheel w_1 , and, in order to secure quiet running the wheel *W* is made of raw hide, which has been proved very durable for such purposes. w_1 runs in bearings *B*, fixed on the top of the armature-box, between the legs of the permanent magnets. The driving-wheel is actuated by the crank-handle *H*, through the pin *p*, projecting from the intermediary arm *D*. This forms an automatic arrangement by which the magneto coil is short-circuited when not in use, as its presence in the ringing circuit is objectionable. The act of turning the crank-handle breaks the short-circuit. The particular

form of *automatic cut-out* illustrated is known as the *Gilliland*. Through the bearing of the crank-handle the pin p is connected to that end of the coil that is joined to the pin b , while the wheel w_1 , being axled on the armature-box, is connected with the uninsulated end of the coil which comes to a . The pin p projects through a hole in w_1 , and is held against the edge of the hole by means of a spring between it and the insulated stud e ; but when the handle is turned so as to make p drive the wheel, the pin must first move forward against an ebonite bushing in the hole in w_1 , thereby bringing the coil in circuit.

An objection to this form of cut-out is that its action depends upon the handle being turned in the right direction. In the *Williams* magneto the short-circuit is broken by a pin on the crank-axle sliding up the side of a V-shaped recess in the boss of the driving-wheel, so drawing the end of the axle away from a spring connected to the insulated end of the coil. The pin can slide up either side of the V, so that the direction in which the handle is turned is not material.

A very neat and simple form of automatic cut-out in which centrifugal force is the controlling agent is used in the Ericsson-Bell Company's magneto generators. It is shown diagrammatically in fig. 84. A flat spring fitted with a small weight a is fixed upon the armature-axle, to which, as usual, one end of the coil is connected.

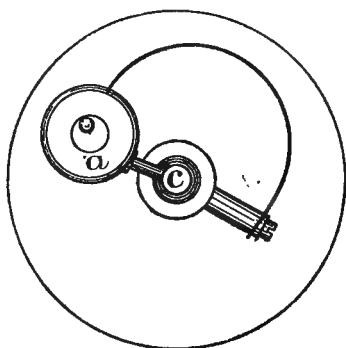

Fig. 84.

The other end of the coil is joined to an insulated central pin, as shown at *c* in fig 82, into which a small contact-pin is screwed (fig. 84). Normally the periphery of *a* is held against this point by the tension of the spring, thus short-circuiting the coil ; but when the armature is rotated the centrifugal action causes *a* to fly off from the contact, and the coil is therefore brought into circuit. The small weight is prevented from receding too far by the stop-pin in its centre. In returning to its normal position a good rubbing contact is made.

A somewhat similar device is introduced in the *Post-pattern* magneto. It consists of a flat spring weighted at its free end, which normally joins across the two ends of the coil. When the armature is turned, the free end of the spring moves outwards by centrifugal force, and thus the coil is kept in circuit so long as the revolution continues.

Friction-gearing and rubber bands for some time largely displaced toothed gearing for the driving of magnetos, owing to the noise made by the latter ; but such great improvements have been made in this respect (especially by the "silent gear" with raw-hide small wheel, as described above), that the undoubted advantages as regards durability, etc., of cut gear are leading to its general re-introduction.

If the crank be turned moderately fast a good machine will actuate a good bell through 20,000 ohms external resistance, although 10,000 ohms is considered ample as a rule.

On the other hand, the bell should be capable of such adjustment that when it will ring with the high resistance in circuit the armature will not stick when the external resistance is reduced to *nil*.

The general connections are shown by fig. 85, in which; however, the Williams automatic cut-out is indicated. It will be seen that the two Bell receivers are shown in multiple circuit, which is generally better than the series arrangement.

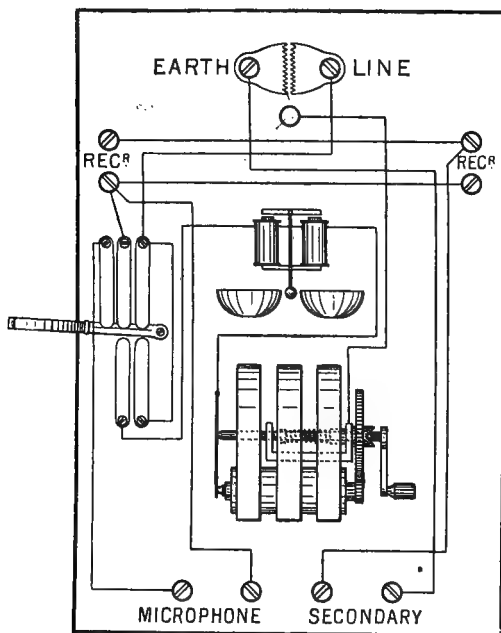

Fig. 85.

The terminal shown beneath the lightning protector is ordinarily connected to "earth," but may be used in connection with a two-way switch for an "extension" bell in cases where an additional bell is required.

Fig. 86 shows a system of connections devised by Mr.

J. J. Carty¹, and now largely used in America. In this arrangement the bells are joined in "bridge" or "leak" between the lines (or between line and earth) at every station, whether terminal or intermediate, and the magneto generator is brought into circuit between the same points (that is, in multiple circuit with the bell coils) by means of an automatic *cut-in*. The lower

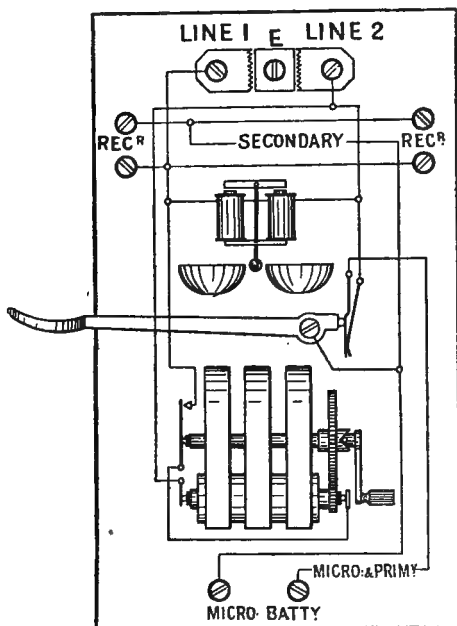

Fig. 86.

contact-springs of the automatic switch-lever are in this case not required. The altered conditions of the circuit necessitate a material alteration in the winding of the armature, as more current is required. Hence these

¹ British Patent Specification 4,794 (1891). Western Electric Company.

generators are wound with thicker wire to a resistance as low as 150 Ω .

This system is said to increase the number of bells which can be placed in circuit to a remarkable extent, and it is probable that its application will become general.

Commutated Magneto.

In some systems the plan is adopted of having two methods of calling—one, say, to actuate the indicators at an exchange by means of alternating currents, and the other to actuate polarised instruments by direct current. It may, of course, even be arranged to have a *third* call by a direct current in the opposite direction. For such a purpose *commutated* magnetos are made. The turning of the handle in the usual way sends alternate currents, but the depression of a button while the handle is being turned sends a current to line in one direction only. In some cases this is effected by connecting the armature coil to line during only half its revolution, so that the alternations are missed and a series of intermittent currents are transmitted, their effect being practically equivalent to a constant current. In other forms the commutation is effected in much the same way as in a dynamo machine, by alternately reversing the connections of the two ends of the coil. Such magnetos are used rather extensively in some American systems, but have not hitherto been adopted in England.

V.—CALL-BELLS.

It is clear that no telephone circuit is complete without a means of calling, and this is usually provided in the form of an electric bell. Such bells may be of different

kinds, according to the requirements of the circuit. The most usual form is

(a.)—*The Trembler Bell.*

This consists of an electro-magnet *E* fitted upon a frame of the general shape shown in fig. 87, which is mounted upon a wooden base. Fixed by means of a spring *S* to the same frame is an armature capable of vibrating in front of the poles of the electro-magnet, and this is extended by a stout wire terminating in a small bell-hammer *H*, the whole being so planted upon the base that the bell-hammer is near to the bell-dome *D*. On the side of the armature opposite to that of the electro-magnet is fitted an insulated adjustable contact-screw *C*, and the spring *S* is so formed that its free end is raised clear of the armature and rests against the point of *C*. The electrical circuit is from terminal *A*,

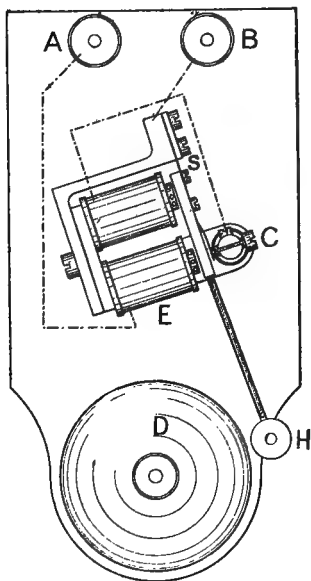

Fig. 87. $\frac{1}{3}$ full size.

through the coils of the electro-magnet to the insulated contact *C* along the spring *S* to the frame, and thence to the other terminal *B*. If now a current pass, the armature will be attracted and the bell-hammer will strike the dome; but this movement will break the circuit at *C*, and the tension of the spring *S* will therefore restore the

armature to its normal position, the circuit will be again complete ; and, if the current be still on, the armature will again be attracted and the bell struck, and so on ; the armature being alternately attracted by the electro-magnet and replaced by the tension of the spring, so causing the bell to be continuously ringing so long as the current is kept on.

Except where the workmanship is thoroughly good and reliable there is some advantage in having the frame extended so as to provide a point of attachment for the bell-dome pillar, as this provides against error in fitting the parts or variation of the relative positions by warping, etc. In most cheap forms of bell the frame is of cast iron, in which case no separate cross-piece for the electro-magnet is used.

In order that trembler bells shall be available for use without relay on direct telephone circuits up to a line-resistance of 200ω , the coils need to be wound to a resistance of 100ω ; but, as this is rather high for a short circuit or in a "local" circuit where a relay is used, the ends of the two coils in the Post Office bells are brought to four small connection-plates under the cover, by which means the coils may be joined in series (100ω) or multiple (25ω).

It will be noticed in the bell illustrated that not only can the contact-screw C be adjusted, but that the pole-pieces on the cores of the electro-magnet are adjustable, being in the form of screws which can be screwed forward or back. This forms a very convenient means of adjusting for sensitiveness.

To produce an effective call, the press-button at the calling station should be kept depressed for a few seconds.

(b.)—Trembler Bell with Indicator.

It is often desirable that a call should not only actuate the bell in connection with the telephone, but should also give indication of the fact that the bell has been rung in case of temporary absence from the room of the person whose duty it is to attend, or, in cases where, more than one bell being fixed, it is desired to indicate certainly which has been actuated.

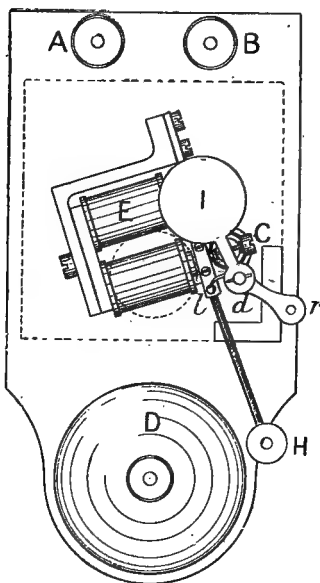

Fig. 88. $\frac{1}{3}$ full size.

Post Office Pattern.—For this purpose the call-bell shown in fig. 88 is often used; it is similar to the previous instrument, but is provided with an indicator. On the armature of the bell is fastened a catch-pin *l*, against which abuts a catch pivoted at *d*. Fitted upon the front end of the same axle as the catch is a light brass arm terminating in a disc *I*, which is painted white, and this disc is so arranged with regard to a circular opening in the front of the case that it is quite clear when the catch is detained by the catch-pin *l*. When, however,

the armature is attracted, the pin moves clear of the arm, which therefore falls by its own weight, and the white disc then appears behind the opening in the case, remaining in that position until it is replaced by pulling a cord attached to the arm *r*.

French Pattern.—The method adopted by the French Telephone Administration is shown by fig. 89. In addition to the ordinary trembler bell parts, an armature a is pivotted at a' , and arranged to move parallel with the ends of the electro-magnet coils E . On the same axle is fitted the arm c , terminating in a detent, which normally holds up the indicator-drop I fixed upon the case of the bell. When, however, a current passes the catch is lifted and the indicator falls. The fitting of the indicator quite independently of the catch appears to be a weak point in this contrivance.

(*c.*)—*Continuous-ringing
Trembler Bells.*

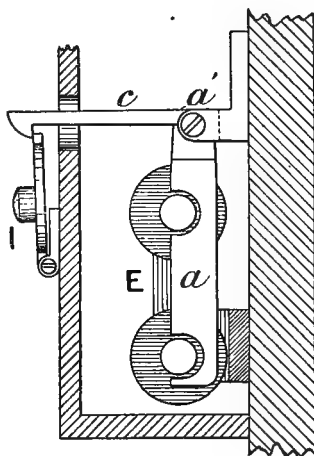

Fig. 89.

The device by which, when once a call has been made, the bell will continue to ring until attention is given, is very similar to that for the indicator. The principle is shown in fig. 90. The incoming current passes from the centre terminal through the coils, etc., to the left-hand terminal, and in so doing releases the detent d , which is pivotted on an extension of the frame, permitting of contact being made by it with c , which is connected to the right-hand terminal. A local battery is joined between the two outside terminals, the circuit of which is completed through the bell so long as the detent

remains down. The detent is replaced by means of a cord on arm *r*.

(d.)—*Extension Trembler Bells.*

Referring again to fig. 90, if there be a battery and another bell joined in circuit between the centre and the right-hand terminals, this second bell will ring as long as the detent is down, but the former only so long as the calling current is kept on the line.

The lever is replaced in its original position, and the second call-bell cut out of the circuit by the cord as before, or sometimes (in this and in the case of the indicator) by means of a mechanical press-button fastened to the base board.

A special switch is generally inserted in the circuit of the second bell, so as to prevent the bell from ringing when not required.

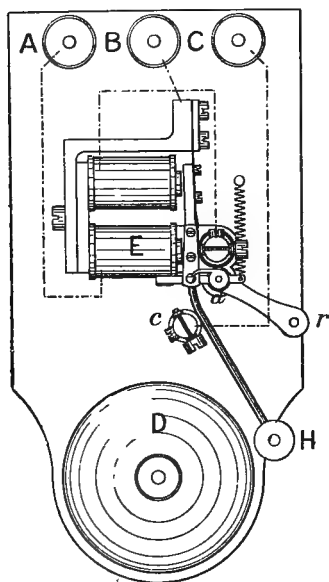

Fig. 90. $\frac{1}{3}$ full size.

(e.)—*Trembler Bells with Automatic Cut-out.*

It is sometimes urged that trembler bells with the ordinary "make and break" suffer from the defect that the contact between the spring and the armature becomes faulty, so that the circuit is thereby disconnected; and also that two call-bells cannot be placed in series on the same

circuit. To obviate these defects call-bells with automatic cut-outs are frequently employed, the action being arranged to short-circuit the coils instead of disconnecting the bell-circuit at the armature-contact. No doubt this arrangement is equally efficient with the other, but it is quite open to question whether it is more so. The inadvertent short-circuiting of the coils is as likely to occur as the unintentional disconnection at the armature-spring; and, as regards the irregular ringing of two bells placed in series, the defect is as marked with short-circuit as with disconnection bells, and for a similar reason—the two bell-hammers are not synchronous. Hence in one case the disconnection of the circuit occurs at one bell before the other has struck, and in the other case the short-circuiting of one (which greatly increases the current) happens before the other, so that each bell has to act with a constantly varying current. The result in either case is irregularity of ringing. The remedy is either to insert relays at both points, or to join the bells on the circuit in “bridge” (p. 158).

(f.)—Other convenient forms of trembler bell are the “*Whittington*” (fig. 91), which is a speciality of the General Electric Company, and the *circular pattern* (fig. 92), which, although it is perhaps in some respects less satisfactory than the more usual form, presents the advantages of being more compact and of working as well in a horizontal as in a vertical position. The illustration is of the form made by the



Fig. 91.

Consolidated Telephone Company, and fitted to many of their complete instruments. The base is a finished brass casting, and the dome is supported on the cross-piece of the electro-magnet.

The call-bells used in telephony vary very greatly in resistance. For direct line working it is generally not desirable to have a very low resistance—a coil of 100^Ω should give a good ring with 20 to 25 milliampères of current. For short or local circuits a lower resist-

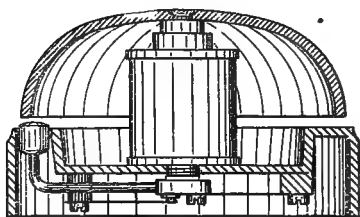

Fig. 92. $\frac{2}{3}$ full size.

ance—say, 25 ohms—will suffice ; but this requires a much greater current.

(g.)—*Magneto Call-bells.*

Where the call is effected by alternating currents from a magneto machine an altogether different type of bell is employed. The general construction is shown in fig. 93. The armature *a*, pivotted centrally in front of the poles of the electro-magnet *e*, is polarised by one pole of the permanent magnet *m*, the other pole of which is brought near or attached to the cross-piece of the electro-magnet. By this arrangement the alternating magneto currents sent through the coils cause the armature *a* to vibrate, thus moving the hammer *h*, which is fixed to the armature, alternately from side to side. On each side is fixed a bell-dome, against which the hammer strikes in its movements. The sensitiveness of the bell largely depends upon the relative positions of the per-

manent magnet, the electro-magnet, and the armature. Either the polarising magnet must not touch the cross-piece of the electro-magnet, or the opposite pole must be an appreciable distance from the armature, depending, of course, upon the strength of the magnet. Otherwise

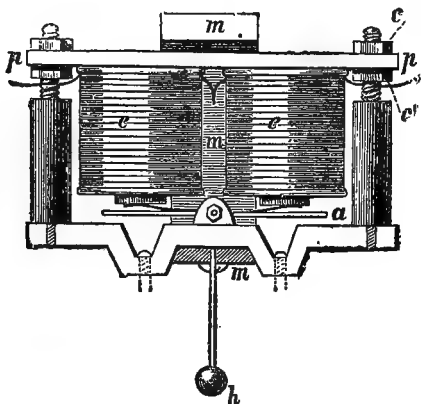

Fig. 93.

the magneto currents cannot easily actuate the armature in opposition to the influence of the permanent magnetism.

VI.—PENDULUM SIGNALLER.

When several offices are placed on one circuit it is often found to be a source of inconvenience and annoyance for every station to receive the call meant for only one—a means of securing an individual call upon such a circuit is therefore very desirable. This is done by means of the device illustrated in figs. 94 and 95, which is the invention of Messrs. Saunders and Brown.¹ Fig. 94 is a front elevation and fig. 95 an elevation of the interior mechanism. The pendulum-rod *p*, which

¹ British Patent Specification 2,020 (April, 1883).

the case.) By adjusting the bob to any one position, and setting the pendulum into vibration, the corresponding station alone is called.

The currents sent to line by the motion of the outer pendulum pass through the coil R inside the case at *every* station. The passing of these currents tends to cause the attraction of the light armature A, to a flexible extension of which is attached the pendulum-rod P', upon which is a bob B'. Now at each station the position of B' upon the rod varies, so that the natural rate of vibration of the inner pendulum at one station alone corresponds with the rate of the outer pendulums when adjusted to one of the marked positions. In all other cases the vibratory attraction of the armature simply shakes the pendulum, but at the one station where the natural rate of oscillation is a direct multiple of the speed of currents transmitted the inner pendulum attains its full amplitude. In doing so the rod P' is brought against the rod r, which projects from the weight w upon the spring S: by this means the short-circuit between S and C' is broken, and either the line-current or a current from the local circuit of a relay can pass through the coils of the call-bell, which are normally short-circuited between S and C'. Thus the bell at the required station is rung, while those at the other stations on the circuit are not.

The pendulum call was first suggested by Bizot, whose system is described by the late Count du Moncel in vol iii. of his *Exposé des Applications de l'Electricité*.

VII.—RELAYS.

Even when they are wound with a large number of turns of wire (to a resistance of 100^ω) ordinary trembler

bells require a comparatively large current — 25 milliamperes being the lowest that can be satisfactorily used. For a long line; therefore, the battery-power required would have to be rather high. This leads to the necessity

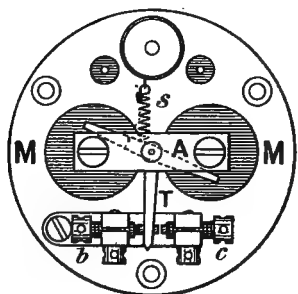

Fig. 96. $\frac{3}{4}$ full size.

of introducing a relay into the circuit in lieu of the bell, and working the bell from the local circuit of the relay.

One form of relay that is used for this purpose is shown, two-thirds full size, in plan by fig. 96, and in side elevation by fig. 97. Mounted on a brass base is an electro-magnet *M*, with projecting cores upon which is fixed a brass cross-piece. Vertically between the coils

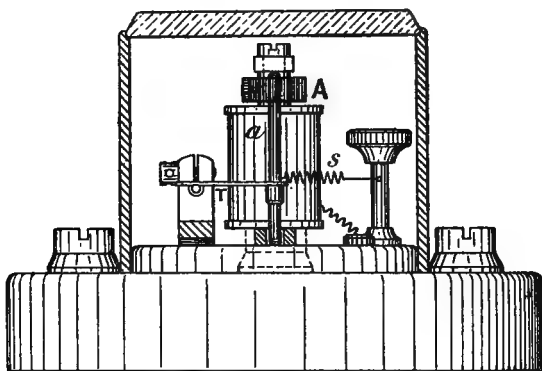

Fig. 97. $\frac{3}{4}$ full size.

is pivotted an axle *a*, upon which at the lower part is fitted the relay tongue *T*, and at the upper end the

armature *A*, the ends of which are situated on opposite sides of the two cores of the electro-magnet. The platinum contact-points at the end of the tongue rest against the end of one of two adjustable screws *b* and *c*. Normally the tension of the spring *s* holds the tongue against *b*, which is fitted with an insulating (ivory) point; but the passing of a current through the coils causes the attraction of the armature and brings the tongue over to contact *c*, thus closing the local circuit of the bell and a battery.

This instrument is often fitted inside the telephone case, but when required separate it is mounted upon a wooden base and fitted with a tubular brass cover with glass top as shown in section in fig. 97.

The current required for this relay, when wound to 100 ohms, is 16 milliampères, so that a reduction of more than one-third of the battery-power is effected by its use. There is, however, a practical objection to the use of a relay if it can be avoided, inasmuch as it forms another piece of apparatus liable to its own peculiar faults and requiring a certain amount of care in adjusting, etc.

VIII.—WALL FITTINGS, ETC.

When it is required to have a telephonic instrument for use upon a table, or in any other position where it is liable to be moved, it becomes necessary to make the connections by means of flexible cords. In such cases the fitting of a "wall-rosette" at the fixed point to which the wires are brought forms a neat mode of connecting the flexible-cord conductors with the

ordinary wires. Figs. 98 and 99 show such rosettes for four and seven wires respectively.

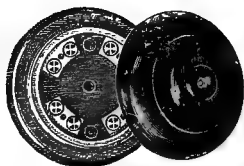

Fig. 98.

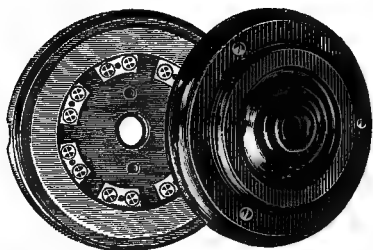

Fig. 99.

If it is desired to have a ready means of transferring a telephone instrument from one room to another, so as to



Fig. 100.

be able to use one instrument at two or more points, the circuits must be formed to the several places and terminated in "wall-blocks." These are so made that a plug with a flexible connection attached can be inserted in a way to complete the circuit of a telephone instrument connected to the other end of the flexible cord. Fig. 100 shows a wall-block and plug for such a purpose. This forms a simple and inexpensive means of making one instrument do duty in two or more places, where, of course, it is not required to communicate from one

point when the instrument is likely to be wanted at another.

CHAPTER IX.

COMPLETE TELEPHONE INSTRUMENTS.

Gower-Bell Telephone.

FIGS. 101 and 102 give views of the Gower-Bell telephone as used by the British Post Office, and fig. 103 shows the ordinary connections.

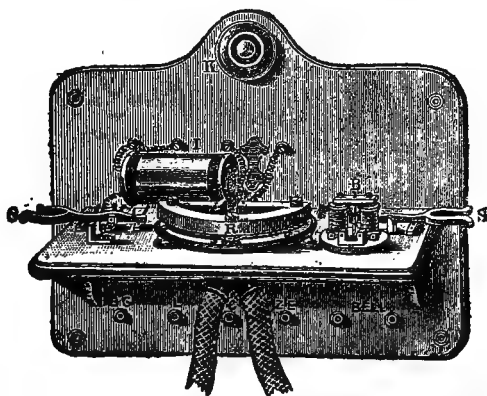

Fig. 101.

The receiver, shown at R in fig. 101, is placed on a separate base beneath the cover, to the underside of the top of which the microphone is fitted. The receiver is of the form shown in fig. 12, with the addition of

three nuts (*a* fig. 103), by which the magnet may be adjusted. The microphone is as shown in fig. 34. The resistance of the primary wire of the induction coil is $\cdot 5^{\circ}$, and that of the secondary wire 250° . Two No. 1 porous-pot Leclanché cells are generally used for speaking, but for busy circuits 6-block agglomerate (fig. 80) are more efficient. The resistance of the receiver is 200° .

In connection with this instrument may be followed out the general principles of the arrangement of the parts of a telephone.

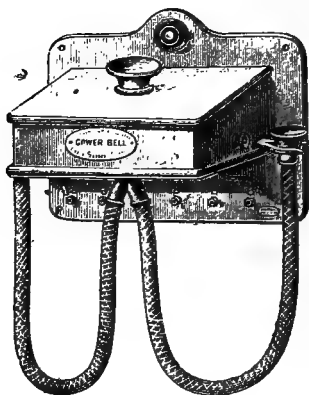

Fig. 102.

K is a small key pivoted (behind the back-board) at its lower end and made to play between two contact-points. The lever itself is connected to line, and the upper contact of the key is connected to one pole of the call-battery, the other pole of which is connected to

earth or to the return line, as the case may be. If now the lever of K be brought into connection with the upper contact by depressing the small ivory press-button at the top of the instrument, a "ringing" current will pass to the line.

The lower contact of K is connected to the axis of the left-hand switch-lever S, the longer end of which, as well as that of the right-hand switch-lever, is normally kept depressed by means of the hearing-tubes, as shown in fig. 102.

If, when this is the case, a current be sent from line, it

will pass, by way of terminal L, key K, switch-lever S, and its front contact, through the coils of the relay B to earth or return line, thus actuating the relay and causing the bell to ring. When this call has been acknowledged by the depression of the ivory button as described above, the hearing-tubes are removed from their positions of rest in the forked ends of the switch-levers S, S', and the speaking and hearing parts of the telephone instrument are switched into circuit. This

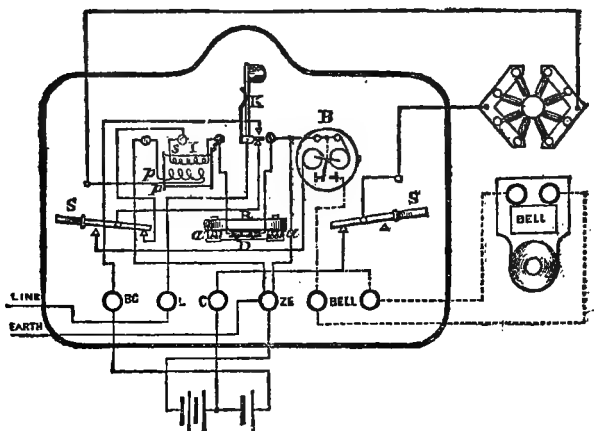

Fig. 103.

practically automatic change of connection is effected by means of two spiral springs, which, on the removal of the hearing tubes, bring the switches S, S' into the positions shown in fig. 103. The right-hand lever joins up the microphone and the primary wire of the induction coil with the left-hand portion of the battery (two Leclanché cells), while the movement of the left-hand lever disconnects the relay from the line and joins in the

telephone receiver and the secondary section of the induction coil.

The Gower-Bell instruments used by the Post Office are now, when returned for repair, being fitted with two double-pole Bell receivers (p. 51), instead of the Gower receiver and tubes. This change, besides improving the instrument (for it has long since been recognised that two hand-receivers are better than the one Gower), effects an actual economy, inasmuch as the tubes—which

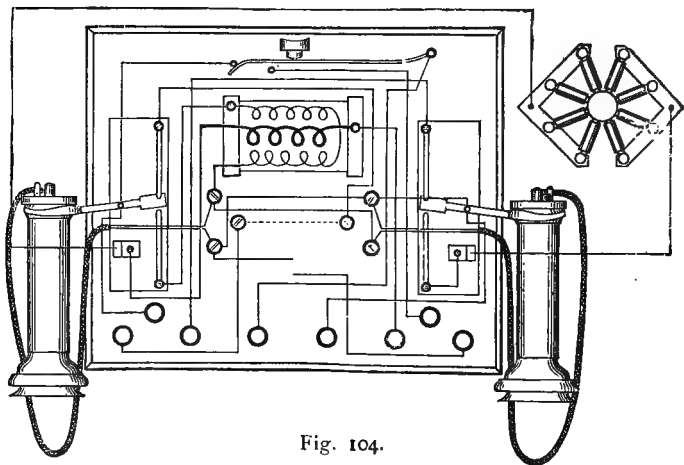

Fig. 104.

are very expensive—require comparatively frequent renewal. By a slight change of the internal connections is obtained the “Universal” telephone, so called because the connections permit of its use, without alteration, under almost every condition of working that is required. These connections are shown by fig. 104, which represents diagrammatically the “Post Office Telephone,” introduced on the expiry of the controlling patents.

It may be remarked that the telephone receivers should invariably be hung with the ear-piece down, as, apart from this direction keeping the ear-pieces free from dust, the receivers when taken in the hands are in the most convenient position for holding to the ears.

The two free wires above the centre terminals are for connection to the local circuit of the relay when one is used. In this case the connection shown by a dotted line is replaced by the coils of the relay (figs. 96 and 103).

There is, as already stated, no essential difference between the general arrangement of the Gower-Bell and any other complete form of microphonic telephone. The differences that do arise do not generally affect the principle. The construction of the microphone, for instance, will, of course, have a direct bearing upon the shape of the instrument, some microphones requiring to be fixed in a vertical, and others in a more or less sloping position ; and, again, it is usual to combine the switches upon one lever. The two separate switch-levers, however, are very useful in some cases as a means of regulating the signals—indeed, for some conditions of the Post Office system they are essential.

Some typical forms of complete instruments may now be illustrated with a few words of explanation to each.

Bell-Blake Telephone.

Fig. 105 shows the complete Bell-Blake magneto combination, which has been the standard pattern of the National Telephone Company. At the upper part is

the magneto generator and bell, fitted with the automatic switch for the Bell receiver. A fixed hook provides for a second receiver, as shown. Beneath is the usual Blake transmitter (p. 71), and at the bottom of the board is a case for holding the microphone-circuit battery, the top of the case being arranged to serve as a desk. Fig. 85 shows the connections.

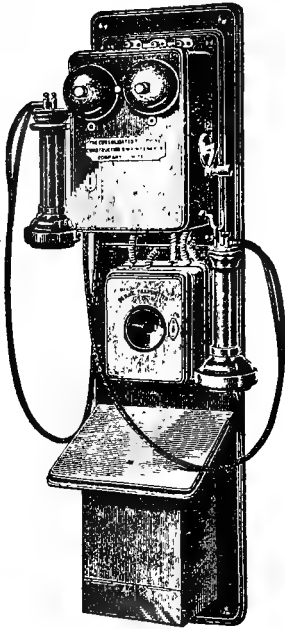

Fig. 105.

Hunning-Bell and Magneto combined.

This is a very compact form, complete in one case, except as regards the microphone battery (fig. 106). The Hunning's transmitter (fig. 62) is fitted upon the door of the magneto-bell case, below the bell, and the induction coil is placed at the back of the case, above the generator. This is a pattern introduced by the

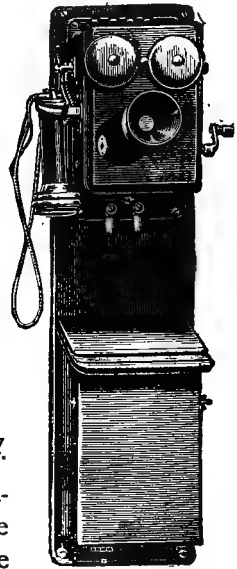

Fig. 106.

Western Electric Company. The connections are shown in fig. 86.

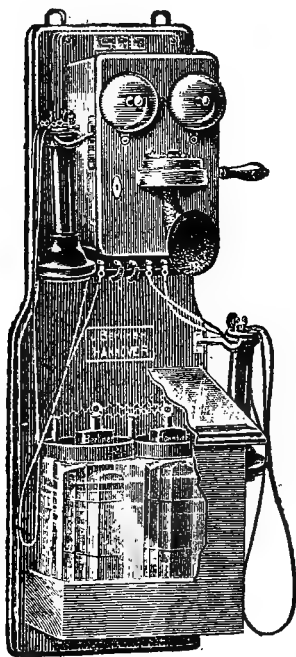

Fig. 107.

tration. (fig. 107) shows it in connection with a magneto set of the ordinary wall-type.

The Ericsson-Bell Wall Telephone.

The general arrangement of this, as shown in fig. 108, will be seen to be very similar to the preceding. The trans-

*Berliner's Universal Set
(Magneto).*

Berliner's transmitter (fig. 59) lends itself very readily to combination with almost any form of instrument. The illus-

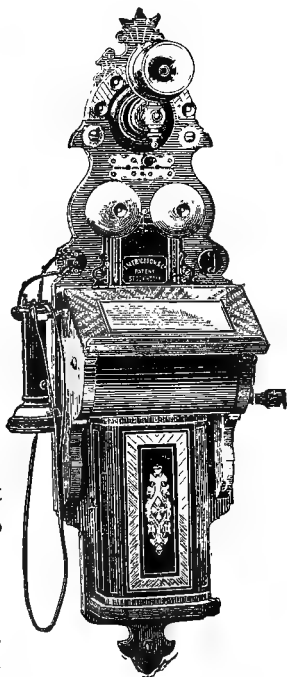

Fig. 108.

mitter, of granular type, is fitted at the top of the board; the lightning protector, just beneath it, is of a characteristic form, provision being made by means of a peg to short-circuit the instrument, to put either line (if the telephone is intermediate) direct to earth, leaving the instrument in circuit on the other line, or to put both lines direct to earth. The top of the generator case furnishes a desk-slope, and upon it is fitted a washable memoranda tablet. A decorated sheet-iron front beneath the generator conceals the microphone battery.

Siemens' Battery-call Wall Telephone.

One of the standard sets adopted by the German Telephone Administration, and manufactured for English use by Messrs. Siemens Bros., is shown—about one-fifth full size—by fig. 109. It comprises a microphone transmitter and two receivers (of the form illustrated by fig. 16) together with a relay, trembler bell, press-button, automatic switch, induction coil, and lightning protector (fig. 78).

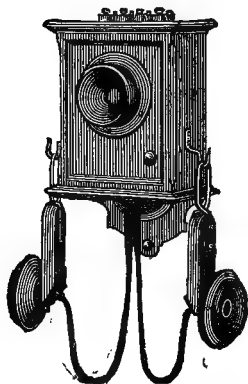

Fig. 109.

Table Telephones.

The extension of the use of the telephone has led to a demand by principals and managers of business houses for an instrument that shall be easily accessible to the user without having to move.

A neat and convenient instrument of this description, manufactured by the Western Electric Company, is shown in fig. 110. The case, which contains the magneto generator and bell, the automatic switch, and the induction coil, may be of walnut, mahogany, or ebonised wood. The transmitter is of the form shown by fig. 62, and is so mounted above the case that it can be turned in any direction, according to the position of the user, irrespective of the base. A double-pole Bell receiver (fig. 21) completes the set.

A very effective table telephone (illustrated by fig. 111) is manufactured by Mix & Genest. The dome of the trembler bell is just visible beneath the base of a decorative standard, within which are the induction coil and the electrical parts of the automatic switch, the hook of which projects for the reception of a watch receiver. The standard is surmounted by a Mix & Genest microphone of the small form shown by fig. 42.

The design of one of the table telephones made by the Ericsson-Bell Company leaves almost nothing to be desired, and the workmanship is also excellent. This instrument is shown by fig. 112. The magneto generator runs very smoothly and quietly. It is provided in some instances with a handle on each side, so that when placed upon a double office table the person on either side can ring without inconvenience. A so-called micro-telephone is employed—transmitter and receiver fitted together as a hand instrument. The transmitter

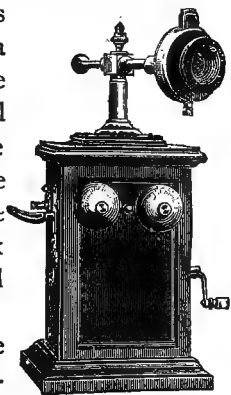

Fig. 110.

is of the granular form, very similar to that shown in fig. 62. The feet of the instrument are fitted with rubber rollers, so that it can be moved easily and noiselessly upon the table.

Fig. 113 illustrates the "Circular Pattern" table telephone manufactured by the Consolidated Company.

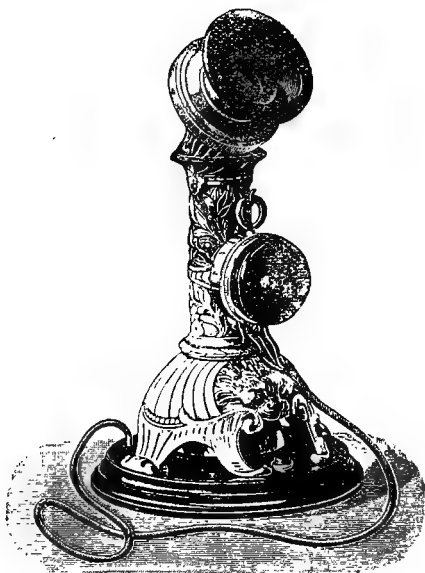

Fig. 113.

A circular box containing the generator forms the base of the instrument, which thereby acquires great stability. A small cylinder mounted above the base upon a brass pillar contains the magneto bell, automatic switch, and induction coil. Two small, neatly-figured bell-domes are fixed at one side, and on the

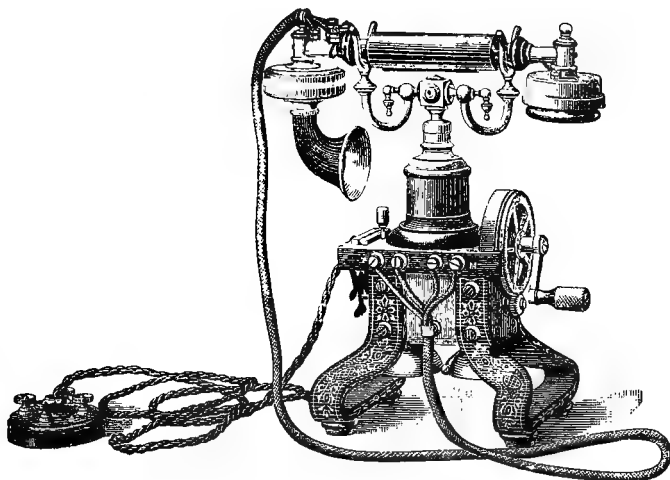

Fig. 112. About $\frac{1}{3}$ real size.

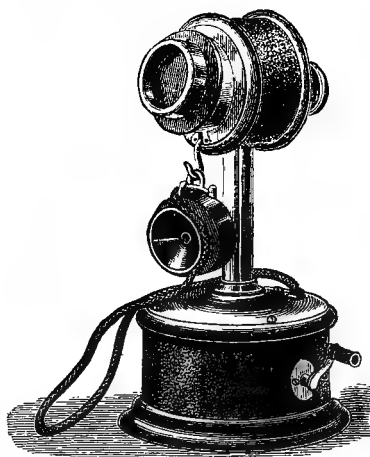

Fig. 113.

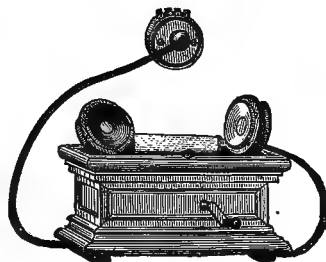

Fig. 114.

other is the transmitter—the “Fitzgerald” granular. A watch receiver is used. The circular boxes are covered with plush, which, as it may be of any required colour, to suit surroundings, gives a pleasing character to a very neat instrument.

One type of table telephone made by Messrs. Siemens Bros. is illustrated by fig. 114. It represents a magneto set, including generator, bell, and micro-telephone, with a flexible-cord connection to a wall-plug. The receiver, as is usual in Siemens’ instruments, is wound to about 200 ohms.



Micro-telephones.

Combined transmitters and receivers, now generally known as *micro-telephones*, are applied to general uses to an increasing extent. Two makes of these have been already illustrated—the Ericsson-Bell in fig. 112, and the Siemens in fig. 114. An example of another pattern—the Western Electric—is given to a larger scale in fig. 115. The receiver is invariably of the “watch” form, differing, of course, considerably as to the magnetic construction; and the transmitter is always some pattern of the Hunning’s type. On the connecting handle is often placed a press-piece, the depression of which joins up the microphone battery

while conversation is going on. It need scarcely be remarked that the micro-telephone is not a complete instrument in itself: it requires

separate induction coil, calling system, and automatic switch. The need for flexible-cord conductors (which have necessarily a comparatively high resistance) in the microphone circuit has a slight tendency to reduce the efficiency of the telephone.

CHAPTER X.

INTERMEDIATE STATIONS.

WHEN more than two stations are in communication upon one circuit, it is often desirable or necessary that the users should be able to divide the circuit at will at one or more points. Thus, if there are three stations, it may be required that when any two are communicating, the third, although still able to signal for attention, shall not be able to interrupt or overhear the conversation of the other two. Again, if there are more than three stations, the circuit should be so arranged that if two at one end of the circuit are in communication, it shall not prevent two others, both nearer the other end, from speaking also.

This is effected by means of "intermediate" switches, which are of various forms.

(a.)—*The British Post Office System.*

In connection with this, attention must be drawn to the fact that under this system metallic circuits are the rule and single wires the exception. In these circumstances there are three distinct ways in which a telephone can be placed intermediate.

(1.) It can be placed in one of the lines, as shown by 'ordinary' in fig. 116. The objection to this arrangement is that the inductive balance of the metallic loop is disturbed owing to the want of electrical symmetry between the two lines, and thus noises from induction are introduced.

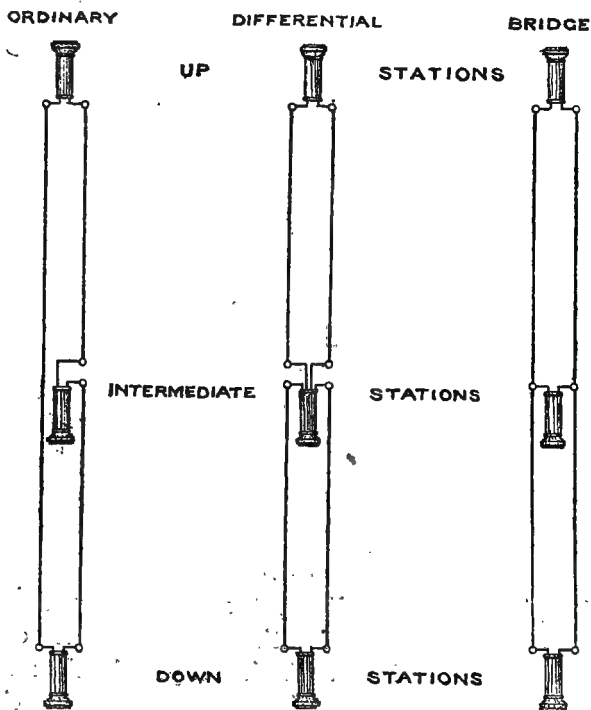

Fig. 116.

(2.) One part of the receiver coils and of the secondary section of the induction coil may be in one line, and a corresponding part in the other line. This plan is fairly satisfactory telephonically, but, as it necessitates

double-winding of the receivers and induction coils, certain electrical and mechanical objections are very liable to arise. The principle is shown at 'differential' in fig. 116.

(3.) Each line may be continuous through the intermediate station, and its instrument joined across or "in bridge," as shown to the right in fig. 116. This arrangement is quite satisfactory from a telephonic point of view, even when eight or ten telephones are placed "in bridge" (if the distance between each is not excessive). The electrical difficulties are very easily overcome by means of properly proportioned fixed resistance

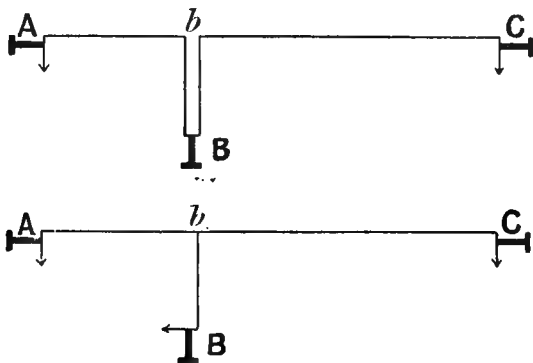

Fig. 117.

coils placed in the different sections of the circuit. The electro-magnetic inertia or impedance of the apparatus itself is here utilised. It permits the receiver to act, but at the same time it so chokes the circuit across the bridge that a large proportion of the working currents passes along the line.

Precisely the same principle applies also to single-wire circuits, only in that case the intermediate station becomes a "leak" to earth.

There is a further advantage which this plan often presents, and that is an actual saving in the erection of lines. This may be illustrated by fig. 117 in which the upper diagram shows the series arrangement of a single-wire circuit, while the lower shows the same stations joined on the "leak" principle. It will be seen that in the latter case only half the wire and insulators between *b* and B will be wanted as compared with the series plan. This economy, however, cannot be effected if a switch is to be used at the intermediate station.

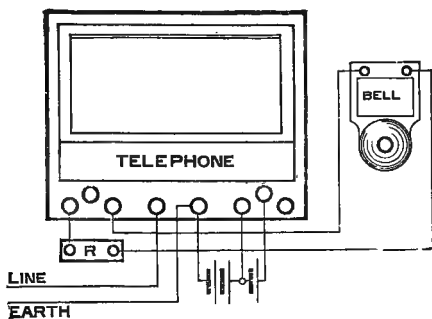

Fig. 118.

There are also other advantages incidental to the bridge system. For instance, a fault in an intermediate instrument (unless it be a short-circuit of the two lines) will not break down the whole line.

The total resistance of the circuit from any ringing-point is reduced (generally very considerably), so that even for the increased current a lower ringing-power is needed. The cost of maintenance of the battery, therefore, is much the same as for the ordinary system, but the reduction in batteries fitted at subscribers' offices is a clear advantage.

The general principles that need attention in connection with "bridge" and "leak" working will be clear from the following general description of the Post Office practice in this respect.

As the current divides in inverse ratio to the resistance, it is desirable, for ringing purposes, that the several arms of a circuit shall not be very unequal. In the case of a "three-office" circuit, balancing resistances should be inserted if necessary in both the shorter branches. The resistance coils should be so connected as to be out of circuit both for *speaking*

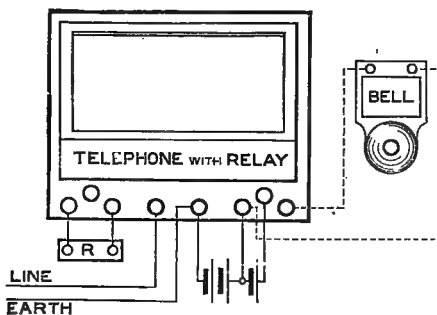

Fig. 119.

and for the *outgoing ringing current*. Fig. 118 shows how this is done for the case where a bell is used direct in circuit, and fig. 119 where a relay is fitted inside the telephone. The advantage of this arrangement is that the introduced resistances do not involve any increase of battery-power, although the ringing currents received by each office from either of the others are practically equalised. These two figures illustrate one of the ways in which the "universal" system of telephone connections is of value (p. 146).

Where there are more than three offices upon a circuit:—

(a.) If the resistance between any one office and the next is small (say, not more than 20^{ω}) no balancing resistances need be used, and bells will suffice.

(b.) If the resistance between the two or more intermediate offices is small and the resistance of one or more of the terminal arms is considerable, then *all* the terminal arms should be balanced, so that each has approximately the same resistance. It should be borne in mind that on the “bridge” or “leak” system, the *second* office at each end is practically terminal, as well as the first, and must not for the purposes of this rule be considered “intermediate.” Thus, *all* offices on a

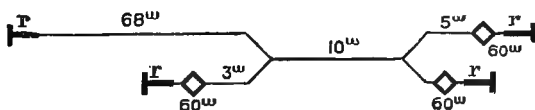

Fig. 120.

circuit with four instruments are “terminal” (fig. 120). The small squares in this figure indicate the balancing resistances required in this case at three out of the four offices. $\frac{R}{1}$ is the symbol employed to indicate that a 100^{ω} relay is used with the telephone; and $\frac{R}{1000}$ (fig. 121) shows that a relay of $1,000^{\omega}$ is fitted.

(c.) When the resistance between the intermediate offices exceeds 50^{ω} , so that it must be taken into account, it is necessary to use a high-resistance ($1,000^{\omega}$ relay at each office. The line-resistances of an ordinary telephone circuit are generally so small in comparison with $1,000^{\omega}$ that they need not be taken into account when this relay is used; and, as the relay is made more sensitive, so that the working current required is reduced

from 16 milliamperes to 7, the introduction of the high resistance is to some extent compensated.

(d.) If, with $1,000^{\omega}$ relays, the resistance of one terminal arm, in a case where more than three offices are in circuit, should be more than 150^{ω} in excess of that of any other terminal arm, it is advisable to insert balancing resistances until the resistance of each arm of the circuit is within 50^{ω} of the resistance of the arm in question.

The battery-power must be so regulated that each

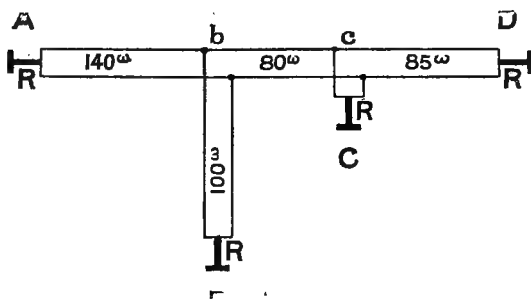

Fig. 121.

office may receive the standard ringing current according to the following scale:—

Bells (100^{ω})	25 milliamperes.
Relays (100^{ω})	16 "
Relays ($1,000^{\omega}$)	7 "

The method of calculating the battery-power required on "bridge" circuits may be illustrated by an example showing the calculation for one station (A) upon a four-office circuit, where relays having a resistance of $1,000^{\omega}$ are used (fig. 121).

$$\text{Joint resistance } c C \text{ and } c D = \frac{1,000 \times 1,085}{1,000 + 1,085} = 520^{\omega}$$

$$\text{Total resistance of arm } b C D = 520^{\omega} + 80^{\omega} = 600^{\omega}$$

$$\text{Joint resistance } b B \text{ and } b C D = \frac{1,100 \times 600}{1,100 + 600} = 388^{\omega}$$

$$\begin{aligned} \text{Total resistance of ringing} \\ \text{circuit from A} \quad \dots = 388^{\omega} + 140^{\omega} = 528^{\omega} \end{aligned}$$

Now, at b the current from A will divide in the ratio of 600 to B and 1,100 to C and D; that is, C and D will get $\frac{11}{17}$ of the current sent from A. Of this, C and D will get respectively in the proportion of 1,085 and 1,000; that is, D will get $\frac{1,000}{2,085}$ of $\frac{11}{17}$ of the current sent from A; and this, for a 1,000 $^{\omega}$ relay of the Post Office telephone type, must be not less than 7 milliampères; therefore, the total current from A must be

$$7 \times \frac{17}{11} \times \frac{2,085}{1,000} = \frac{49,623}{2,200} = 22.5 \text{ milliampères};$$

and (as $E = C R$, and R in this case is 528 $^{\omega}$) the electro-motive force required at A is

$$E = \frac{22.5 \times 528}{1,000} = 11.88 \text{ volts.}$$

It follows that the battery-power at A, assuming the lowest permissible E.M.F. of a Leclanché cell to be 1.2 volt, must be at least 10 Leclanché cells; but, as the resistance of the battery is not taken into account, and the 10 cells do not give much margin, 11 cells might be fixed in this case.

Similar calculations would have to be made to determine the power at B, C, and D; as on the "bridge" system the power required at the several offices generally varies. In the above case the calculations would show that 9, 8, and 9 cells would be required at B, C, and D respectively.

The tediousness of these calculations, and the amount

of time which they take, led one of the authors to devise a scale by which the combined resistances can be read off without calculation. A reduced copy of the scale that is issued to departmental officers by the Post Office is given in the Appendix.

The principle of this scale may be briefly explained thus:—

Let two resistances a and b , which are joined in multiple circuit, be represented linearly (fig. 122) by $A C'$ and $B' C'$ respectively. At B' raise a perpendicular $B' B$ equal to b , and join $A B$. Then a perpen-

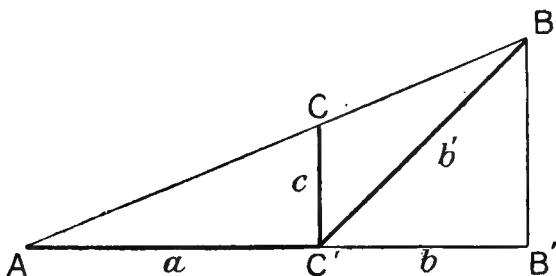

Fig. 122.

dicular c from C' to meet AB will represent on the same linear scale the combined resistance of a and b . Now, it is evident that the point B will always be situated at an angle of 45° with regard to the point C' on the line AB' . The scale is therefore constructed with varying values of a , b , and c upon the lines AC' , $B'C'$, and CC' respectively, C' being the common zero, and the divisions on scale b' bearing the proportion to the true scale b that $B'C'$ bears to $B'B$. The line ACB represents a straight-edge applied to any points A and B on the scales a , b' with the resultant resistance shown on scale c at C .

The "bridge" and "leak" systems are now exclusively adopted in the Post Office Telephone system.

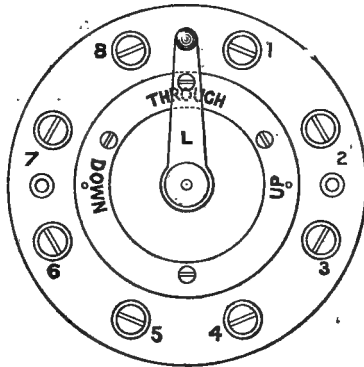

Fig. 123. $\frac{1}{3}$ full size.

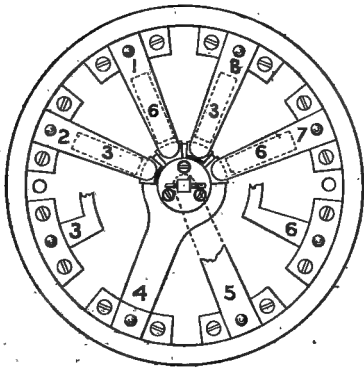

Fig. 124. $\frac{1}{3}$ full size.

The front of the "bridge intermediate switch" that is used is shown by fig. 123, and the back by fig. 124.

1 and 2 are springs which are connected respectively

to "up lines" A and B; 7 and 8 are similar springs joined to the corresponding "down lines." Beneath these springs are brass blocks, connected by brass straps alternately with terminals 3 and 6, as indicated by 3, 6, 3, 6. Terminals 3 and 6 are connected to the terminals of an ordinary trembler bell. The movement

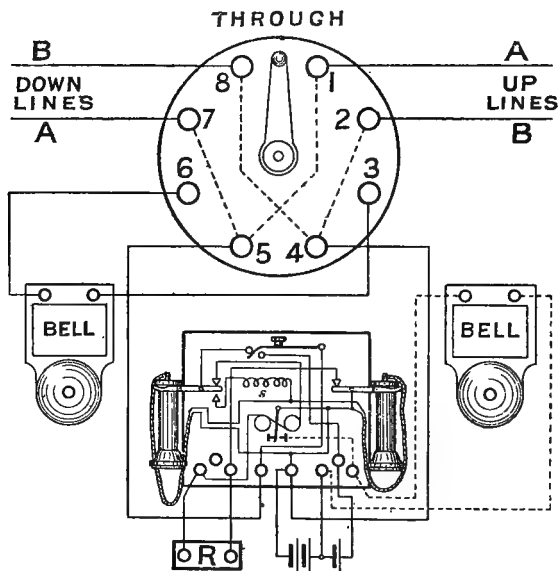

Fig. 125.

of the switch-lever L actuates a cam fixed upon the axis of the lever. This cam is in two sections, which are insulated from each other, and each having two projections; those of the lower section are shown in the figure beneath springs 2 and 8, and those of the upper section beneath 1 and 7. The two sections are connected, by means of the springs shown, to terminals 4 and 5 respectively, which are joined to the two line

terminals of the telephone. The "positions" of the lever are at "DOWN," "THROUGH," and "UP." When the lever is to "THROUGH," all the cam projections are beneath the springs (as shown), lifting them clear of the brass blocks beneath; when the lever is turned to "UP" or "DOWN," one part of each section is beneath 1 and 2 or 7 and 8 respectively, the other two springs falling to their position of rest upon their blocks 6 and 3. It may here be remarked that the four line springs are so constructed that they have a rubbing (cleaning) movement over the blocks beneath them.

Fig. 125 shows the complete electrical arrangement of apparatus at an intermediate switch station under this

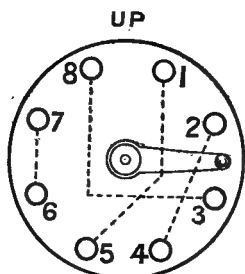

Fig. 126.

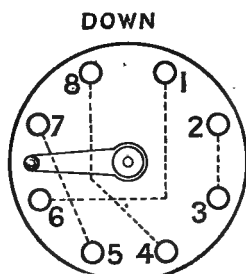

Fig. 127.

system—the dotted lines upon the switch itself showing the internal connections when the lever is in position "THROUGH."

In this position lines A are continuous by way of terminals 1, 5, and 7, and lines B are continuous through 2, 4, and 8; the telephone, with its relay and trembler bell (to the right) being joined between A and B lines respectively at 5 and 4. The extra trembler bell shown at the left is, in this position, disconnected.

When the switch lever is turned to "UP" and "DOWN,"

the connections are changed to those shown in figs. 126 and 127 respectively. In position "DOWN" the connections of the down lines remain to the telephone (5 and 4), but the up lines are now connected to the extra bell (6 and 3). The switch station can then be called by and speak to the down station, but can only be called by the up station through the extra bell. In the "UP" position these conditions are reversed: the up station can both call and be spoken to by the intermediate, while the down station can only call by means of the extra bell.

(b.)—*The German System.*

Fig. 128 shows an intermediate switch used by the German Telephone Administration for single-wire circuits.

There are six flat springs, 1-6, of German silver, disposed around a circular cam, which is capable of being turned within the range of a half-circumference by a lever-handle. Of these springs, 1 and 2 are on a different plane from the others. The switch is intended for fitting inside the case of an intermediate telephone set—the axis of the handle passing through the case from the front.

When the handle is vertical the cam is in the position shown. Springs 1 and 2 are connected through the centre contact-pin, and the other springs are disconnected.

If the handle be turned to the left, the centre pin passes clear of springs 1 and 2, leaving them disconnected, but the movement of the cam secures the connection of springs 3 and 4, and of springs 5 and 6, by means of the four studs *s*. It will be seen that the construction of the cam is as follows:—Around the axis

is an ebonite sleeve, through the forward end of which passes the centre contact-pin, and upon which the springs 1 and 2 press except when the switch is to "intermediate." Around the lower part of the sleeve are disposed two curved brass strips *m*, which are surrounded

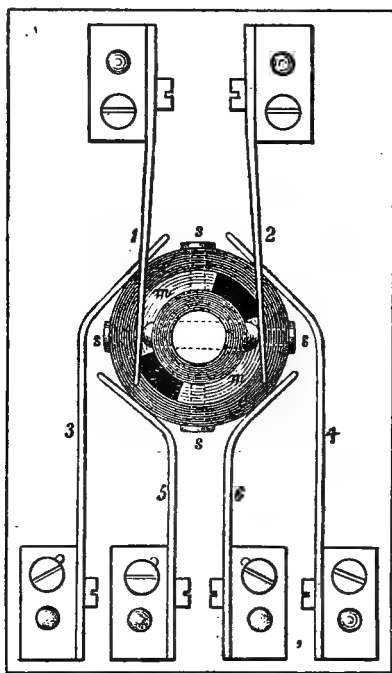

Fig. 128.

by an ebonite ring *e*, to which they are fixed by the four studs *s*. Thus the studs are connected together in pairs, and, as already stated, the turning of the handle to the left secures through the studs the connection of spring 3 to spring 4 and spring 5 to spring 6. Similarly, when the handle is turned through an angle of 45° to the right

the connections are altered to connect springs 3 and 5 and 4 and 6.

Fig. 129 shows the full connections for an intermediate station. Only a magnetic transmitter (p. 42) is shown, but this, of course, does not affect the switch. It will be useful to trace the system of connection through the several positions.

Intermediate Position.—The current arriving from the station connected to L_1 passes by way of the lightning-protector S_1 through the electro-magnet of the relay R , thence, through springs 1 and 2 of the switch, to lightning-protector S_2 , and so by terminal L_2 to line 2.

The terminal stations can communicate, but the intermediate speaking circuit is disconnected.

If in this position the press-button at either of the terminal stations be depressed, the relay R will be actuated, closing the local circuit, and so causing the bell w_2 to ring. By a pre-arranged system of signals the intermediate station can tell which office is being called.

Second Position, handle to left.—The connections are marked in the figure by firm curved lines between the springs; springs 1 and 2 are disconnected.

A current arriving from line 1 passes from L_1 to S_1 , thence through springs 5 and 6, the press-button a , switch-lever v , call-bell w_1 , and to earth.

A current arriving from line 2 by L_2 passes by way of S_2 through springs 4 and 3, call-bell w , and, finally, to earth.

The intermediate station, therefore, can receive a call from either terminal station, and the switch will be turned accordingly.

By depressing a a current can be sent to line 1 from the battery connected to terminal B through springs

6 and 5; and, by the removal of the telephone-receiver from the switch-lever *V*, the speaking circuit is connected to the same line. Thus:—

The intermediate can call the station on line 1, and can speak on that circuit after unhooking the telephone.

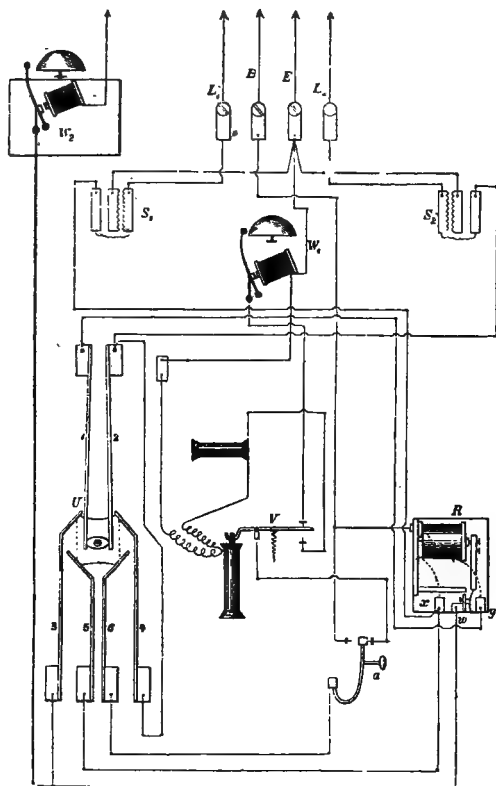

Fig. 129.

Third Position, handle to right.—The connections are shown in the figure by dotted lines. Springs 1 and 2 are disconnected,

The conditions of the second position are reversed. The calling circuit from line 1 is through the call-bell W_2 , and that for line 2 through call-bell W_1 , while the intermediate can call or speak to the station on line 2.

It will be noticed that in this system the relay is not used except when the two lines are through.

(c). *Three-lever Intermediate Switch.*

This (fig. 130) is a useful and reliable form of switch for single-wire circuits, and it has found very general

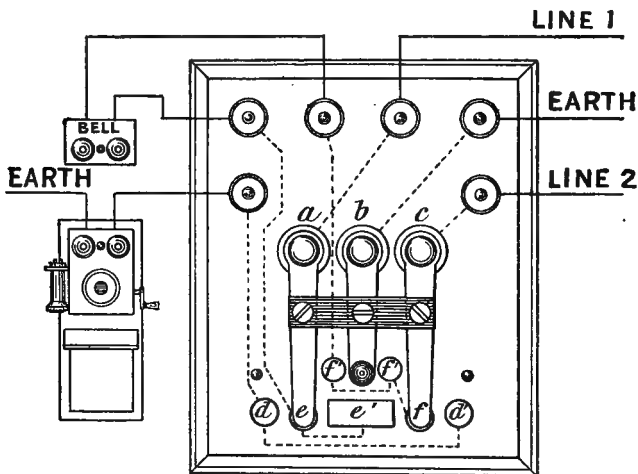

Fig. 130. $\frac{1}{2}$ full size.

acceptance in England. Various foreign and colonial administrations have also used it.

Clamped upon the base of the switch are three springs, *a*, *b*, *c*, of which *b* is fitted with a handle-knob. An ebonite link across the three springs secures that they shall all move together. In the "left," "intermediate," and "right" positions of the handle the

spring *a* makes contact respectively on studs *d, e, e'*, and spring *c* makes contact with *e', f, d'*, while spring *b* is connected to one of the studs *f'*, except when in the intermediate position, where it is disconnected altogether.

The connections can be readily traced. In the position with the handle to the left, line 1 is connected by way of spring *a* and stud *d* to the speaking instrument, while line 2 is joined through spring *c* and stud *e'* to the "extension bell," as separate magneto bells are usually called. These connections are reversed when the handle is turned to the right, line 2 being then connected to the speaking set and line 1 to the extension bell. In the central position as shown, line 1 is joined through spring *a*, stud *e*, and the extension bell to *f*, and thence by way of spring *c* to line 2. The telephone set is disconnected.

Of course, by reversing the positions of the telephone and the extension bell, the speaking set may be in circuit in the intermediate position, if so desired.

(d).—*Miller's Intermediate Switch.*

Miller's intermediate switch, a general view of which is given in fig. 131, has also met with a favourable reception in some quarters. The connections are obtained by a system of springs rubbing upon the periphery of brass segments which form the cam. It is not necessary to detail the various connections.

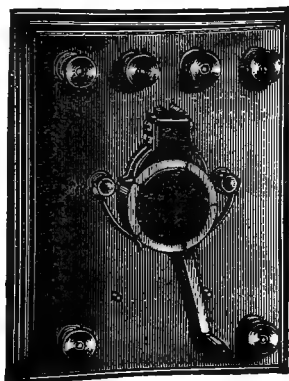

Fig. 131.

The electrical portion

is protected by a cover as indicated by dotted lines. It will be noticed that the contacts are quite independent of moving axles, and are consequently very safe and reliable.

(e.)—*Single-wire "Leak" Intermediate Switches.*

The switches just described, and, indeed, almost any ordinary intermediate switch, will lend itself readily to conversion for "leak" working; but it does not appear that this system has extended sufficiently at present for a suitable switch to be a recognised commercial need. The advantages of "bridge" or "leak" working have been already explained (p. 158), and there can be no doubt that they are now being generally admitted. A much

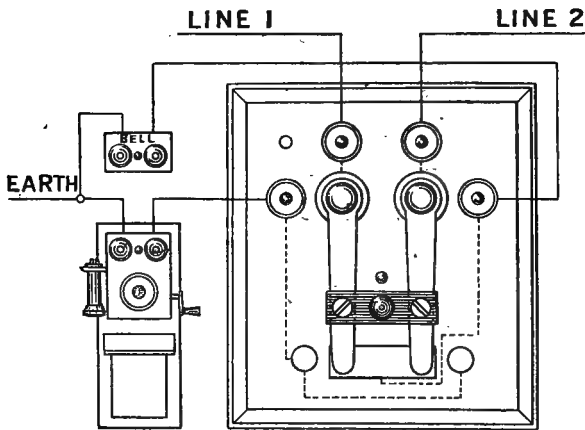

Fig. 132. $\frac{1}{2}$ full size.

simpler switch will suffice, and one on the spring-lever plan, the connections of which will be easily traced, is shown by fig. 132. The handle is in the intermediate position.

A simple form of switch on a plan recently adopted

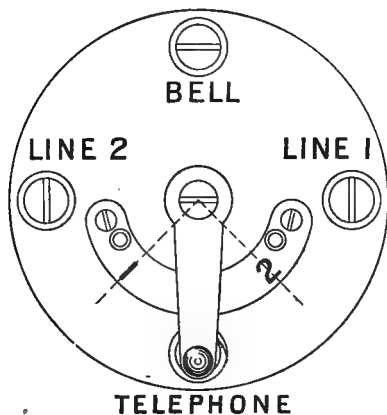

Fig. 133. $\frac{1}{2}$ full size.

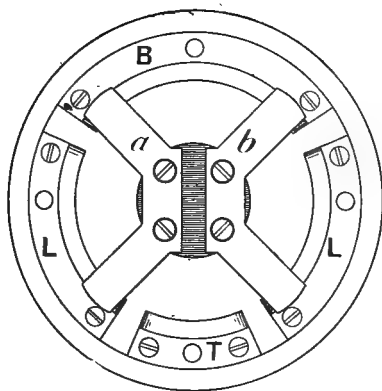

Fig. 134. $\frac{1}{2}$ full size.

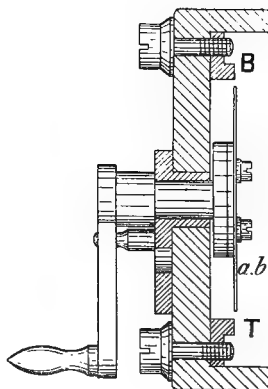

Fig. 135. $\frac{1}{2}$ full size.

by the Post Office is also suggested. It is shown in figs. 133, 134, and 135. The two-arm aluminium-bronze

springs *a* and *b* would move over the projecting ridge on the segments L_1 , B, L_2 , T, so making the required connections.

The advantage of the form of base here indicated (see also figs. 123 and 124) is that the electrical parts are effectually protected.

The external connections of the switch are sufficiently indicated by the lettering of the slot-headed terminal screws in fig. 133.

PART III.
SIMPLE TELEPHONE EXCHANGE
SYSTEMS.

CHAPTER XI.

SWITCHBOARDS FOR SMALL TELEPHONE EXCHANGES.

A SWITCHBOARD is an apparatus by which each subscriber or user of the telephonic system can call and enter into communication with the operator at the exchange, and which enables the connection of any two subscribers to be effected in a quick and reliable manner. For the first-named purpose the switchboard must ordinarily have a separate electro-magnet in circuit with each line, by which a current sent from any subscriber's station shall produce a signal which is easily visible, and, if need be, audible. For the second requirement a variety of different devices have been adopted, some of which will now be described.

All switchboards for use in connection with ordinary small exchanges, whether public or private, may be suitably classed under one of two types: (1) the *Swiss Commutator* plan, or (2) the *American Cord-peg and Spring* plan. For really small exchanges each system presents its own advantages, but for a large number of subscribers the Swiss commutator arrangement becomes unwieldy, and ultimately impracticable.

The original form of the Swiss commutator, which was known telegraphically in England as the "*Um-*

schalter Switch," consisted of numbers of brass bars fitted horizontally above and insulated from another series of bars arranged vertically. At every point of crossing a hole drilled through permitted of the insertion of a brass split plug, thus electrically connecting any of the upper with any of the lower bars. This has proved susceptible of numerous modifications, of which a very good example is the *Chinnock* switch, which has been extensively used, especially in America. Fig. 136

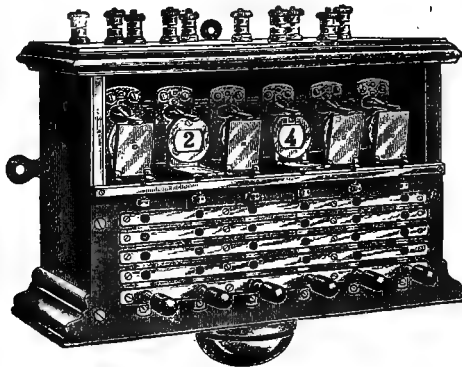

Fig. 136.

shows a complete switch for six subscribers, made on this plan by the Consolidated Telephone Company.

Across the face of the board are fitted horizontally five stout brass strips, drilled with vertical rows of holes beneath the centres of six indicators fitted immediately above the switch. In line with the vertical rows of holes, but behind the board, are fitted thin brass strips clamped in position by thicker strips L (fig. 137). The thin strips are shaped with long projections, which are spaced opposite the vertical rows of holes, and are turned

up to form springs *a*, *b*, *c*, *d*, *e*. These vertical strips are connected through their respective indicators, one to each line. The lowest horizontal strip *E* is joined to earth, so that when the brass plugs are inserted through the holes in that strip as shown in fig. 136, each vertical strip (that is, each line with indicator) is connected through its plug direct to earth. This represents the

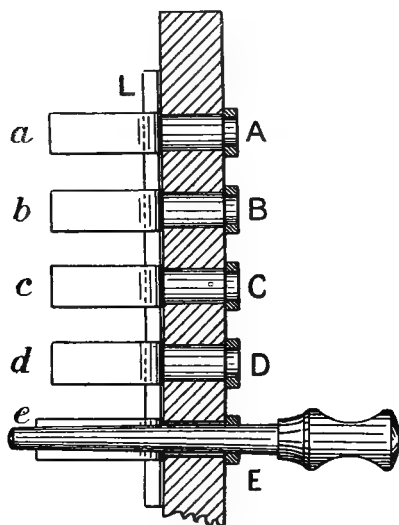

Fig. 137. $\frac{2}{3}$ full size.

normal position. To the next strip, *D*, is joined the speaking instrument in connection with the switch, the other end of which is to earth; thus, when any one of the plugs is inserted in this strip, the corresponding line is joined through its spring *d* to the exchange telephone. Again, in order to put any one line through to any other, it is necessary only to insert the two corresponding plugs in either of the strips *A*, *B*, or *C*.

The indicators shown are known as the Danvers pattern. Above the two coils of an electro-magnet *M* (fig. 138), fitted on an iron L-shaped frame, is pivoted an armature *A*, prolonged beyond its pivots and terminating in a catch. It is held off the poles of the magnet by a flat spring, whose pressure is adjustable by means of screw *s*. Below the catch (which projects through a hole in the vertical arm of the L-shaped frame), and pivoted upon the front plate *G* of the indicator, is a flat plate *P*, which tends to fall to a horizontal position, but is

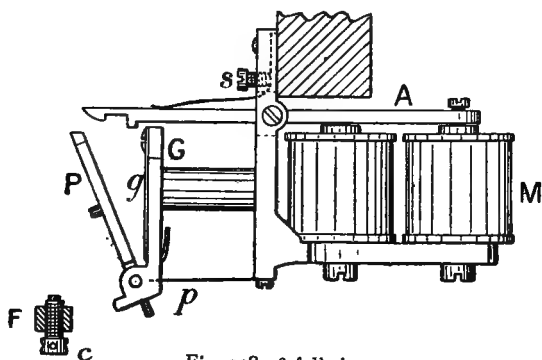

Fig. 138. $\frac{2}{3}$ full size.

normally held up by the catch. The figure shows the armature attracted and the shutter *P* in the act of falling. When it falls it uncovers a number, which is fixed on the front plate *G* beneath a thin brass frame *g*. In this position a platinum point upon the plate *P* rests upon the end of an adjustable contact-screw, *c*, in a brass bar, *F*, which is fixed along the front of the switch just below the indicators. The frames of the indicators themselves are also electrically connected together, and are joined through a trembler bell (shown beneath

the switch in fig. 136) and a two-way switch to one pole of a battery, the other pole of which is connected to F. When, therefore, the two-way switch is closed, if a current passes through one of the electro-magnets M, so that it attracts the armature, the shutter P will be released by the catch, and when it falls to the horizontal position,

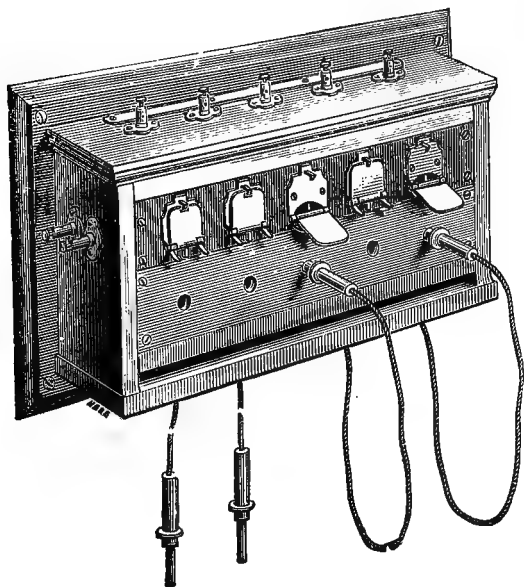

Fig. 139.

resting on F, the local circuit of the bell will be completed, and the bell will ring continuously until the shutter is replaced. When a switch attendant is actually present the falling of the shutter is sufficient to call attention, and the bell-circuit is therefore disconnected by means of the two-way switch.

Good electrical contact for the local circuit between

the shutter and the frame of the indicator is ensured by means of the light spring p fixed on the frame, against which a pin projecting from P makes good rubbing contact when P falls.

As representative of the *Cord-peg and Spring* type of switchboard may be taken the *Spring-jack* system now extensively used by many important administrations.

The Western Electric Company's five-drop Standard

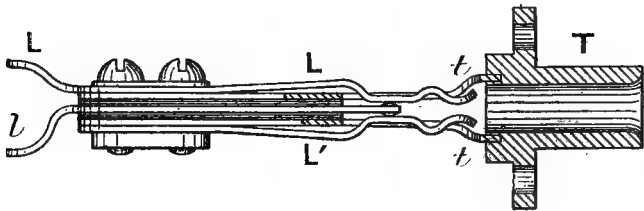

Fig. 140. Full size.

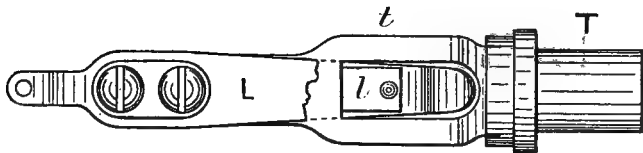

Fig. 141. Full size.

switchboard is shown by fig. 139. In this form the Standard boards are of course suited only to very small exchanges—say, up to 25 lines.

The most recent form of *spring-jack*, or *switch-spring*, used on these boards is shown full size by figs. 140 and 141. The whole spring-block is fixed in position by the insertion of the cylindrical portion T in a circular hole made through the front board of the switch, and fixing it by means of two screws through

the flanged portion. This piece is shown in section in fig. 140. Two flat springs t, t' are soldered into transverse slots at the back of T, and respectively above and below these are placed the springs L, L', the former being provided with a tail-piece; and between t, t' , but insulated from them, is a straight flat spring l , upon which L, L' normally rest; t, t' being gapped, as shown in fig. 141, to admit of this. In fig. 140 the gapped portion of t, t' , is shown in section, so as to clearly show the shape of the two springs L, L'. The



Fig. 142. Full size.



Fig. 143. Full size.

end of l also forms a tail-piece. The whole combination is clamped by means of two screws, which are insulated from l . The cylindrical portion T is bored longitudinally to admit the end C of a peg, shown complete by fig. 142, and with the cover t removed in fig. 143. These are full-sized representations of the smallest peg ordinarily made, which is rather smaller than that used for the ordinary switch-boards. The conductor of a single-wire flexible cord is connected beneath the screw shown in fig. 143. The

cover slides over the body of the peg and is secured by a small screw. The length of C is such that when it is inserted in T (fig. 140) the knob at the extremity passes between the curved ends of springs L, L', thus lifting them from contact with I and joining them electrically with the conductor of the flexible cord.

The form of indicator, or "drop," manufactured by this company is remarkable for its simplicity and compactness. A side sectional elevation is given in fig. 144, which shows the instrument full size. When necessary, indicators of the form shown can be spaced at vertical distances of 1 inch centre to centre, and horizontal distances of $1\frac{3}{8}$ inch.

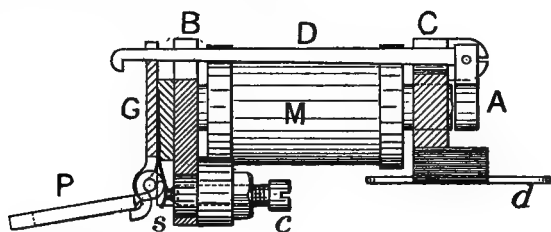

Fig. 144. Full size.

The indicators are made up on strips of soft iron B, of any required length. Upon this strip, for each indicator, are fixed two coils M, for which the strip itself serves as a cross-piece. Clamped over the projecting poles of the cores of M is a brass fitting C, which provides pivot-bearings for the armature A, suspended vertically before the poles. At right angles to the armature is rivetted a long arm D, which terminates in a catch; this arm lies between the coils on the upper side. A brass pin slightly projecting from C prevents sticking of the

armature. Between the front plate G and a somewhat smaller plate behind are clamped a light local-contact spring *s*, and also the hinge-pin of the shutter P. The shutter is held up by the detent on D, the weight of which is sufficient to keep the armature normally away from the cores. When A is attracted and P falls, a tail-piece on the shutter presses *s* against the contact *c*, which is fitted in a large ebonite collet fixed in the iron base B. This forms the local circuit; the whole series of contacts *c* are connected by a wire which is fixed beneath the lock-nut on *c*. Upon the brass fitting C is fixed an ebonite block to which two connection-strips *d*

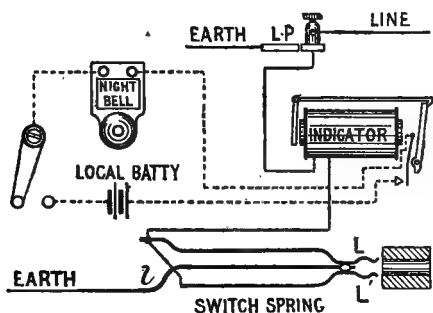

Fig. 145. Connections of a Line on small Standard Switchboard.

are attached. To the inner ends of these strips the ends of the coils are connected, and the outer ends afford a convenient means of making the required connections.

The coils are ordinarily wound to a resistance of about 70^Ω.

Behind the line-terminals at the top of the board (fig. 139) is fitted a lightning-protector earth-strip close to the terminal plates, one edge of which is serrated.

The complete connections for one line are shown in

fig. 145. The operator's complete telephone set (not shown) is connected direct to earth on one side, and to a cord terminating in a single peg on the other, so that by inserting the peg in any switch-hole the operator is properly connected with the corresponding line through the coils of the indicator. The lifting of the springs L , L' from the stud l by the insertion of the peg disconnects earth at that point. Two lines are put through, as shown at 3 and 5 in fig. 139, by the insertion of one of a pair of pegs in each switch-hole, these pairs being at the two ends of a single cord. This leaves both indicators in circuit.

CHAPTER XII.

SWITCHBOARDS FOR ORDINARY PUBLIC EXCHANGES.

SUCH switch boards as those just described are sufficient for a small number of users (say, twenty-five), but when the number of lines brought to a central point is sufficient to keep one or more attendants more or less constantly engaged, the system has to be elaborated in order to facilitate the operation of the switchboard and provide for more rapid manipulation.

The Standard switchboard for one hundred subscribers of the Western Electric Company is shown by fig. 146. If two or more boards are used, auxiliary wires are run between the several boards and joined to the switch-springs below those of the subscribers' lines.

The general disposition of the several parts as shown in the figure is as follows: One hundred subscribers' indicators (fig. 146) are arranged in ten rows of ten at the upper part of the board; immediately below are six rows of twenty switch-springs—five rows of twenty for the hundred indicators, and one row for auxiliary lines. Beneath these again is a row of ten special "ring-off" indicators. Then comes a shelf or table, at the back part of which are ten pairs of pegs, the cords of which pass through holes in the table and are kept straight by weighted pulleys. By this means the two

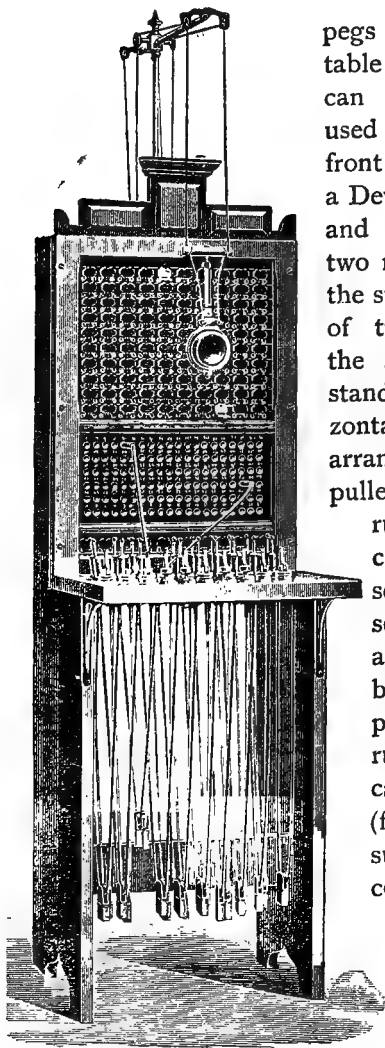

Fig. 146.

pegs rest vertically on the table close together, and so can be easily selected and used by the operator. In front of each pair of pegs is a Dewar or other table-key, and farther forward still are two ringing-keys; or four if the switch is to be in charge of two operators. Above the switchboard is fixed a standard fitted with a horizontal arm, upon which are arranged two series of ebonite pulleys. Over these pulleys run two bare soft flexible copper cords, made up of several strands of six or seven mils wire, and from an ebonite cross-piece between them is suspended by means of a rubber band a neat metal-cased Blake transmitter (fig. 46), for which the suspending wires serve as conductors. The instrument is counterbalanced behind the board, where also the necessary connections are arranged. The transmitter is thus easily adjustable to any

required height, or can be pushed up altogether clear of the board.

Single-wire Standard Switchboard.

The switch-springs are the same as shown in fig. 140.

The connections of a subscriber's line are shown in fig. 147, from which it will be seen that the line is connected direct to the line switch-spring, so that the indicator is cut out of circuit by the insertion of a peg.

Fig. 148, which shows the complete connections of a pair of pegs A, A', with their table-key, etc., will make the manipulation of the switchboard easily understood.

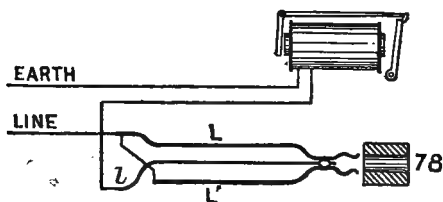

Fig. 147. Line-circuit Connections of Single-wire Standard Switchboard.

The pegs are shown in their normal position, being so held by means of the small pulley-weights p, p' , which run on the peg-cords.

Suppose, now, that subscriber 78 calls; the operator will at once place one of the pegs, A', into switch-hole 78, pull forward the lever of the table-key, and receive the subscriber's instructions. The movement of the table-key puts the springs t, t' in connection with the outer contacts. The circuit is therefore from line 78 through peg A', spring t' , ringing key R', the operator's instrument, key R, spring t , peg A to earth. It will be observed that the earth-connection is secured through

the body of the peg, the end of which rests upon a brass plate connected to earth. The projection of the metal (figs. 142 and 143) beyond the ebonite cover is made in order to effect this. If subscriber 78 requires to be put

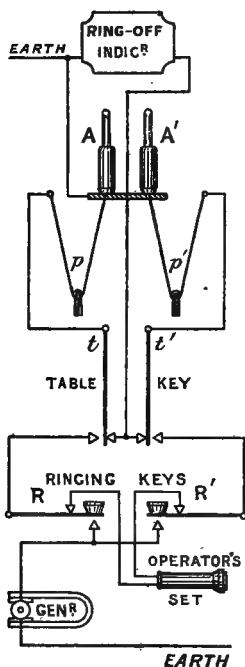

Fig. 148. Peg-circuit Connections of Standard Switchboard with Ring-off Indicator in "leak."

through to (say) 5, the operator next puts the second peg A into switch-hole 5, and depresses the corresponding ringing key, thus sending alternate currents to line 5 from the "generator." On the return of the lever of R to its upper contact, the circuit is from line 5, through t , R, the operator's telephone, R', and t' , to line 78. If subscriber 5 acknowledges the operator's call, the table-key is restored to normal, and the two lines are "through." The circuit is now from line 78, by way of spring t' , through the ring-off indicator to earth; also from t , by way of spring t and peg A, to line 5. Thus the ring-off drop is in "leak" on the through line.

The ring-off indicator is, as already stated, of a special form.

It consists of a single coil (M, fig. 149) wound to a resistance of 1,000 Ω , and constructed on the principle of John Faulkner's altandi electro-magnet, with an iron cylindrical case, F. The impedance of this coil to the passage of telephone currents is such that its presence as a leak on the main circuit does not prac-

tically affect the speaking between the two terminal offices. The other parts of the "ring-off drop" are lettered to correspond with those of fig. 144. The armature A is provided with an adjusting screw, is pivoted in C, which is screwed on the iron case F, and is fitted with the arm D, which terminates in the catch for holding up the shutter. B is the iron strip upon which the whole indicator is mounted, G the pivoting plate beneath which is fitted the local-contact spring (not shown), and P the shutter. The ends of the coil are brought out in the form of two rigid wires through

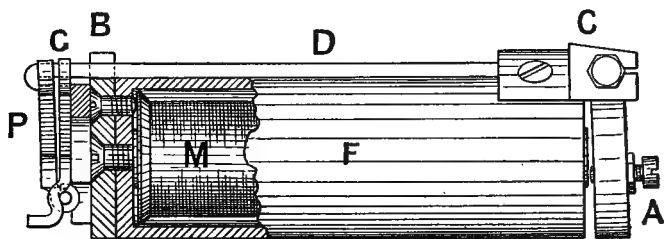

Fig. 149. Full size.

holes in the armature A. On the conclusion of the conversation the subscribers give the ring-off signal (which is a turn or two of their magnetos), the relatively slower alternations of which easily actuate the indicator, and the pegs are withdrawn by the operator.

When a subscriber requires a communication that must be made on another switch, the connection can still be made direct if it be an adjoining switch, but an auxiliary line on the bottom row of switch-holes must be used by arrangement with the operator at any other than an adjoining switch. In such cases it is better that the second operator should put through by means of a

detached pair of pegs, so as not to use an extra set of keys, etc., and introduce another ring-off indicator.

It is quite impossible for one operator to properly attend to so many as 100 subscribers if the exchange system includes a greater number; because, of course, the average number of calls from each subscriber increases with the number of possible correspondents; hence for exchanges which exceed 100 it is necessary to have switchboards fitted for an operator to attend to 50 subscribers instead of 100, as experience shows that to be about the number that one operator can attend to in such circumstances. This question of manipulation will, however, be dealt with later on (p. 206).

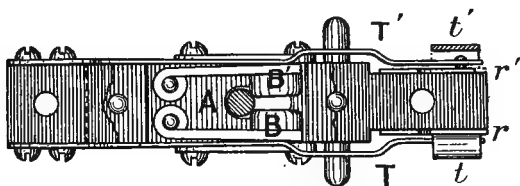

Fig. 150. $\frac{2}{3}$ full size.

The connections of the table-key generally used, which is known as the Dewar table-key, are clearly shown in fig. 148. Figures 150 and 151 show its general construction. It is practically a double two-way switch of compact form, both levers of which are actuated simultaneously, and themselves furnish a locking device for the handle. The whole switch complete is mounted upon a compound ebonite block arranged for fixing beneath the switch-table. The handle-bar A projects through a slot in the table, over which is fixed a slide α , which, as it follows the movement of the handle, covers the slot in both positions. The handle-bar is

pivotted at b , and moves between the two rigid springs T, T' , upon which it acts by the intermediary of the two press-buttons B, B' pivotted in the ebonite base. Normally T, T' are in contact respectively with r, r' , which, although shown as connected together in

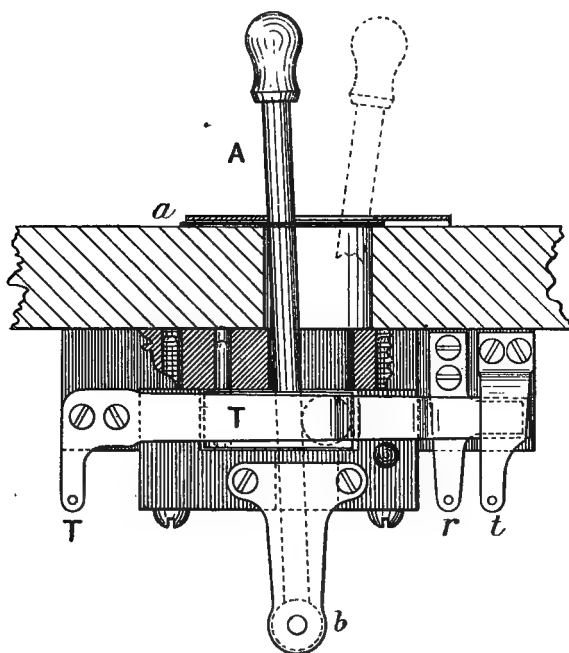

Fig. 151. $\frac{3}{4}$ full size.

fig. 148, are really independent contacts, such being required in some systems of connection. In this position the two buttons B, B' are pressed near together, as shown, by the tension of the two springs T, T' , and so prevent A from being accidentally moved over to the dotted position. When, however, the handle is pulled

over, the bar is forced between the two buttons, and the two springs are brought against the outer contacts t , t' .

The ringing keys are shown in figs. 152 and 153; the former being a plan from beneath and the latter a side sectional-elevation. P is an ebonite press-button, the metal pin of which passes loosely through a hole in the switch-table and rests upon the spring R. A similar press-button acts upon the other spring R'. Normally these springs rest against the upper contacts t , which pass through the ebonite base and are joined to the

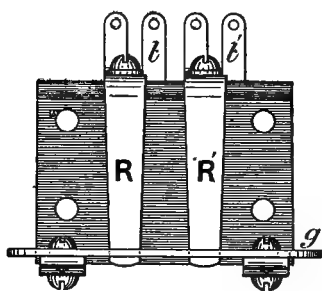

Fig. 152. $\frac{3}{4}$ full size.

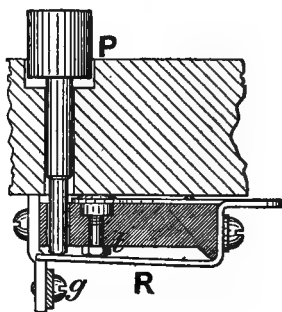

Fig. 153. $\frac{3}{4}$ full size.

connection-strips t , t' . When depressed the springs come in contact with the generator connection-strip g .

The ringing-power for a large exchange is usually obtained from a special *Generator* (fig. 81) kept constantly working by means of a water or other motor. Where such power is not available a *Pole-changer* is used for sending the required alternating currents (fig. 154). At one pole of a strong magnet is pivoted a vertical armature extending into a pendulum-rod. The opposite pole of the permanent magnet is utilised to polarise the cores of an electro-magnet whose poles are brought round on opposite sides of the pendulum near the

armature. Below the electro-magnet are fitted two series of contacts, one of which regulates the oscillations of the pendulum, while the other serves for the reversal of the current. Fig. 155 illustrates the principle of the apparatus. When the pendulum swings to the right, the circuit of the motor-battery B is completed

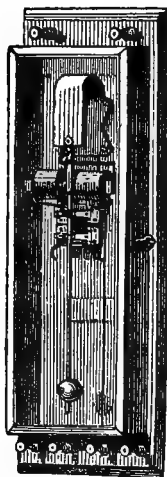

Fig. 154.

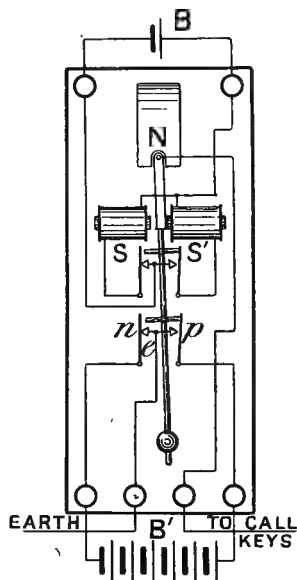

Fig. 155.

through the left-hand coil S of the driving electro-magnet; S therefore attracts the pendulum to the left, and, as a consequence, its circuit is disconnected, and the circuit of S', the right-hand coil, is completed; the pendulum, therefore, is attracted to the right, and again takes up the position represented in the sketch, to continue its oscillations in the manner described. The battery B should consist of two constant cells.

The lower set of contacts acts as follows. The springs n and p are connected respectively to the negative and positive poles of the calling-battery B' : e is a fixed double contact, against the points of which n and p rest when the pendulum swings respectively to the right (as shown) and left, and from which the other spring is disconnected by a contact on the pendulum-rod. Thus these contacts form a reversing arrangement on the battery B' . The double contact is connected to earth, and the pendulum-rod itself is connected to the lower contacts of the calling keys (g , figs. 152 and 153) of the exchange switch. The pendulum is kept in motion so long as attendance is given at the exchange, so that, by means of the pole-changer, alternate call currents can be sent to any of the lines through the calling keys. The battery B' consists of Leclanché cells, whose number depends on the extent of the system.

Ringling over single wires by pole-changers or motor-generators tends to introduce disturbance on neighbouring lines. This, however, is effectually overcome by the adoption of the expedient suggested by Mr. J. D. Miller, in 1889, of putting a small condenser across the generator or pole-changer.

It will be observed that in fig. 148 the operator's instrument is in direct circuit with the two lines that are being put through, although by the final operation the ring-off indicator is in "leak." This appears a scarcely consistent arrangement, and may with advantage be modified as indicated in fig. 156—a modification which presents the further advantage that the earth-connection through the strip upon which the pegs rest is no longer needed.

In the original arrangement of this system each pair of pegs was in connection with separate ringing keys, and the general connections were then as shown by fig. 157. The double table-key was in that case not required, but in its place was a *cam-lever* key. This

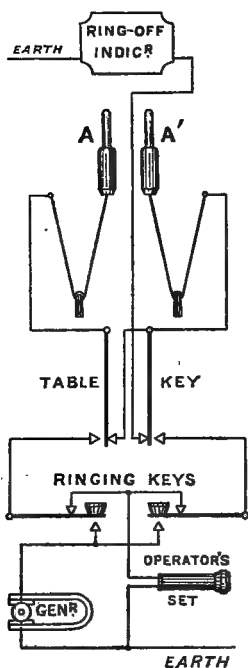

Fig. 156. Peg-circuit Connections of Switchboard with Exchange Apparatus in "leak."

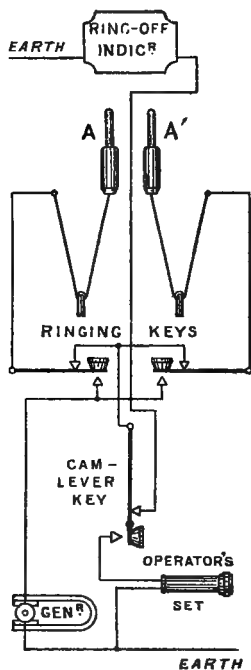

Fig. 157. Earlier system of Peg-circuit Connections requiring two Ringing Keys for each pair of Pegs.

is shown diagrammatically in fig. 157 as a press-key—it was really a lever-switch capable of retaining either position in which it was placed. The general plan of working was otherwise the same, the advantage of the

later system consisting in the reduction of the number of parts. Fig. 157, however, shows the ring-off indicator in leak and not in direct circuit as was originally the case. Of course the 1,000^Ω-resistance indicator would not be suited for insertion in the direct circuit, nor would the smaller form (fig. 144) be right for joining in derivation, as shown in figs. 148, 156, and 157.

Single-cord Switchboards.

To meet the demand for an exchange switch capable of being manipulated with increased rapidity, various devices have been put forward. The most promising method is by the use of boards on which each line is brought to a separate cord and peg, so that practically

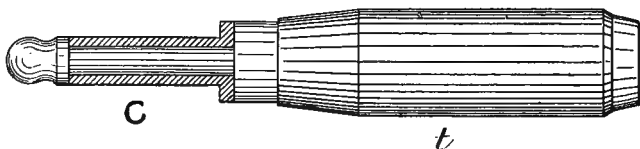

Fig. 158. Full size.

one-half of the required connection is already made. As now constructed, the Western Electric Company's Standard boards are exclusively of this *single-cord* pattern. As their system—which represents the most advanced American practice—is largely followed by other makers, it may now be described.

Each line, as already stated, is connected to a separate peg, first passing through the switch-spring and an indicator. These subscribers' pegs are of the special form shown in fig. 158, from which it will be seen that the cylindrical part C is covered with a sleeve of ebonite (shown in section).

This system also requires that in the switch-block the

line-spring L (fig. 140) shall be separate from the cylindrical fitting T : accordingly two-line switch-springs of the form shown by figs. 159 and 160 are employed. In the particular form illustrated, spring L_1 is longer than spring L_2 , and a good rubbing contact for each upon l_1 and l_2 respectively is secured by giving the latter a slight outward set, which is overcome by the tension of L_1 and L_2 .

The connections for two lines shown by fig. 161, and of the operator's set shown by fig. 162, will make the

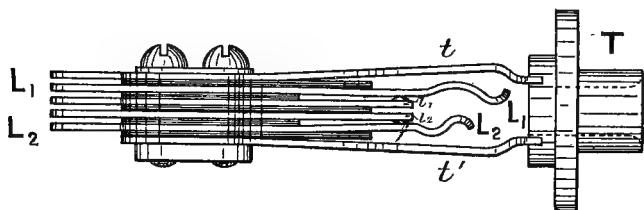

Fig. 159. Full size.

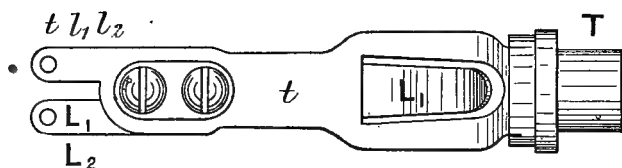

Fig. 160. Full size.

working of this single-cord system easily understood. The operator's special peg is a double one, the tip L'' (fig. 163) being insulated from the main body L' . Provision is thus made for the use of a two-conductor cord.

On the fall of an indicator (No. 27), the operator's instrument is brought into circuit by the insertion of the peg (fig. 162) into subscriber 27's switch-hole. In this case the direct connection between the two line-springs is broken, and the operator's instrument is inserted between

those two points; the tip (*L''* fig. 163) of the peg being connected to the short spring and the main body (*L'*, fig. 163) to the long spring of the switch-block. Simultaneously the subscriber's peg is taken up, so that as soon as his

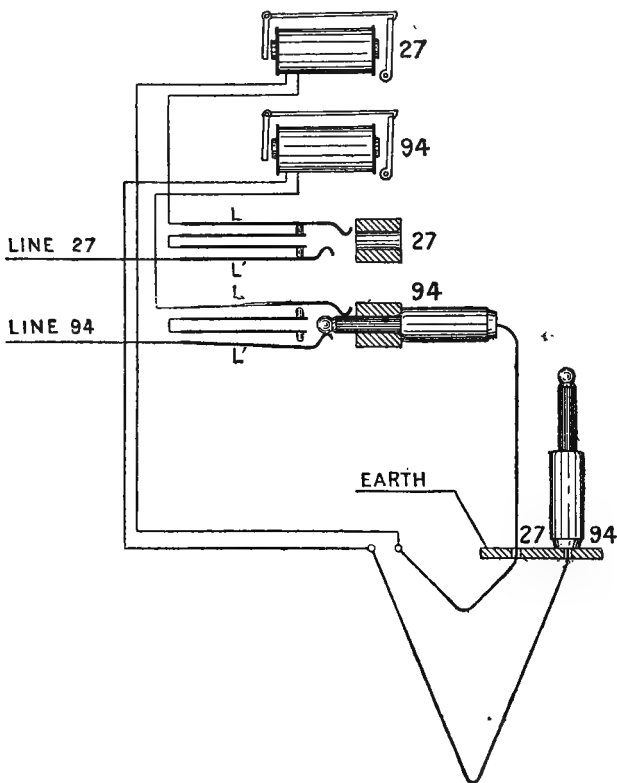

Fig. 161. Single-cord Switch, showing "27" switched through to "94" at the request of the former.

requirement (to be put through to 94) is known, peg 27 is inserted in 94 switch-hole, the operator's table-key is momentarily turned, so ringing both calling and required

subscribers, and, as soon as the reply passes, the operator's peg is removed from 27, leaving the two subscribers "through," as shown in fig. 161.

It will be seen that while the double peg used for the operator's set provides merely for the insertion of the speaking and ringing apparatus into any line, the subscriber's peg with the insulated sleeve serves to disconnect the indicator of the called subscriber. In the "through" position, therefore, only the calling subscriber's indicator is in circuit. It, in fact, becomes the "ring-off indicator," and as it is direct in the line-circuit, it is of the form shown in fig. 144,

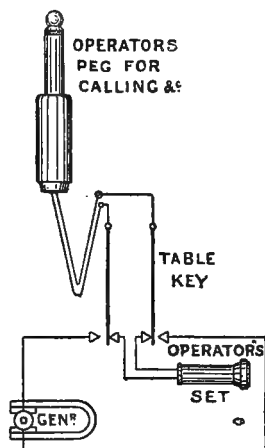

Fig. 162. Single-cord Switch. Operator's Speaking and Ringing Set.

and of low resistance.

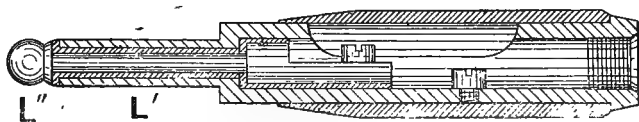

Fig. 163. Full size.

This system consequently does not require separate ring-off indicators.

Double-wire Switchboards.

The foregoing descriptions have had reference to

systems of connections in which a single wire is used for each circuit, but there can be no doubt that for any

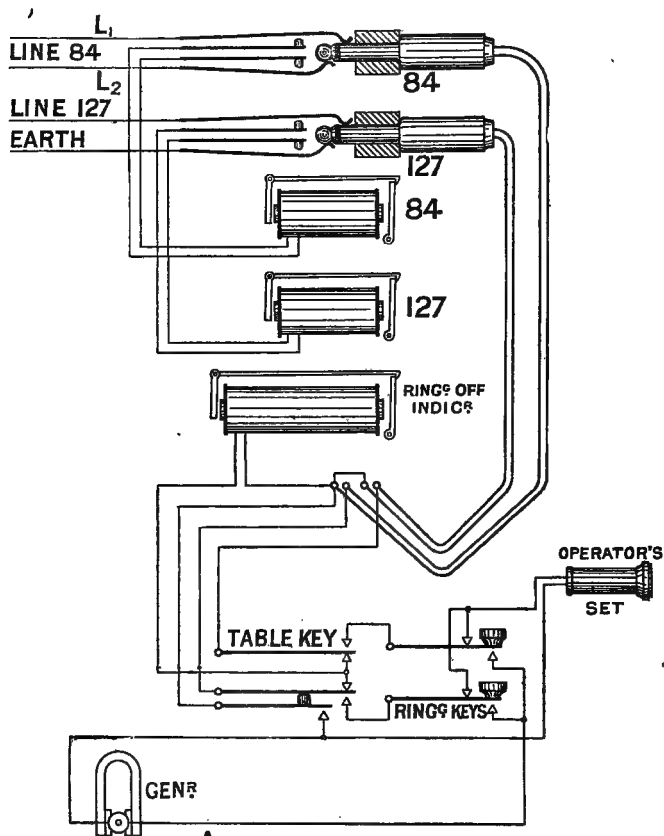

Fig. 164. Connections of Metallic-circuit Switch ; showing also Through Switching on a Mixed System.

large system of telephone circuits double wires are essential for satisfactory working.

One of the most approved forms of spring-block for

two-wire circuits has already been illustrated in connection with the single-cord system (figs. 159 and 160). The connections for such a circuit are shown by "84" in fig. 164. The two line-wires are brought to the springs L_1 , L_2 , the former being also joined to the body of the spring-block through t , and the indicator-coils are connected between L_1 and L_2 .

The two connection-pegs used are the same as that already illustrated (fig. 163), and the general system of working is not modified.

Fig. 165 shows the connections of the pegs, ring-off indicator, etc. The table-key is of the Dewar pattern, with the addition of an extra spring and contact upon one side. This is actuated by the inner spring through a small ebonite stud fixed between them. The other conditions are virtually the same as those already described, the ring-off indicator (fig. 149) and ringing keys (figs. 152 and 153) being of the usual form.

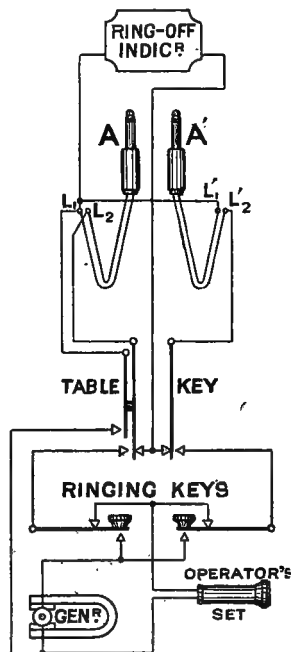

Fig. 165. Peg-connections of a Metallic-circuit Switch.

The extended use of the telephone often leads to the necessity of having certain circuits made double wire, even in exchanges the majority of whose subscribers are not on metallic circuits. Further, it is nothing unusual to find a policy of gradual conversion from single

wire to metallic circuits. In view of such requirements, it is a good plan, if the slight additional expense is not prohibitive, to fit *all* boards for double wires, so that in case of change the switchboards do not need to be disturbed. When this plan is adopted, the earth-connection to the single-wire circuits should preferably be made, not at the switchboard, but in the test-room, at the same point where the second line is brought in for metallic circuits. Fig. 164 shows how upon a mixed system two circuits, one single-wire and the other metallic, may be connected.

Through Switching between Sections.

Reference has been made (p. 194) to the need of special through-connection wires between the different 100-line sections of a Standard board in an exchange with a large number of subscribers. A few notes on these may be suitably introduced at this point.

On the ordinary 100-line boards twenty through-connection holes are usually provided. Now, where the boards are placed in the most convenient method, side by side, an operator at one board can without difficulty use the near half of the next board, so that the operator or operators at (say) board B have direct access without other assistance to 200 switch-holes. The operators at the terminal boards, however, have direct access to the next boards only on one side, giving them 150 switch-holes without other help. It is found in practice that in any case, although direct *switching* between the whole of two neighbouring boards is not possible, verbal communication between the operators is the most convenient method. Further, where the exchange is not too extended, four through connections between each section

are found to suffice, hence the twenty holes at each switch can be apportioned in five groups to five other sections, showing the ultimate capacity of such provision to be 600 subscribers.

Thus, four through-connection holes at each board would be apportioned to each of the other boards and joined to the corresponding holes by wires—namely, those at A would be allotted in groups to B, C, D, E, F; those at B to A, C, D, E, F; those at C to A, B, D, E, F; and so on. If now, subscriber 58 wishes to speak to subscriber 324, the operator at switch A instructs the operator at D to connect A.2 (the other end of the through-connection D.2) and 324. This may be done by a plain pair of pegs, as already explained (p. 193). The operator at A then rings 324, and on receiving a reply completes the required connection by joining subscriber 58. to through connection D.2 in the usual way.

Now, it is clear that the higher the number of subscribers the greater will be the proportion of connections that must be made by the assistance of a second operator, and this will have a very marked effect in increasing the time taken to make the necessary connections between subscribers. In fact, the efficiency of the ordinary system may be said to decrease as the need increases, although, perhaps, not in direct proportion. Mons. de la Touanne¹ has developed a simple mathematical expression, which gives a very clear indication of this effect of the growth of an exchange system. Although it is customary, in all well-regulated exchanges, as far as possible, to group upon the same board those subscribers who are in most frequent communication, the difficulty of doing so increases with increasing numbers, and

¹ "Annales Télégraphiques," 1890.

it is therefore not unfair for the purposes of comparison to assume that the connections required by each group of subscribers will be equally distributed over the several sections.

Suppose, then, that N be the number of 100-line sections; that H be the total number of connections required through the whole exchange in a given time, and that the operators at any one section can give direct communication over one-half of the neighbouring switch on either side.

Now, the number of calls at each board will be $\frac{H}{N}$, $\frac{1}{N}$ of the operations arising from which will have to be completed at each of the other boards. Take first the $\frac{H}{N}$ calls made at boards other than those at each end; then $\frac{H}{N} \cdot \frac{1}{N}$, or $\frac{H}{N^2}$ will be met by connections on the board itself, and an equal number upon the half-sections of the boards on either side. That is to say, at each intermediate section, $\frac{2H}{N^2}$ of the number of calls made will be met without assistance. As there are $N-2$ of such sections, the total number of such connections for them will be $2(N-2)\frac{H}{N^2}$. As regards the two end sections, the direct connections on the sections themselves will be as in the other cases—namely, $\frac{H}{N^2}$; but as the operators at the actual end half-sections have no means of making connections unassisted except upon their own board, the unassisted external connections at each end section will be only $\frac{H}{N} \cdot \frac{1}{2N}$, or $\frac{H}{2N^2}$. The total direct connections made at these two sections will therefore be $2\left(\frac{H}{N^2} + \frac{H}{2N^2}\right) = \frac{3H}{N^2}$. The total number, D , of through connections made direct in such circumstances is, therefore—

$$\frac{H}{N^2} [2(N-2) + 3] = \frac{H}{N^2} (2N-1);$$

or, if the total number of connections required (H) be

made 100, so as to express the number of direct connections in terms per cent., then

$$D = \frac{200N - 100}{N^2}.$$

Now, if this formula be applied to the cases of two exchanges, say of 500 and 1,000 subscribers—that is, where N is respectively 5 and 10—it will be seen that, whereas in the former instance the operators will be able to give the required communications direct for 36 per cent. of the calls, only 19 per cent. will be so met in the second case.

The method of manipulation of these through-connections between the various boards now demands some notice. There are many ways in which these lines may be worked, but the chief point is to secure a system that will involve a minimum loss of time. When the importance of this requirement was less appreciated, the plan adopted was to place an indicator at each end of the through-connection wire, so that the operators could call from either end of every wire. The whole operation in that case would be as follows:—Suppose that subscriber 80 on board A asked for No. 440 (on board E). When the operator at A, by inserting one peg of a pair in switch-hole 80, had ascertained the subscriber's requirement, the second peg of the same pair would be inserted in the switch-hole of (say) through-connection line E.3, and operator E would be called in the same way as an ordinary subscriber. Placing one peg of a pair in through-connection hole 18 of the E board, the operator there would receive A's instructions (or in some cases the calling subscriber's—80), put the second peg in switch-hole 440, and retire, leaving the operator at A or subscriber 80 to complete the call. The ring-off indicators at

both switchboards would remain in circuit, which is of little moment with indicators of high impedance (fig. 149).

A second method of procedure, and one that is more usual, is to have no indicators on the through-connection wires, but to have a special call-wire between each two operators, this wire being fitted with an indicator at each end, and being manipulated merely by a table-key, This is a much more satisfactory plan.

A still more simple and expeditious method can be employed when the operators are constantly listening by means of a "head-gear" telephone. In this case a speaking-wire allotted to one operator's instrument makes the circuit of the switchboards, the operator at any of which can switch into circuit and speak. Taking the same example as before: On receiving the call and instructions from subscriber 80, operator A with one hand puts the second peg of the pair into through-connection hole E.3, and simultaneously switching on to the E call circuit, says, "A.3 to 440," whereupon the operator at E makes the connection, and 440 is called from A. This is by far the quickest method, making probably a difference of no more than five seconds between the completion of a direct communication and one through a second switchboard—about 30 and 35 seconds respectively, assuming that the called subscriber answers promptly.

BENNETT'S "RING-THROUGH" SYSTEM.

In the ordinary systems of switching, some inconvenience is apt to be felt owing to the fact that subscribers, after having been put into communication, cannot ring each other without the signal being mistaken at the exchange for a notification of the termination of their conversation. This leads to great irritation and

loss of time, and is a defect which has consequently attracted the attention of many experts. Several systems have been devised with a view to overcome this drawback, notably by the British Post Office and by Mr. Poole and Mr. Emmot in this country, and by M. Berthon in France, but the plans proposed require the introduction of apparatus not generally used by ordinary telephone companies, so that the consideration of expense militates against their application. The Post Office plan is applicable to the Post Office system almost without the need of addition, but it could not be used on the companies' system. Mr. Bennett has produced an efficient ring-through device which is not subject to any such drawback, the ordinary magnetos and

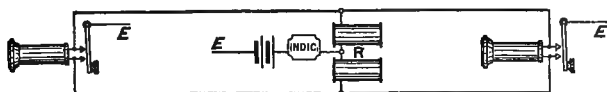

Fig. 166. Principle of "Ring-through" system.

indicators being retained. At the subscriber's office a button or key is provided, which, on being pressed, either earths the metallic loop or connects it to a third or return wire (fig. 166). At the exchange the switch-spring has three contacts so arranged that the indicator may be either short-circuited or disconnected by the insertion of a peg. The connections are shown by fig. 167. Between the conductors of each connecting-cord is a bridge, or shunt, consisting of two equal electro-magnetic resistance coils of 1,000 ohms each, from between which a wire is led to earth (or to a return wire) through an ordinary indicator and a battery, the battery being common to all the pairs of pegs. Thus, when a through connection is made there is a leak to earth at the exchange ; but, as it is through the equal branches of

the bridge, it has no evil effect on the loops. The subscribers can consequently ring each other on the loop without affecting the exchange indicator, whereas when the conversation is finished a momentary touch of the earth-button, or key, of their instruments suffices to close the earth or return circuit, and so drop the indicator. Instead of two resistance coils with an indicator in addition, the indicator itself may be inserted directly in the bridge between the conductors of the cords, but it then must be wound with coils of high resistance connected similarly to the resistance coils, so as to be actuated only when the current from the battery in the

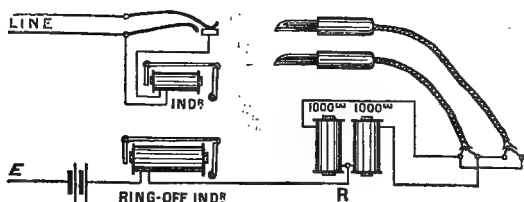

Fig. 167. Exchange Connections on "Ring-through" System.

earth circuit enters the line by splitting between the coils of the electro-magnet. This system is very similar to M. Berthon's, except that the latter used voltaic currents throughout and adopted the earthed circuit for ringing-through and the loop for calling the exchange. This somewhat complicated the keys at the subscriber's, although it correspondingly simplified the exchange connections. With voltaic currents this presents the advantage of reduced resistance for the ringing-through circuit. M. Berthon's system was fully described in "The Telephone," p. 255, *et seq.*, but it is not included in the present work, as its use has been discontinued.

CHAPTER XIII.

THE ENGLISH POST OFFICE SYSTEM.

THE form of switchboard adopted by the English Post

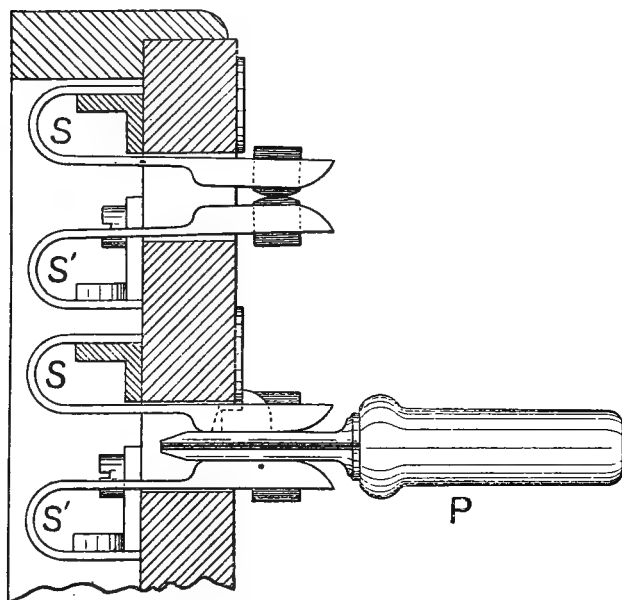

Fig. 168. $\frac{2}{3}$ full size.

Office for ordinary exchanges is shown by fig. 168, which is drawn two-thirds the actual size.

Each hole of the switch includes two brass springs $S S'$, fixed behind a mahogany frame, through which the thick ends of the springs project. These springs have a tendency to close together, but are prevented from doing so by ebonite projections as shown, or by another device which is not shown. The several holes are placed in electrical communication with each other by means of pegs P , which are connected in pairs by flexible cords. The two insulated wires of the flexible cord are connected to the two brass faces C, C' of the peg (fig. 169), so that when the peg is inserted into a switch-hole the two springs $S S'$ are brought into connection with the conductors in the cord. Upon the upper face C of

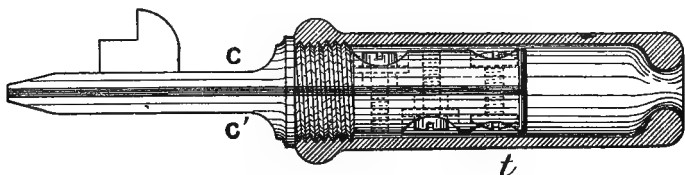

Fig. 169. Full size.

the peg is rivetted a brass projecting piece, which slides into a slot in the upper spring when the peg is inserted in a hole. This projecting piece is so placed that if the peg be inserted between the springs upside down, they will not hold it, but will force it out again, thus effectually securing that it shall be properly inserted. A horn thimble t (shown in section) screws on to the body of the peg, and serves both as a protector for the connection and as a handle.

The line of each subscriber (or *renter*, as they are called by the Post Office) is connected at the exchange to an indicator which, besides acting as a means by which the subscriber can gain attention at the exchange,

serves to show also whether the line is engaged or not. The method employed to effect this forms a special feature of this system. The indicator is shown in front and side elevation by figs. 170 and 171. Upon a disc of brass which forms the base of each indicator is mounted an electro-magnet *M M*, having as an armature a ring of soft-iron *A*, which is so hinged to a small pillar at *a* that it has a tendency to fall away from *M M*, and will do so unless there is a current passing through

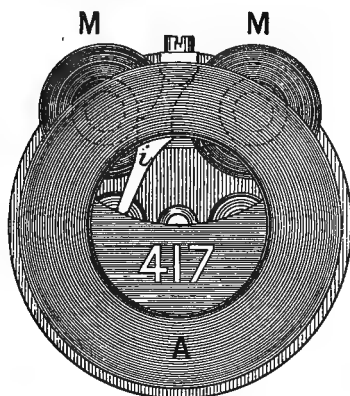

Fig. 170. Full size.

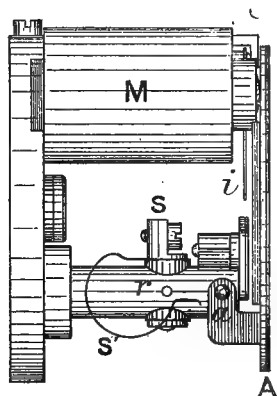

Fig. 171. Full size.

the coils. The ring, which is faced with ebonite, carries a small ebonite plate, which is engraved with the number or name of the subscriber. Pivotted upon a small bridge between the coils, and free to move between the poles, is a small magnetic needle *i*, which deflects to right or left, according to the direction of the current in the coils, or hangs vertical if no current is flowing, and serves as an index to show whether the line is engaged or not. Upon the pillar which carries the shutter is an insulated stud *S*, provided with a light

spring S' , which is brought against the pin r by the action of the hinge when the shutter is not held up by the electro-magnet; if, therefore, a bell and battery be connected in circuit with the stud S and the base of the indicator, the bell will ring so long as the shutter is down, and this method of calling attention can therefore be adopted when desired.

Ordinary Exchange Working.—As already stated at p. 165, the whole of the Post Office system is now worked on the "bridge" principle. The ordinary method of connecting the renters' lines with the exchange is shown in fig. 172.

It will be seen that the lines of each renter are connected one to each spring of the switch-hole and to one end of the indicator coil. In the few cases under the Post Office system in which no "B," or return, wire is used, the lower springs are connected direct to earth.

On referring to the figure, the different conditions of intercommunication will be easily understood. Renter No. 1 is shown as being in communication with the exchange itself. There is no current on the line, as is shown by the fact that the magnetic needle of the indicator is vertical. A peg is inserted between the springs of switch-hole No. 1, the two sides of which are connected (by means of a flexible cord, which is shown in the figure as two parallel lines) to the operator's speaking instrument. The course of the undulatory speaking currents will, therefore, be from No. 1 line "A" to the upper spring of the switch-hole, through the exchange telephone, and back to No. 1 line "B" by way of the lower spring. As a "bridge" on the speaking telephone there will be No. 1 indicator (figs. 170 and 171) wound to 1,000 ω and having a high impedance.

No. 2 renter is shown as disengaged: the switch springs are open, the indicator shutter is up, and the magnetic needle is deflected. The permanent current indicated by the deflected needle will be explained directly.

Again, renters Nos. 3 and 4 are shown as through to each other, the arrangement of the circuit being as shown in fig. 173, where renters No. 1 and No. 201 are shown as communicating. The undulatory speaking currents pass through the switch direct from the line

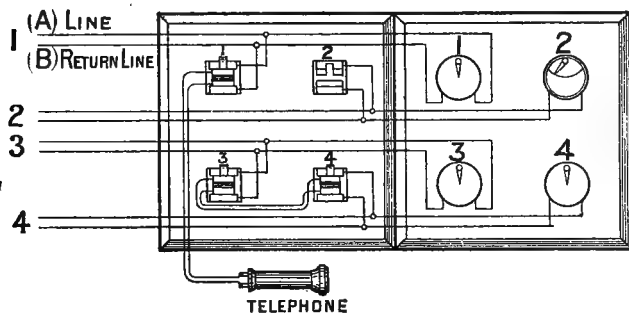

Fig. 172. Exchange Switch, showing "1" speaking to Switch-clerk; "2," Normal; "3" and "4," Through.

without being deformed by the presence of electromagnets. The means by which these different conditions of intercommunication are arranged for will be easily understood.

It will have been noticed in the description of the indicator (p. 215) that the only means of keeping up the shutter is by a current flowing through the coils. As stated there, this forms a characteristic feature of the Post Office system. Each renter in connection with the exchange is provided with a battery, which is so con-

connected with the telephone that, so long as the switch-levers of the telephone are depressed—that is, so long as the tubes or Bell receivers are in their rests—a current from the battery will flow to the exchange lines; this current, passing through the indicator at the exchange,

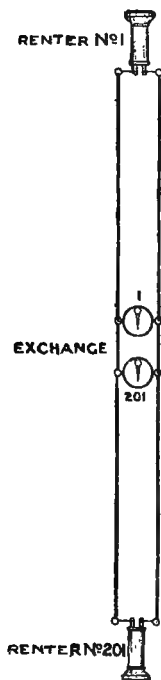

Fig. 173.

enables the electro-magnet to hold the shutter or ring A (fig. 171) in a vertical position, and to deflect the magnetic needle. If, now, the renter desires to communicate with the exchange, he has only to take the tubes from their position of rest. This disconnects the "permanent current" from the line, and the shutter at the exchange drops, thus attracting the attention of the exchange clerk, who thereupon puts a peg attached to one of the exchange telephones into the renter's switch-hole (No. 1, fig. 172), and ascertains what is required. If the renter desires to speak to another renter (say, No. 3 wants No. 4), the exchange clerk calls up the required renter, says, "Through to No. 3," and puts in the through pegs as shown at 3 and 4 in the figure. The calling from the exchange is effected by means of a calling

battery of sufficient electro-motive force to actuate the relay upon the longest line on the exchange system. The "permanent current" passes through the coils of a relay at the renter's office, and this relay, which is for actuating the renter's call-bell, is "biased" against the

permanent current (about 5 milliampères); but when the permanent current is strengthened by the calling current acting in the same direction, the bias of the relay is overcome, and the local circuit of the call-bell is closed.

The permanent currents from all lines flow in the same direction—that is to say, the positive pole of the battery is connected invariably to the "A" line; therefore, as two communicating lines are joined straight through—"A" line to "A" line and "B" line to "B" line—the currents from the two batteries flow in the same direction through the coils of the indicators which are placed in bridge across the lines. Hence, when, at the end of a communication, the two corresponding renters replace their receivers, the currents from both the lines combine, and thus, by deflecting the magnetic needles of the two indicators at the exchange, give notice to the exchange clerk that the conversation is at an end. The pegs are then removed, and the lines left in their normal condition.

Beyond the primary advantages of the permanent current system, such as the automatic indication at the exchange of the conclusion of a conversation between two subscribers, an incidental advantage also arises in the fact that the permanent current acts as a test for the line, and at once indicates when a fault comes on. Further, it shows when a renter omits to replace the tubes in the switch-levers, and so prevents waste of time in calling.

In order to gain the attention of any subscriber who has inadvertently left off the tubes, a "buzzer," or "howler," is provided at the exchange. This is an induction coil, with a make-and-break contact in the primary circuit, by which, when that circuit is closed, rapid intermittent currents may be sent from the

secondary coil to the renter's line; and these, acting upon his telephone receiver, cause a loud buzzing sound and so attract attention.

The arrangement of the different apparatus at an exchange has an important bearing upon the expedition and efficiency of its working—unless the operators are able to see at a glance the condition of every line, and can easily control their several sections, great confusion and much loss of time are sure to arise. The general arrangement of a medium-sized exchange (of from

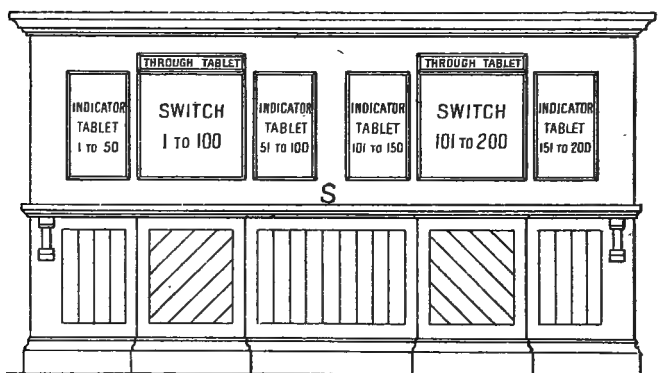

Fig. 174.

100 to 300 renters) under this administration is shown by fig. 174.

Each switchboard of one hundred holes is placed in charge of two clerks, and the corresponding indicators are fixed upon tablets in two groups, one on each side of the switchboard.

Each switch-clerk is provided with a telephone by which to communicate with subscribers, and there are other telephones which are used for sending and receiving telegraphic messages. These telephones are joined

up to a "speaking tablet" fixed beneath each switchboard, with two connection-screws for each instrument. To these two screws a flexible cord is attached which is taken down through the shelf *S* of the switch-frame, round a light pulley, back through the shelf, and then connected to a switch-peg. Each of the speaking telephones can thus be placed in communication with any one of the subscribers on the switchboard, and when not in use the cords of the speaking pegs are drawn beneath the shelf by the pulleys, and so kept clear of the switch in the usual manner.

The form of the switchboard telephone is indicated by fig. 175. The transmitter *T* is of the Moseley type, with a mixture of carbon granules and filaments. The mouthpiece is easily removable, for sanitary reasons. The receiver *R* is constructed with small powerful magnets. The external connections are made by a four-wire flexible cord beneath the cap *C*, and the connections to the receiver and to the press-button *P* in the handle *H* are obtained by means of the rigid brass wires which join the several parts. The press-button provides for short-circuiting the secondary section of the induction coil when hearing becomes difficult. The total weight of the complete instrument is scarcely over 16 oz.

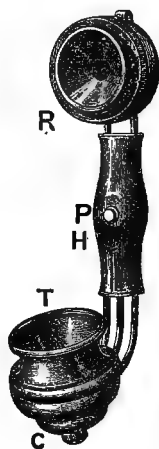

Fig. 175.

Where more than one hundred renters are connected to an exchange, provision is made for the communication of subscribers fixed on different switchboards in the usual way by means of "through tablets"

(fig. 174) fixed above the switchboard. These consist of switch-holes similar to those of an ordinary switchboard.

The principle of "multiple" switches will be fully described in Part IV., where the special features of the multiple switch used by the Post Office will also be explained.

Intermediate Offices.—The special requirements introduced by the existence of an intermediate office upon a circuit have been met by the design of a special intermediate switch for exchange circuits. The principle of its construction is the same as that shown in figs. 123 and 124, and need not therefore be described; its essential difference is that it has only two positions, "DOWN" and "EXCHANGE," of which the latter is the normal position. At the intermediate office, besides the switch and telephone, there are two relays, one of which is polarised and has a magnetic needle similar to that attached to the indicators (*i*, figs. 170 and 171); the other is of the ordinary form (figs. 96 and 97). There is also a trembler bell, which is actuated by either relay.

The connections are shown by fig. 176, from which the local connections of the relays and the microphone circuit of the telephone are omitted for the sake of clearness, and which gives the connections in position "EXCHANGE."

In this, the normal position, the two relays, joined in series, are in "bridge" across the two lines, and a permanent current flows to the exchange from the "down" office. Either office can gain the attention of the exchange by repeated depressions of the press-button on the telephone. In the case of the *down* office, this *disconnects* and restores the permanent current, so that

the magnetic needle of the indicator at the exchange moves repeatedly from left to vertical; but in the case of the *intermediate* office the depression of the button sends a *reverse* current, and its release restores the permanent current; the needle consequently

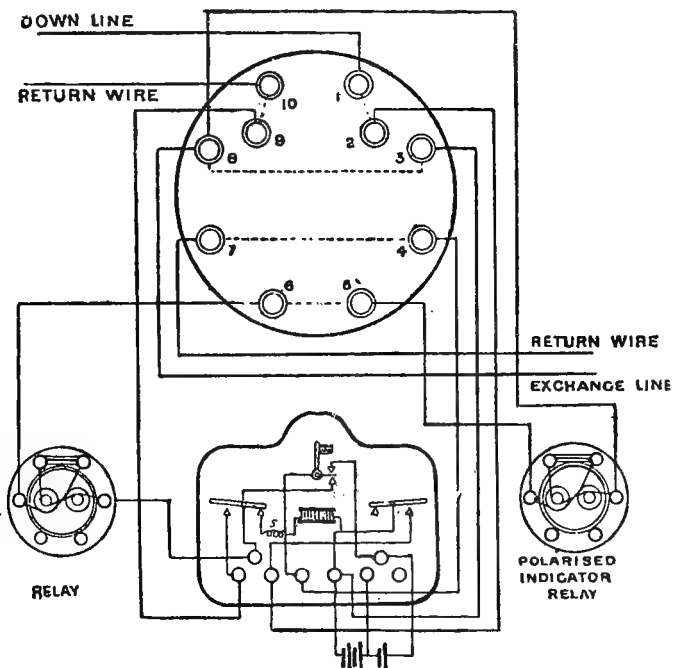

Fig. 176. Exchange Intermediate Switch. Connections for "EXCHANGE" Position.

vibrates from side to side. The exchange clerk therefore easily knows which office is calling. For calling the intermediate, the speaking-telephone peg is inserted reversed (both switch-springs being slotted to admit of this), and one ring is given; while for calling the down office

the peg is inserted in the usual way. The reverse current from the exchange, which is about double the strength of the permanent current, actuates the polarised relay at the intermediate office, which the direct current, of course, cannot do. The exchange current always rings the down-office bell; but two rings constitute the "call" for that office, one ring indicating the intermediate office. The down office is provided with a separate press-button for calling the intermediate, which is arranged to augment without breaking the permanent current, so actuating the polarised relay at the intermediate station without disturbing the exchange. Two rings are

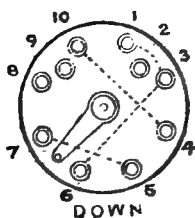

Fig. 177.

given by the down office in calling the intermediate station, while only one is given by the exchange. In order that the intermediate office may be able to call the down office or to answer its call, the switch must first be turned to DOWN, and the button then depressed in the usual way. Turning the switch to DOWN disconnects the permanent current from the exchange, and so drops the indicator shutter; but this does not affect the working, as the indicator needle hangs vertical, and when, at either office or at the exchange, the indicator needle is vertical, it is understood that the line is engaged. In this way all conditions of working on an intermediate circuit are as straightforward and simple as on an ordinary circuit. The internal connections of the switch at position DOWN are shown in fig. 177.

Trunk Wires.—When there are telephone exchanges at neighbouring towns, it is generally very advan-

tageous to connect the exchanges, so as to permit the subscribers of one exchange to communicate with those of the other. This is effected by means of "trunk" wires between the different exchanges. Thus, for instance, the exchanges at Newcastle-on-Tyne, South Shields, Sunderland, the Hartlepoons, Stockton, and Middlesbrough are connected by trunk wires, and the subscribers at any of those towns can therefore communicate with those connected with any of the other exchanges. The number of trunk wires is, of, course, limited, so that it is necessary to limit the time of their use for each communication. Three minutes is the average time occupied, but six are allowed, after which, if other renters are waiting to go through, the wires are disconnected and the renters informed of the fact. If, however, the line is not required, the conversation is not interrupted. Of course proportionate fees must be paid.

There are a few points as regards management which may be mentioned.

The experience of nearly every exchange is that it is more advisable to depend upon numbers than upon names in indicating and calling subscribers. Mistakes in numbers are not so frequently made, and can be provided against, and, when they occur, are more easily rectified; numbers, moreover, are shorter.

Switching is greatly facilitated if subscribers who frequently inter-communicate are placed as near together as possible. The indicators of two or more lines used by the same subscriber should, if possible, be side by side. It is, of course, often difficult to arrange this when the circuits are designated by numbers.

Where telegraphic or other messages are delivered or

received by telephone, the whole message should invariably be repeated back to the sending station.

Numbers and names should be *spelt*, as well as spoken, thus:—"T w e n t y—twenty, f o u r—four : twenty-four."

Even spelling is not always sufficient, difficulty being experienced in the confusion of certain letters—b and p, t and d, m and n, for instance, being mistaken one for the other. This is surmounted by giving words for doubtful letters, thus:—"p for Paris," "t for Thomas," "n for Newcastle," etc.

Ordinarily attendance is given at the telephone exchange so long as the telegraph office to which it is attached is open; but after ordinary business hours the calls are generally so infrequent that the attendants are withdrawn. Provision is therefore made for the renters to gain attention by means of the local circuit of the indicator. This is joined up in circuit with a trembler bell fixed in the instrument-room and a battery; and when the shutter of any indicator falls, the "night-bell" circuit is closed through the insulated contact *S'* (fig. 171), and the bell rings until attention is given. This night-bell circuit is, of course, disconnected so long as the switch-clerks are in attendance.

It is found that the average time occupied by renters for each communication is about three minutes; and it has not been found necessary or desirable to make any restriction as to time, although, if the wires are occupied for a very lengthened period, the exchange clerk is permitted politely to draw attention to the fact.

Regular and prompt attention to every call should be a special feature of every telephone exchange, and under the Post Office system this is strictly insisted upon. No switch-clerk is permitted to have charge of more

than fifty renters, and attention to their inter-communication requirements is the sole duty of such clerk, other special clerks being appointed for the transmitting and receiving of messages. At large exchanges each clerk has to attend to not more than forty renters.

In order to facilitate the accurate taking-off of messages, the message-clerks sit at stalls screened off from each other arranged round a room used only for this purpose.

Every effort is made to prevent the introduction of disturbing noises in the exchange office, which would tend to make communication between the clerks and the renters more difficult and less reliable. To help toward this object ordinary conversation should not be permitted.

The testing of the switch-cords is a matter that must not be overlooked. Each cord should be tested once or twice a day at least. A very effective test used in the Post Office for double wire cords is as follows. A "Wheatstone Bridge" is formed with fixed resistances, of which two of the arms are 1^{ω} and the other two arms $\cdot 5^{\omega}$; a "detector" coil being in bridge. On *opposite* sides of the $\cdot 5^{\omega}$ ratios are two pairs of switch-springs so connected that when a pair of pegs is inserted the cord conductors form part of the two ratios, and, consequently, if there is any defect in either conductor, the balance is upset. A two-cell Leclanché battery is used.

At most telephone exchanges a "silence cabinet" is provided in the public office, which subscribers and the public generally are permitted to use for communication with any subscriber in connection with the exchange. These cabinets are required to be practically sound-proof, and, after a series of experiments, this was secured by the following arrangement:—

The ordinary cabinet is about 3 feet square and 8 feet high, with a pyramidal roof. It is constructed as a frame-work, with as little wood as possible consistent with strength, and provided with a door on one side. The frame thus constructed is filled-in in the following way :—First, every space is filled with 5-lb. laminated lead, fixed about one-third of the thickness of the frame (which is 2 inches) inwards. On the outside of this is placed one layer, and on the inside two layers, of doe-hair felt. The whole is then covered inside and out with Hessian canvas, and, finally, finished with a covering of leather-cloth, the inside lining being white. Within this comparatively light structure even loud external noises are scarcely audible.

It is found convenient to have the telephone fixed on a frame suspended by short leather straps from the top of one side of the cabinet so that it may be as clear as possible of the structure. It is usual to fit these cabinets with an electric lamp. The seat, besides being adjustable for height, like a piano stool, is also lifted in a slide by a strong spiral spring. When a caller sits upon the seat the tension of the spring is overcome, and a flat double spring connects up the lamp-circuit, so that the lamp is alight so long as the cabinet is in use.

The cabinets are also fitted with a writing-desk upon the right-hand side of the telephone ; and upon the left with an adjustable elbow-rest of the form shown in fig. 178. As indicated by dotted lines, the arm can be dropped when not wanted.

Hitherto the telephone has not been very extensively employed for the transmission of public "telegraph" messages by the British Post Office ; although in some

Continental systems it has been largely used. The privacy and comparative silence required for its use render a more or less expensive silence cabinet necessary in small public offices, whereas neither the expense nor the space is needed for the installation of the more generally used A B C instrument, which is worked entirely by magneto currents and requires little more skill on the part of the user than the telephone itself. There

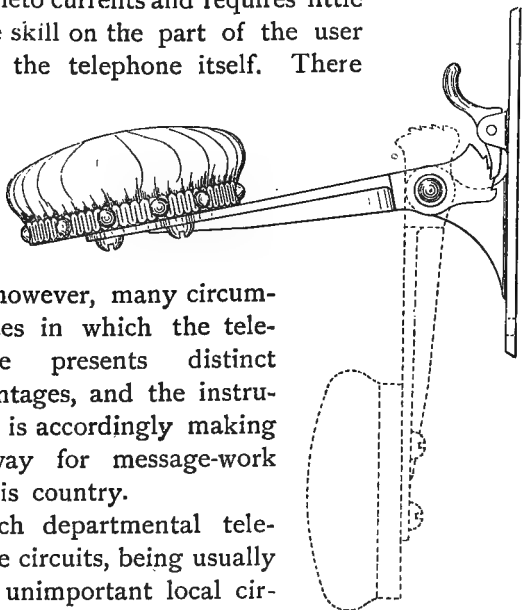

are, however, many circumstances in which the telephone presents distinct advantages, and the instrument is accordingly making its way for message-work in this country.

Such departmental telephone circuits, being usually only unimportant local circuits, are made up of single wires; and it is often convenient to group them into a small exchange. By this means the several stations can either be placed in communication with one another, or speak direct to the exchange. The ordinary form of Post Office exchange switch is used in such cases, and the connections are so arranged that when two circuits are put

Fig. 178. $\frac{1}{4}$ full size.

through the indicator belonging to only one of them is left in "leak" (fig. 179). To effect this, at one end of the flexible cord, the two conductors are attached in the usual way one to each side of the peg, but at the other end *both* conductors are joined to the *upper* side of the peg.

As these departmental exchanges are likely to include circuits of very various resistances, which (from the nature of the circumstances) cannot be compensated for, it is made a general rule that, wherever any circuit on

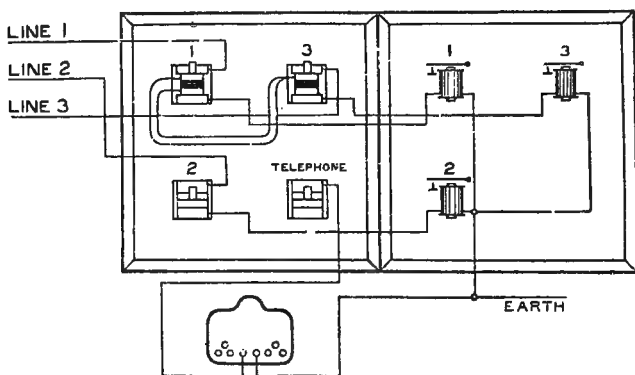

Fig. 179. Connections of Departmental Exchange Switch.

such an exchange embraces two offices, the whole system is to be fitted with 1,000^w relays, and indicators of a corresponding resistance are used at the exchange.

The operators are instructed that if they are able to hear distinctly while they cannot be heard (indicating a fault in the microphone circuit) they should endeavour to speak through one of the receivers.

A recent addition to telephonic apparatus made by the Post Office is a so-called *telephone galvanometer*.

This has been devised to obtain increased security as regards signalling upon coast-guard communication circuits as well as upon circuits used for public messages. It is really an extremely sensitive soft-iron needle pivotted midway between the poles of a 4,000^{ohm}-resistance electro-magnet, whose poles are set at an angle with the vertical, and whose coils are placed in derivation on the line itself. It is thus always in circuit, independently of switch or other contacts, and, if the bell or relay fail to act, there is considerable likelihood of the vibration or deflection of the "galvanometer" needle attracting attention. It has the further advantage of showing the outgoing current; but this is, of course, only a partial security, as the current would pass through the galvanometer coils even if the line were disconnected. For circuits on which 100^{ohm} signalling instruments are fitted, the galvanometer coils are joined in multiple (1,000^{ohm}), and less than 1½ milliampère of current will then give a full deflection of the needle. When the coils are in series (4,000^{ohm}) less than 1 milliampère of current is required to give a full deflection.

The reduction in the total resistance of the ringing circuit at each station by the introduction of this extra derived circuit permits more current to pass to line, so that the "shunt" upon the relay is compensated, and no increase in ringing power is needed. Of course the battery is harder worked. The galvanometers respond excellently with magneto currents.

It may be observed that specifying the resistance is practically only a conventional method of indicating the number of turns of wire. It pre-supposes that the gauge of wire is also defined. With a certain space on a bobbin to be filled with wire, the number of turns would vary as

the square root of the resistance, if no account had to be taken of the silk covering. As the thickness of the covering, however, is about the same for all sizes of wire an irregular factor is introduced, which makes a material difference in the case of bobbins wound with wire of small diameter. In cases such as that just referred to, where the different resistance is obtained merely by varying the connections of the coils, this irregular factor is of course not present, and it is therefore found that the effect varies actually as the square root of the resistance.

CHAPTER XIV.

EXCHANGE "CALL-WIRE" SYSTEMS.

(a.) THE LAW CALL-WIRE PLAN.

THE call-wire system was invented by Mr. Frank Shaw, Engineer of the Law Telegraph Company of New York, and it has been extensively used by that company in New York and Brooklyn.

The characteristic of this system consists in the employment of a special wire, known as the "call-wire" (fig. 180), which passes through a switch in connection with the instruments of a certain number of subscribers, all of which are thus joined

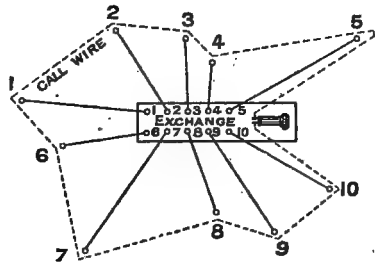

Fig. 180. Principle of Call-wire System.

in circuit on the call-wire, which terminates at the exchange in an instrument at which an operator is constantly listening. The general principle is shown by fig. 180, where the dotted line represents the call-wire passing through each subscriber's station and the firm lines the ordinary subscribers' wires. The call-bell at the subscriber's is on the direct wire circuit. At the exchange the direct lines terminate in pegs at the end of flexible cords.

When a subscriber wishes to call, he introduces his telephone on the call-wire by pressing a switch, and he can then correspond directly with the listening operator at the exchange telephone.

The subscriber on switching in to the call-wire circuit has only to give his number and that of the subscriber with whom he wishes to speak. The operator at once calls the required subscriber by pressing that subscriber's peg against a plate connected with the calling battery or generator.

The two pegs are then inserted into a metallic bar, and the subscribers are in communication.

When the conversation is finished, the subscribers put themselves again on the calling wire, and request the operator to break the connection. It will be seen that in this system there are no indicators whatever. The operator has a head-gear telephone (p. 55), and constantly listens for the directions given on the call-wire. Both hands are free to make switch-connections. In the normal position of the special switch at the subscriber's office the incoming and outgoing ends of the call-wire are connected together, while the subscriber's line is joined to the speaking instrument and the call-bell in the usual way. By pressing the switch the change of connections effected leaves the bell direct upon the subscriber's wire but joins the subscriber's telephone in the circuit of the call-wire. Thus, in either position the exchange operator can call the subscriber, while in the latter the subscriber can communicate with the operator as already explained. After calling, the normal connections are automatically restored by the release of the switch, and the subscriber is ready to communicate with his correspondent.

(b.) THE MANN CALL-WIRE PLAN.

This modification of the ordinary Law system has been successfully worked by the National Telephone Company in the Dundee district since 1882 see (p. 241). It has just been explained how in the Law system each subscriber, in addition to having a direct wire to the exchange, has the power, by pressing a switch, to loop his instrument into a common wire, which, starting from the exchange, goes from station to station and is finally brought back to the exchange after making connection with a group of subscribers' instruments. But this long loop wire into which the subscribers have to switch their instruments is in practice subject to interruption from various causes; and as no other means for corresponding with the exchange is provided, its failure necessitates a suspension of service, which may be of many hours' duration. The breaking of the call-wire, or a disconnection in any one of the numerous instruments through which it passes, will break down the whole of the circuits depending upon that call-wire.

The Mann system is free from these objections, while all the advantages of the Law method are retained. Each subscriber is on the calling wire; and in addition, his direct wire is fitted with an ordinary indicator, which is intended for use only in the event of the operator's wire failing. The calling wire does not make the circuit of all the subscribers' offices, but starts from the exchange in a direction towards the middle of the group of stations which it is intended to serve. The end of this wire is insulated at a convenient point at any distance from the exchange. Into each subscriber's office on either side of this main calling wire is taken a

branch or spur, on which one or more stations are connected by a switch.

The essential difference between the two methods is

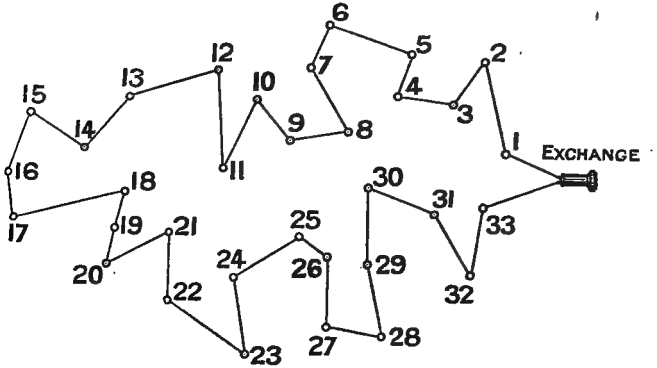

Fig. 181. Principle of Ordinary "Law" Plan.

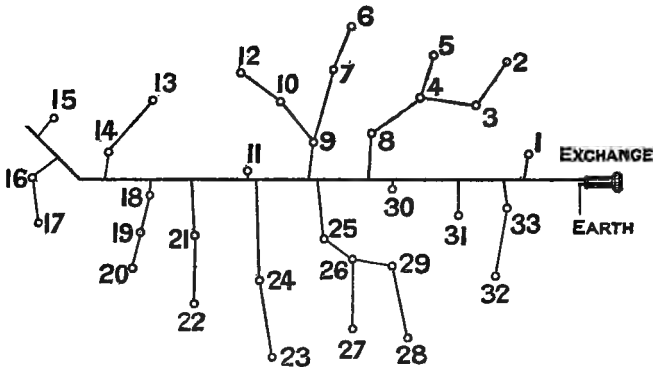

Fig. 182. Principle of "Mann" Plan.

clearly shown by figs. 181 and 182, where a similar group of subscribers is represented connected on the Law and the Mann systems respectively. Only the call-wires are shown. On the two diagrams being com-

pared it will be readily seen that, whereas on the Law system a disconnection at any office, or on the calling wire itself, will break down the whole group, on the Mann system such a fault at one office may break down only that office, or that and a few others; and even a disconnection on the main call-wire may break down only part of the group. The effect of an earth fault depends

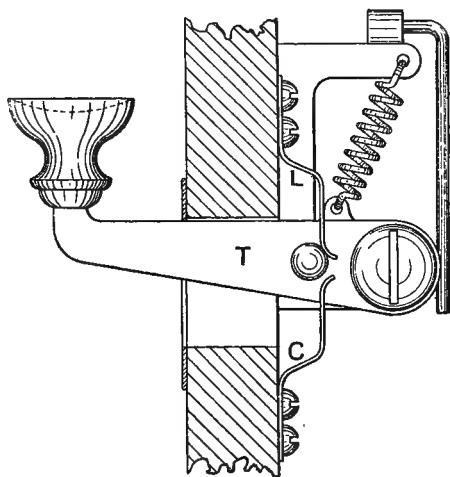

Fig. 183. Full size

upon its position and its resistance. It is desirable to state that the derived circuit plan devised and applied at Dundee in 1882 was described in a pamphlet issued by the Law Company in 1880. In the original device, however, it was not intended that indicators should be used.

The subscriber's key is represented in fig. 183. The lever T is connected permanently to earth through the instrument; and the upper contact L to the subscriber's direct line to the exchange. The lever is kept against

the upper contact by means of a spiral spring, so that the instrument is normally connected to the main exchange wire. The depression of the lever joins the instrument through C to the branch of the call-wire.

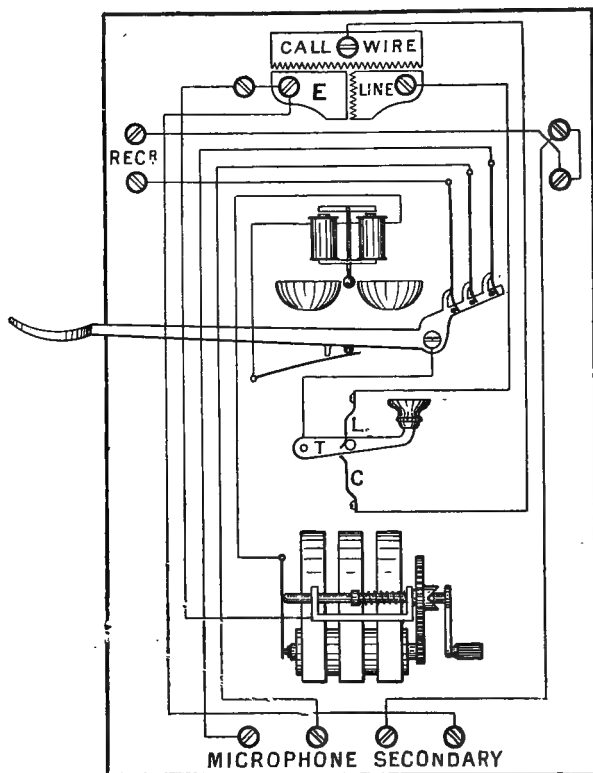

Fig. 184. Subscriber's Instrument fitted with Call-wire Key.

The general connections of the subscriber's instrument are shown by fig. 184.

The ordinary working is as in the Law system. At

the exchange an operator is allotted to each group of from fifty to ninety subscribers, and listens continually at a telephone joined to the calling wire of that group. It follows that the subscriber, on pressing his key, is at once in communication with the operator, and has only, without any preliminary signal or call, to mention his own number and that of the person whom he wants. For instance, No. 25 desiring to speak to No. 50, would press his call-wire key and say: "25 to 50." The operator acknowledges the order by a word, and immediately makes the connection by a flexible cord and pair of pegs. No. 25 then allows his key to rise, turns the crank of his magneto, and rings the bell of No. 50. Supposing that no immediate response is obtained, he can, by again pressing his key, inquire of the operator if the connection has been properly made. At the conclusion of the conversation the two subscribers depress their keys and say to the operator respectively: "Off 25" and "Off 50," or, if No. 25 wants another subscriber, he says: "25 to (say) 42." In the former case, the cord-connection is removed from 25 and 50; in the latter, the 50 end of the cord is transferred to 42. It is frequently the case that two, three, or even more subscribers press their keys simultaneously, but the necessary communication to the operator, consisting, as it generally does, of only two or three words, occupies such a very short space of time that no trouble is experienced, the subscribers having got into the habit of waiting a few seconds if they find, on pressing the key, that someone else is speaking.

If there is a fault on the call-wire, the subscriber discovers the fact immediately, for, on pressing the key, he does not obtain any reply from the exchange. In

such a case, there being an indicator on his own main line at the exchange, he can signal on that by means of his magneto, and the service can be conducted on the ordinary plan until the fault has been removed.

The operators cease to listen continuously after 9.30 p.m., when the calls from the subscribers become less frequent. After that hour, until 8 a.m., a battery and an indicator are switched into each calling line at the

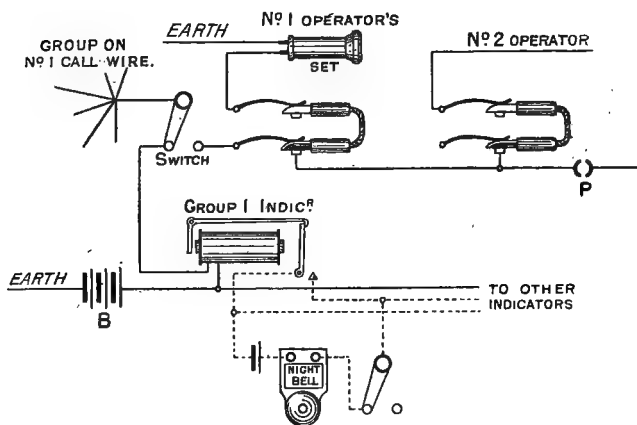

Fig. 185. Call-wire Connections for Group of Subscribers.

exchange, so that the pressing of a subscriber's key completes the circuit of the battery through the indicator upon that call-wire and causes the bell to ring. So long as none of the keys are pressed the call-wire is insulated from earth at every point except at the exchange, so that no current can pass.

The call-wire connections for one group are shown by fig. 185; from which the night-call arrangement will be clear. The battery B consists of about 24 Leclanché

cells, and it is common to all the groups; so also are the bell and bell-switch in the local circuit of the indicators.

During the day the line-switches are turned to the right, and the switch-springs shown are connected by a pair of pegs with short cord, so that the group is in the circuit of the operator's set as described.

A short-circuit piece P is placed between every alternate pair of springs in a wire connecting the lower contacts, and the wire is disconnected at that point during the day. This provides for the working of two groups by one operator at slack times, a change which is effected by the withdrawal of one pair of pegs and the reversal of the other pair in the working operator's switch-springs, so that the "solid" switch-peg connects the lower contact as well as the spring to the speaking instrument through the upper spring. The normal position of the pegs is retained at night, so that to reply to a call the night operator has only to turn the line-switch of the group from which the call has been received, and use the instrument belonging to that group in the usual way.

In some cases the night call is effected by the subscribers' generators, and the battery B is then not required.

(c.) *MILLER'S CALL-WIRE PLAN.*

A modification of Mann's call-wire, due to Mr. J. D. Miller, was introduced at Dundee in 1888, and appears to be an important improvement. It consists in forming the call-wire as a complete loop with branch wires, in a manner indicated by fig. 186, which represents a group similar to that shown in figs. 181 and 182. In the

Mann call-wire a disconnection at any point cuts off all subscribers beyond, while, by Miller's system, the occurrence of a single break in the main call-wire does not affect the service at all, and, even with two breaks, only the subscribers connected between those points are cut off. An earth fault, of course, affects the service according to its position and resistance.

As a consequence of the extra certainty secured by this plan, indicators on the subscribers' lines are entirely dispensed with, as in the original Law system.

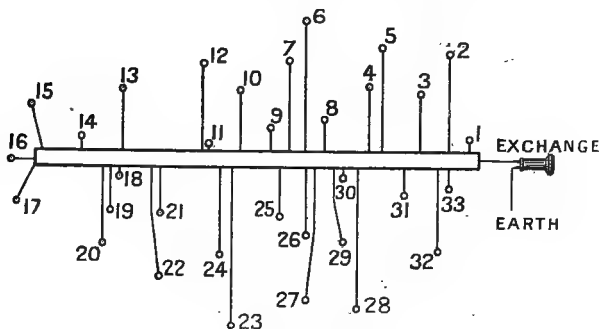

Fig. 186. Principle of Miller's Plan.

There is great difference of opinion among telephone authorities as to the relative advantages of the "indicator" and the "call-wire" systems; but that there is an important future for the call-wire plan in its improved form, or in some further modification of it (see Chap. xviii.), seems to be rightly inferred from the fact that with a subscribers' list of over 600 names the Aberdeen Exchange, worked on the call-wire system, gives such satisfaction that it has been determined to apply Miller's plan to Glasgow also, where there are over 3,000 subscribers to the National Company's Exchange. These

will, of course, be worked by means of a multiple switch. The switch adopted in this case is of the "table" form, in which the tablets lie horizontal and the cords hang from above. This is a form not very much used.

(d.) *BENNETT AND MACLEAN'S CALL-WIRE PLAN.*

This is a modification of the ring-through system described at p. 210, by which the special service wire otherwise required by the Law or Mann systems can be dispensed with. At the subscriber's office the depression of a key puts the telephone between one

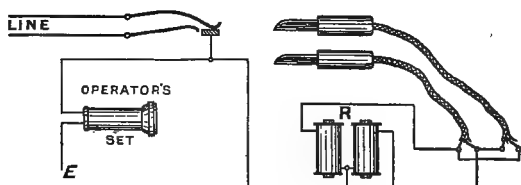

Fig. 187. Connections on Bennett and Maclean's Plan.

wire of the metallic loop and the earth or a return wire. At the exchange there are switch-springs with three contacts (fig. 187), one of which is in connection with one terminal of the operator's telephone, and thence through the telephone to the earth or return wire. The depression of the subscriber's key, therefore, puts him into communication with the operator, as on the ordinary call-circuit system. On the insertion of a peg, the lower contact block is disconnected from the loop, but communication with the operator is re-established by another route—viz., through

a balanced bridge (p.211) across the conductors of the connecting cord, the wire being taken off the middle of the bridge to the same terminal of the operator's telephone that is ordinarily connected direct to line. In this position the subscribers can ring each other, and talk without disturbing the operator or being overheard in the least ; but, as soon as the conversation is finished, the depression of the subscriber's lever re-establishes communication with the operator by way of the earth or the return wire, the balanced bridge in the connecting cord, and the metallic loop, so permitting the termination of the conversation to be notified.

PART IV.
MULTIPLE SWITCHES.

CHAPTER XV.

SINGLE-WIRE MULTIPLE SWITCHBOARD.

THE multiple switchboard, which was first introduced by the Western Electric Company,¹ has been described as the nearest approach to a perfect system that has yet been devised. It is now adopted almost universally for large exchanges.

The connections are made by means of pegs and cords as in the older systems; but, by the method adopted of making every operator practically independent of any other for giving any connection that can be required (and this without the operator having to move from the usual position), the working of a large exchange becomes as simple and as rapid as though it had but 100 subscribers. Indeed, it is difficult to conceive of a telephone exchange of, say, 6,000 subscribers being worked at all upon the ordinary principle, while it is a comparatively simple matter with multiple boards.

Referring to the formula $D = \frac{200N - 100}{N^2}$ which, at p. 209 is shown to give the percentage of direct communications (D) that could be made without assistance where 100-line switchboards are used, it will be seen that 6,000 subscribers, requiring 60 switchboards (N), would involve that nearly 97 per cent. of the connections should be made by the assistance of at least two operators.

¹ British Patent Specifications No. 4,903 (November, 1879), and No. 3,116 (June, 1883).

Fig. 188 represents the principle of a multiple switch. A, B, and C are three sections of a switchboard, which receive the wires of the different subscribers. In the diagram six subscribers are indicated for each section,

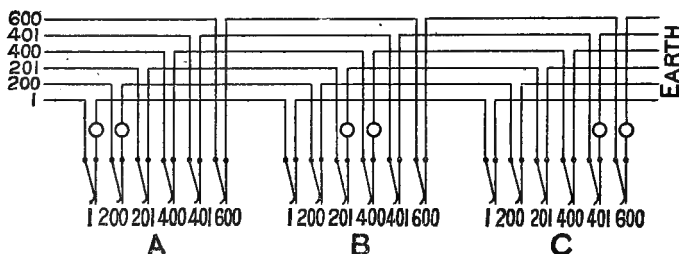

Fig. 188. Principle of "Multiple" Switch.

but in practice a multiple switchboard may accommodate many thousands in each section. It will be seen that the wires of all the subscribers pass to a switch-spring

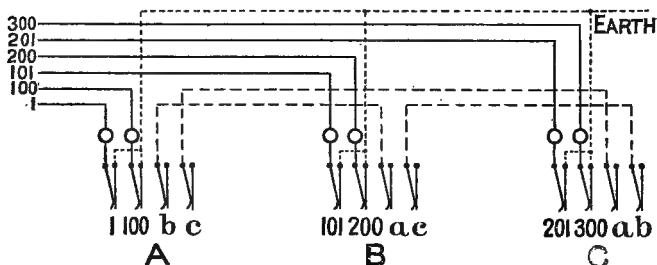

Fig. 189. Principle of Ordinary Switch.

at each of the boards, so that the operator has them all within reach, and can join any subscriber of that section with any wire whatsoever, without the co-operation of a second operator.

Thus, if subscriber No. 200 wishes to speak to

No. 401, the operator at board C, which contains No. 401, need not be informed; but, by placing a peg in the switch-springs so numbered, the operator at A can at once effect the required connection between 200 and 401.

In the same way the operator of switchboard C could make the same connection at that board, if required to do so by subscriber No. 401.

The difference between this system and that hitherto in general use will be easily understood by comparing fig. 188 with fig. 189, which latter represents ordinary switches, with through-connection wires between the boards. To make connection between Nos. 100 and 201, No. 100 switch-hole must be joined by a flexible cord to a special wire *c*, which leads to board C, and connection there made by another cord between *a* and 201. The reverse operation also must be performed for disconnecting the two subscribers at the termination of their conversation.

Fig. 190 represents a section and fig. 191 a half-elevation, of a Western Electric multiple switchboard, from which the general disposition of the apparatus may be understood. The wires of the sub-

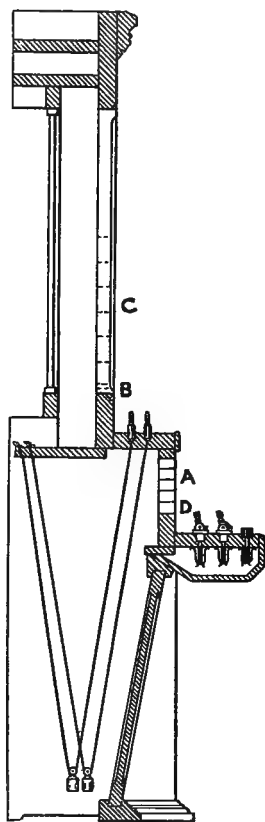

Fig. 190. About $\frac{1}{20}$ real size.

scribers to whom the operators at each section have to attend pass through the indicators at A and the switch-springs at B. These latter are called the "local"

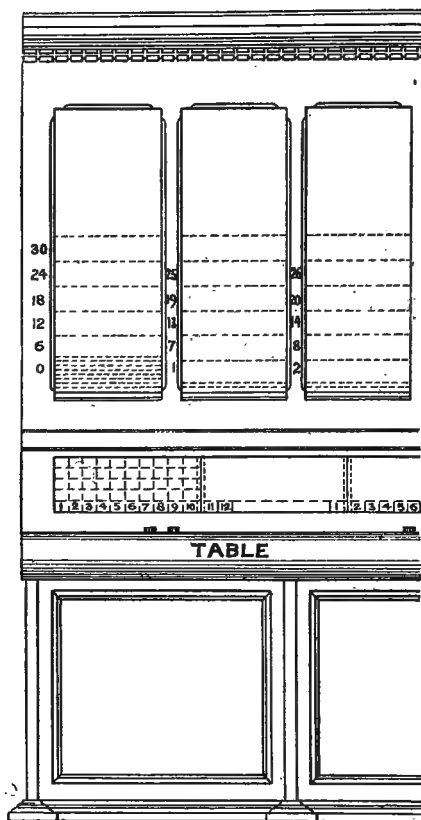

Fig. 191. About $\frac{1}{20}$ real size.

or "individual" switch-springs. All the wires of the entire exchange, including the "local" wires, are brought to the switch-springs at C. Thus the "local"

springs are duplicated in each section of the switch. The springs at C are arranged in hundreds in such order that the operator can easily find the called wire. At D are the ring-off indicators. The pegs for making connection are attached to flexible conductors in the usual way, and always tend to return to their position of rest by means of a pulley and a counterweight. The

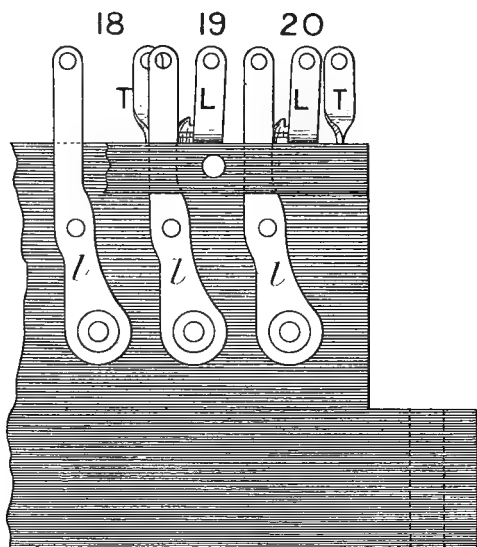

Fig. 192. Full size.

indicators are of the ordinary form, as shown in fig. 144 for the subscribers' call, and as in fig. 149 for ringing-off.

There are six panels in each section, and the strips are placed in groups of one hundred in each—that is to say, in each panel above the two lowest strips (which are the "locals" are five rows, numbered 1—100, and each

successive group of five strips is similarly numbered. The "hundreds" are then indicated on the frame by "0," "1," "2," etc., as shown in fig. 191. It is becoming customary to number the strips 0—99, instead of 1—100, in which case the actual 0 is appropriated to service purposes.

Now when it is considered that every subscriber to a large exchange must be represented by a switch-hole within a space easily accessible to one operator, it will be understood what need there is to make the switch-holes as compact as possible. This necessity was recognised even with the ordinary switches, but the introduction of the multiple principle has so greatly

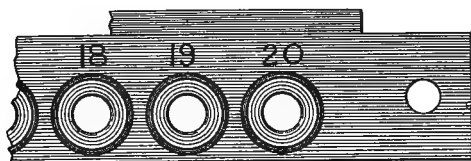

Fig. 193. Full size.

emphasised the need that multiple switch-springs are now spaced at vertical and horizontal distances, centre to centre, of respectively half and five-eighths of an inch.

The construction of the ordinary switch-springs is shown by figs. 192, 193, 194, and 195, which are respectively a plan from above, a front elevation, a plan from beneath, and a transverse section of a switch-spring strip, shown actual size. A complete strip comprises a row of twenty holes, of which three are shown in the three first figures. The strip itself is of ebonite, built up of a thick front block, pierced with twenty holes, and a thinner broad plate with a ridge at the back, upon which the main parts of the switch-springs are planted. The peg

used for a single-wire system has already been shown in fig. 142. The hole in the front strip is bushed with a brass tube, as shown in the section, and also at switch-hole 18 in fig. 194. This tube is fixed by a pin from beneath (shown incorrectly from above in the section). A connection-strip T is soldered to each tube. The stud *l*, upon which the spring L normally rests, is also fitted with

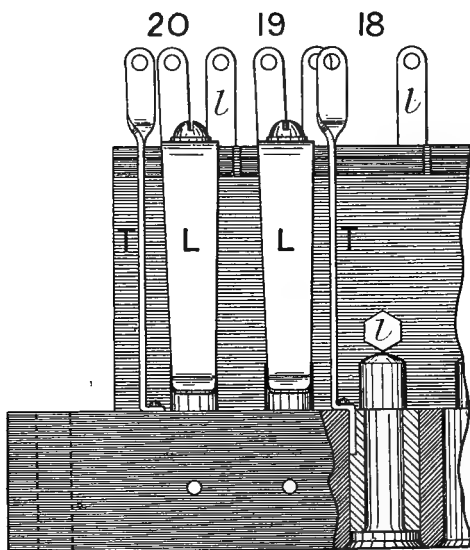

Fig. 194. Full size.

a connection-strip. When a peg is inserted in a switch-hole, its end lifts the spring L from the stud *l* and into contact with itself, and so into connection with both the brass tube and strip T, and with the conductor of the peg-cord. The ends of the front ebonite block project, and so furnish a means of fixing the strips into position. The fixing of the strips in the position shown, rather than

the other way up, is with the idea that they are less liable to accumulate dust at the contacts.

Fig. 196 gives the connections of switch-springs carrying the same number (927), at four distinct sections—D, E, F, G—of the board.

The line coming from a subscriber traverses the test-board, etc., and then passes behind all the sections of the switchboard, through all the switch-springs of the same number, entering by way of L and leaving by *l* without touching the socket T, and finally goes through the electro-magnet of the indicator to earth. But if a peg be introduced into one of the switch-holes (for

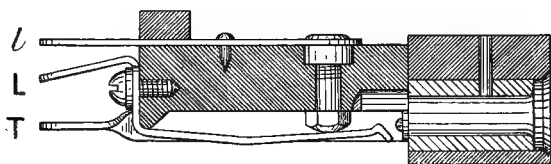

Fig. 195. Full size.

instance, in that of section F, as indicated in the figure); the line passes directly to this peg and its flexible cord, disconnecting all beyond, including the subscriber's indicator.

The figure also shows that all the brass sockets which carry the same number on the different sections are joined together through the strips T by a wire, marked "test-wire." By means of this an operator can ascertain whether the line with which a connection is required is already occupied or not. It will be seen that if no peg be in any hole marked 927, the test-wire of that circuit will be absolutely disconnected; but as soon as a peg is inserted, as shown at F, then the test-

wire is connected to the subscriber's line, and so to earth at the distant end. In the circuit of the operator's telephone is inserted a test-cell, one pole of which is to earth, and consequently if the other end of the telephone set be put to earth, a slight click will be heard in the receiver, owing to the passing of a current. Now if the operator should touch the socket of a disengaged line with the end of a peg in connection with the speaking set, no sound will be heard; but if the required subscriber is already in conversation with another subscriber, the

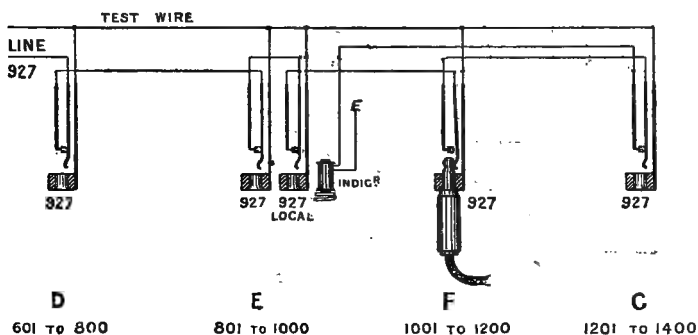

Fig. 196. Connections of a line (927) through four sections of Multiple Switch.

test-wire is placed in connection with the subscribers' earths, and the operator hears a noise which indicates that the line is engaged.

The peg-connections are practically the same as in the case of an ordinary Standard board, except for the insertion of the test-call: they are shown by fig. 197.

Suppose, now, that the switch-springs of, say, No. 1,001, are free, and that the corresponding indicator at section F falls. The operator will at once insert the peg A (fig. 197) into the corresponding "local" switch-

hole, pull over the lever of the table-key, and receive the subscriber's instructions. The insertion of A. has put test-line 1,001 to earth through the subscriber's line, and to any other operator line requiring that number the

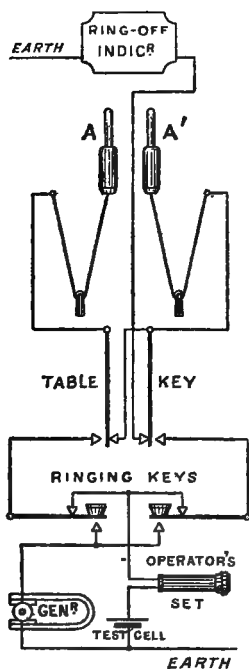

Fig. 197. Peg-connections of Ordinary Single-wire Multiple System.

If, on the other hand, the line required (927) had been engaged, the operator at F would have informed subscriber 1,001 to that effect, and would have tested the line from time to time, so as to inform 1,001 when communication with 927 could be had.

line is now "engaged." Suppose 1,001 requires 927, whose local spring is on section E. The operator at F, still listening on the telephone, touches the socket of multiple-hole 927 on section F with the end of peg A', and if no click is heard the peg is thrust home, and the right-hand ringing key is depressed, thus calling the subscriber (fig. 197). As soon as the ringing key is released the two subscribers are through, and the operator then restores the table-key, leaving the ring-off indicator in leak upon the lines and the engaged connection applied to each.

When the conversation is finished, the subscribers give one or two turns of the handle of their magnetos, the disc of the ring-off indicator drops, and the operator removes the pegs.

Even a line which is brought to the same "local" group must, of course, be tested before connection is made with it. If the test is not properly applied it may happen that three subscribers are placed in communication with each other, leading to much irritation and confusion.

The working of a multiple switch of any number of subscribers thus becomes almost as simple and as expeditious as the operation of an ordinary 100-line board. In fact, the only additional work involved is the engaged test, which can scarcely be considered a separate operation, inasmuch as when the line is disengaged the "test" merely involves a very slight pause during the insertion of the second peg.

The simplicity of working enables the operators to attend to subscribers' calls much more promptly than by any other system when more than 100 are on the exchange, and, as the extension of an exchange naturally involves a larger average of calls from each subscriber, the adoption of multiple switches prevents an increase in the proportion of operating expenses by enabling an operator to attend to the increased requirements of the same number of subscribers.

Reference to some points of administration in connection with the number of local springs to be allotted to each section may be conveniently made at this point.

It has been already stated that each multiple spring-strip contains twenty switch-holes, so that *five* strips provide for a hundred subscribers. It is now usual to fit each section of the multiple board with six panels, each being the right width for fitting the strips. This, with the latest arrangement of iron frame, makes the total length of a complete section 5 feet 7 inches. The

height then regulates the ultimate capacity of the board. The strips are fitted in the spaces beginning with the "local" springs, which make up (say) two rows the whole length of the section. The "multiple" strips are placed in regular order, the five lowest in the left-hand panel being marked "0," and comprising numbers 1—100, the corresponding five in the next panel, which comprise numbers 101—200, are marked "1," and so on; thus the second set of five in the left-hand panel includes numbers 600—700, and is marked "6." This means that for every $2\frac{1}{2}$ inches of height in the "multiple" panels the capacity of the board is increased by 600 subscribers.

The determination of the number of "local" springs to be apportioned to each section must depend upon various considerations. For instance, assuming a certain number of "locals" to each section, the higher the "ultimate capacity" of the exchange the greater will be the number of sections required, and, if there is good reason for fixing this ultimate capacity, it may be clear that the possible accommodation will not suffice for such a number. An increase in the number of "locals" apportioned to each section, however, will correspondingly reduce the number of sections and the space required. Thus, with an exchange for which an ultimate capacity of 6,000 has been fixed, if 200 "locals" to each section be adopted, 30 sections will be required, whereas, on the basis of 300 locals to each, only 20 sections will be needed. Allowing in each case for two extra half-sections at the ends, the lengths of the whole switchboard would be respectively about 178 feet and 120 feet.

This consideration will at once make it clear that for many reasons it is desirable to make the number of

“locals” on each section as high as possible. Not only will the space required be proportionately reduced, but the first cost will be less, there will be a reduction in the length of cabling behind the switchboard, and the number of points of possible failure owing to bad contact will also be diminished.

Here, however, another requirement must be allowed to have very considerable weight. The whole object of the multiple switch is to secure increased efficiency by rendering every operator as far as possible independent of any other, and to allot to each only such a number of subscribers as can be properly managed. Nothing then must be done that will in the least interfere with this efficiency, and it must be constantly borne in mind that the greater the actual number of subscribers on a switch the fewer can each operator attend to. Then arises the question, Cannot more than two operators be placed at each section? and it is in this direction that one possibility of reducing the number of sections seems to lie.

Assuming that the whole multiple switch is in one continuous line, the same plan of working may be adopted as has already been explained in connection with the ordinary switchboards (p. 206). That is to say, the operator, for instance, in charge of the left-hand portion of section B can utilise indifferently the right-hand portion of that section or that of section A, and so with the others. Now the length of the sections is quite sufficient for a third operator to be placed in the centre of each, so that each section may be in charge of three operators. Where space is very limited, it is even possible to put four operators at one section. This, however, means overcrowding and reduced efficiency,

because each then needs some assistance from the others, besides which there remains no scope for supplementary assistance in conditions of extra pressure. It may then be assumed that three operators at each section is the most that should be ordinarily contemplated. Now on the earlier multiple boards it was assumed that the operations would be so greatly facilitated that each operator would be easily able to attend to 100 subscribers in ordinary circumstances, and this may be so in some cases ; but the more usual experience is that 300 subscribers allotted to each section of an ordinary multiple board is excessive and beyond the limit at which efficient manipulation can be secured. This has led to the adoption of the plan of fitting 240 subscribers for each section, thus giving each operator 80 as the limit. It may here be observed that the operators should, and that in practice they do, assist each other without inconvenience to themselves : for example, by the insertion or removal of a peg in a position that is out of reach of a colleague.

The next point to which reference may be made is the number of pairs of pegs with ring-off indicators and table-keys that should be apportioned to each section. In France, where 300 "locals" are brought to each section, 50 pairs of cords are fitted—thus providing for the simultaneous connection of 100 subscribers, or 33 per cent. On the Manchester boards—one of the earliest and most complete of the multiple boards as yet fitted in this country—45 pairs of cords are provided for the 200 subscribers brought to each section, or provision for simultaneous connection of 45 per cent. of the subscribers. As 50 ring-off indicators can be conveniently placed in one row upon a section of board, that presents itself as

a suitable number to use, and, assuming the adoption of this with sections providing for 240 subscribers, it will be seen that over 40 per cent. of the subscribers can then be simultaneously connected. This is unquestionably ample provision; Mons. de la Touanne² even suggests that 25 per cent. is sufficient, very reasonably pointing out that a superabundance of means of connection may encourage carelessness in attending to the ring-off signals at busy times.

As regards the allotment of subscribers to certain sections, even in a multiple board, there is some scope for care in this matter. Very busy subscribers, or a large number whose busy time coincides, should not generally be placed in the same group of "locals." Further, subscribers who are in frequent demand may with advantage be placed as far as possible in the lower numbers, so that their switch-holes are more easily accessible in the multiple panels, thus facilitating the operators' work.

Spare switch-holes may conveniently be closed with small plugs of wood, which give a permanent indication to the operators as to which holes are not connected, if such numbers are asked for by subscribers.

The question as to the highest "ultimate capacity" that can be properly fixed for the efficient working of a multiple switch depends for its decision upon the limit beyond which the operators at any section cannot properly manipulate the section without seriously interfering with each other. At present no practical experience of this limit is forthcoming, inasmuch as the largest existing exchanges do not exceed 6,000 subscribers. Experienced authorities, however, agree that it is not likely that 15,000 can be exceeded, and it

² "Matériel pour Bureaux Téléphoniques," p. 73

seems safer to put the number much lower (say 10,000) with the present facilities.

Incidental reference was made at p. 258 to additional half-sections of switchboard at each end of a range of multiple switch. This is usual and necessary, in order to give the operators at the end sections the same facilities for multiple switching as those at other sections. These half-sections, of course, require that only the multiple panels shall be fitted. Every separate range of board requires these terminal half-sections.

SINGLE-CORD MULTIPLE SWITCHBOARD.

Amongst the various devices in multiple switches which have been put to a practical and extended test Scribner's single-cord board is decidedly noteworthy. The simplification in working secured by the single-cord standard switchboard (p. 200) led naturally to an attempt to secure a similar advantage in connection with the multiple system. The general disposition and form of the apparatus for a single-wire system is shown diagrammatically by fig. 198.

The *key* A and the *earth-switch* B take the place of the usual table and ringing keys, one of each, together with an indicator and a peg, C, being allotted to each line.

It may be explained that the normal connections of key A are as shown, that is, *a* is connected to *b*, and *c* is connected to *d*; but, by depressing the button P, *c* may be connected to *e* instead of to *d*; and by pushing P forward the ebonite block may be made to slide under *a*, so disconnecting it from *b*.

As regards the earth-switch B, when the peg C is at rest its metallic shank (which is in connection with the

d through spring *f* and the shank of *C*. Further, when *C* is at rest spring *f* is pressed forward, so that its point clears the end of spring *h*, which, by its own elasticity, is kept free of spring *g*. When, however, *C* is lifted from its normal position, *f* at once springs back, and its end comes into contact with the end of *h*, forcing that into contact also with *g*.

The system of working will now be easily followed. It will be observed that the incoming currents, after passing through the switch-springs and the indicator coils, go through spring *f* to earth. On the fall of an indicator shutter, the operator has only to raise the corresponding peg to be at once connected (through springs *a*, *b*, *g*, *f*) to the calling subscriber's line. On instructions being received, the required subscriber's line is tested with the tip of the calling subscriber's peg, and if the line is disengaged (so that there is no sound) the peg is inserted and the subscriber called by the depression of the button *P*. When the subscriber replies, the operator's instrument is cut out of circuit by pressing forward *P*, so as to separate *a* and *b*.

The calling subscriber's indicator remains in circuit and serves for the "ring-off" signal. As it is in direct circuit, it must necessarily be of the small pattern (fig. 144) wound to a low resistance.

In order to provide against possible faults in the earth-switch or key, it is usual to fit a number of table keys and pairs of pegs, so that double-cord working can be resorted to if necessary.

The single-cord principle no doubt tends to increase the working speed to some extent, but not so much probably as might be expected, while the increased complication of parts, the difficulties in maintenance,

and other drawbacks have prevented its extended use. Some large exchanges, however—notably in Germany—have been fitted on this system, and give great satisfaction. One hundred subscribers can be allotted to each operator.

OESTERREICH'S MULTIPLE SWITCH.³

Although this switchboard, devised by an official of the German Post Office, has, we believe, not come into practical use, it is yet sufficiently distinctive in principle to merit description.

The general construction of the switch-strip is indicated by fig. 199, from which it will be seen that each switch-

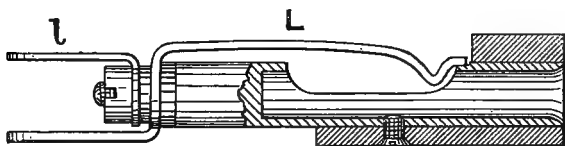

Fig. 199. Full size.

block consists merely of a spring and a contact-strip in connection with the engaged-test ring. The local and multiple switch springs of each circuit are then connected as shown by fig. 200, which shows that there is a permanent current flowing to each line from the exchange. A battery, B, with one pole connected direct to earth, is common to a large number of lines, and in the indicator circuit of each line is inserted a resistance coil R, to reduce the current to a very small value. The "line" at each hole is connected to the front socket, and the spring is on the battery circuit. The peg-circuit is on

³ British Patent Specification No. 15,873 (Oct., 1890).

much the same principle as some already described, except that only a single ringing key is used for each pair of pegs, and that the peg in connection with which this is placed is a double one. The single peg must always be inserted in the calling subscriber's switch-hole, and the double peg in that of the required subscriber. The two kinds of peg are quite separate, the row of single pegs being below the "local" switch-holes in which they are invariably used, while the double pegs are arranged below the "multiple" holes. Further, there is a "galvanoscope" in circuit across the double peg when the table-switch is turned

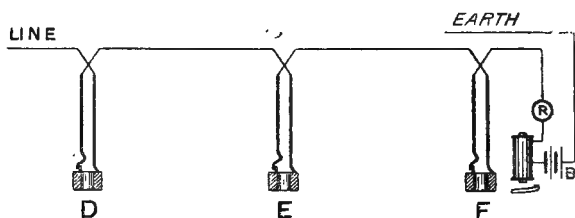

Fig. 200. Line Connections of Oesterreich's Switch.

to the speaking position. Now, the tip of the double peg is of such length that when the peg is partly inserted the tip lifts the spring while the outer part is in contact with the line-socket: thus the galvanoscope is placed in circuit across the spring and the socket. If, therefore, a current be passing—that is, if the line be disengaged, the fact will be indicated on the galvanoscope, and the peg will at once be pushed home. In this position the spring rests on an insulating segment, and the tip is disconnected. The insertion of the single peg in the same manner disconnects the corresponding

spring. It will be observed that it is this disconnection of the battery-circuit spring, which, by cutting off the permanent current, gives the engaged signal.

One ringing key and one galvanoscope are required for each operator.

Another departure from the general practice is in the arrangement of the switch-spring strips. These are so disposed that, while the lowest holes are horizontal from front to back, the highest are inclined at an angle of about 30° , the intermediate strips varying gradually between the two positions. The claim is that the manipulation of the higher rows becomes by this means almost as little fatiguing as that of the lower.

CHAPTER XVI.

MULTIPLE SWITCHES FOR METALLIC CIRCUITS.

(a.) System with Single-spring Switch-holes.

UPON the ordinary plan of working multiple switches with metallic circuits the switch-springs are of precisely the same pattern as those already described for single-wire circuits (figs. 192 to 195). Indeed, it is now

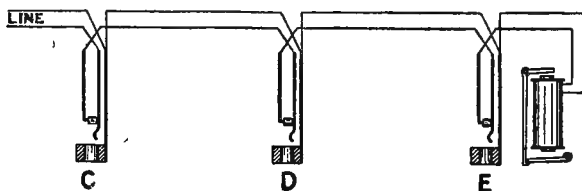

Fig. 201. Connections of Metallic Circuit with Single-spring Switch-holes.

very usual to wire boards for metallic circuits throughout, even when the system is a single-wire one, thus providing for transition to double wires without the necessity of disturbing the switch. The connections also remain the same, except that the "test wire" becomes also the return line of the circuit, to which one end of the indicator-coil is connected. This is shown by fig. 201.

The alteration of the peg-circuit is, however, rather considerable. The pegs themselves are, of course, double, the same as that shown in fig. 163, except that

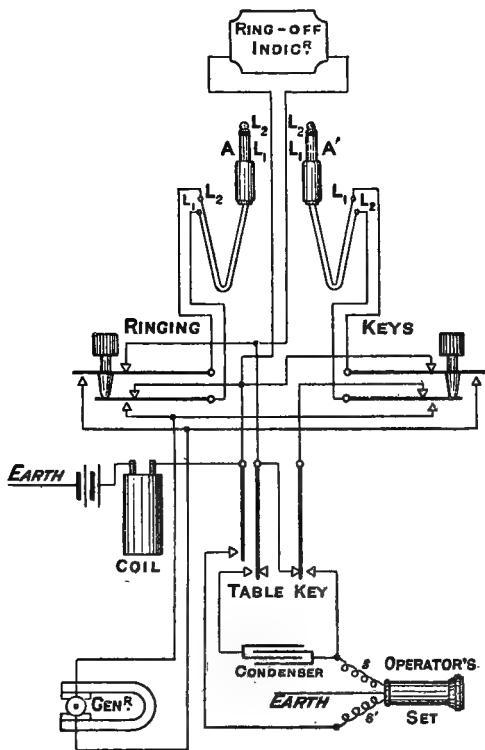

Fig. 202. Peg-circuit Connections for Metallic-circuit Multiple Switch with Single-spring Switch-holes.

they are of the smallest size (similar to figs. 142 and 143).

The diagram of connections for a pair of pegs A and A' is shown in fig. 202, from which it will be seen

that, besides the use of rather more complex ringing and table keys, there are introduced a special coil in circuit with the test battery, and a small condenser in connection with the operator's speaking instrument. It will also be observed that the receiver coils and the secondary coil s, s' are wound in two separate sections.

Now, when a call is received the operator replies by inserting peg A into the corresponding switch-hole and turning the table-key. This places the operator's

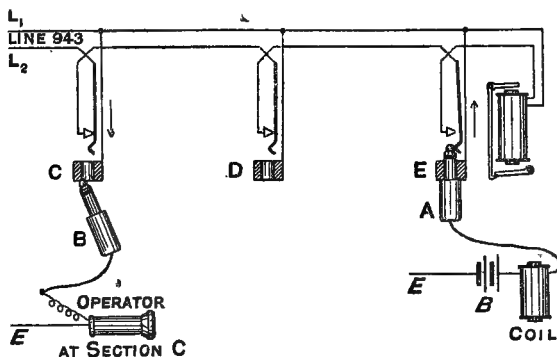

Fig. 203. Showing "Engaged Test" for Ordinary Single-spring Multiple Switch.

instrument in speaking connection through the condenser; it also brings the ring-off indicator into bridged circuit across the lines and connects the test-battery to line L_1 and (which is the object of the connection) to the test-sockets of that number at each section. When the instruction as to the connection is known, the operator applies the engaged test to the required line, and if *no* sound is heard the through connection is made by means of peg A'; the operator calling the subscriber by means of the right-hand ringing key in

the usual way. If, however, a click is heard on the test being applied, the calling subscriber is informed that the required line is engaged.

Fig. 203 shows in simple form how the engaged click is obtained, assuming that a subscriber at section C has asked to be put through to No. 943, a line which is already engaged at section E. The A peg of a pair having been inserted at E, the impedance coil and battery *B* are thereby connected with the test-sockets of switch-holes 943, and, consequently, when the tip of the peg B is brought to the socket at section C, a current passes from *B*, through one section of the operator's speaking instrument, and so to earth, thus causing a distinct sound in the telephone. In the normal position, with no battery and no earth-connection on the line, the consequent absence of sound shows the line to be disengaged. The coil in the test-circuit is, of course, of high resistance, and is formed as a closed electro-magnet, so as to present considerable impedance.

(b.) Switch with Distinct "Engaged Signal" Circuit.

There can be no doubt that the connection of an earth-shunt upon one of the wires of a metallic circuit as above described for "engaged-test" purposes is distinctly inadvisable; in the majority of cases it leads to slight, and in some cases to considerable, disturbance. With this in mind the London engineering officers of the National Telephone Company devised a very simple and ingenious modification of the original system by altering the switch-strip construction. Figs: 204 and 205 show respectively a

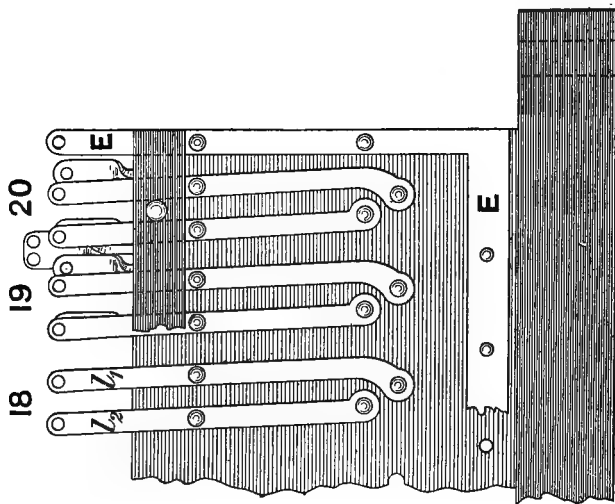

Fig. 205. Full size.

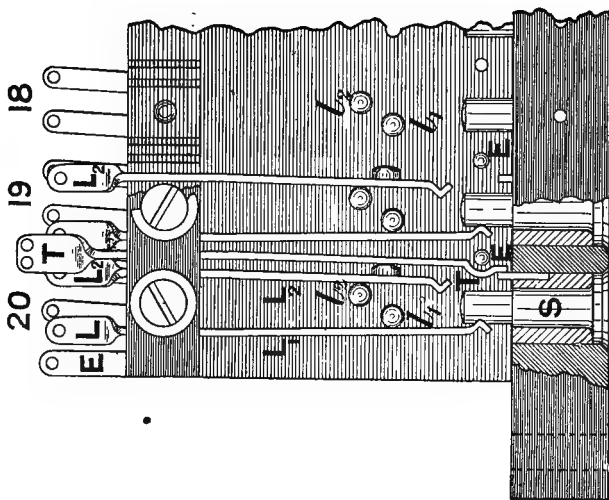

Fig. 204. Full size.

plan from beneath and one from above of part of a strip of this form. The springs are arranged on edge upon the strip, fitted in slots in the back-edge and clamped by a narrow strip of ebonite, which runs the whole length of the switch-strip and is fixed by screws opposite each switch-hole. The two springs L_1 and L_2 make connection normally with studs l_1 and l_2 ; but when a peg is inserted these connections are broken, and L_1 and L_2 are connected respectively to the sleeve and the tip

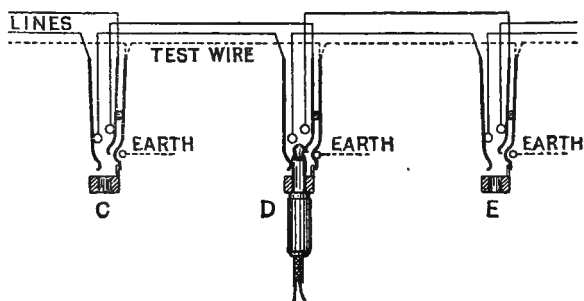

Fig. 206. Line-connections showing distinct Earth-connection (at D) for "Engaged Test" Signal.

of the peg. In the normal position spring T rests upon a small projection on the socket S of the switch-hole, but the insertion of a peg serves, by the intermediary of a small ebonite piece fixed upon L_2 , to break this connection and press T into contact with the pin E.

The application of this device will be easily understood by reference to fig. 206. It will be seen at once that in the normal position the lines pass through the springs L_1 and contact-studs l_1 , and the springs L_2 and studs l_2 to the indicator; and that the test-wire springs T,

resting against the projection upon the sockets, are altogether disconnected. When, however, a peg is inserted, as at D, the two sides of the peg are connected

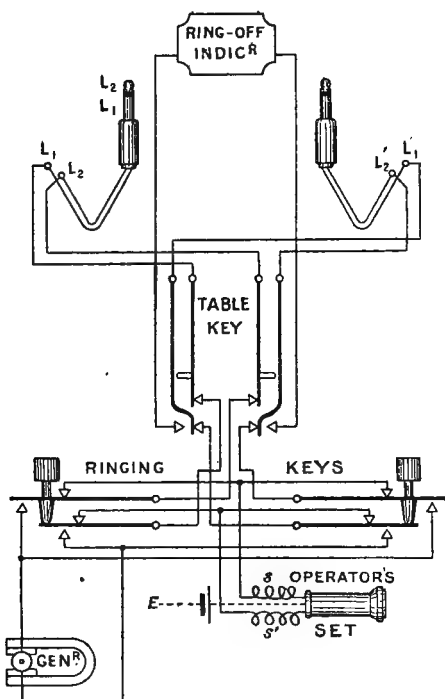

Fig. 207. Peg-circuit Connections, with distinct "Engaged Test" System.

to the lines, the circuit beyond is disconnected, and the test-spring T is connected through the pin and the strip E (fig. 205) direct to earth. The earth-connection of the test-wire is thus effected without in any way

interfering with the line itself, which is kept quite clear and separate. Thus also the engaged signal is applied in its most favourable way—by a direct earth-connection at the exchange itself.

The peg-circuit connections are of a slightly more simple character, as shown by fig. 207. The receiver and secondary coil are double wound, the centre of the receiver being connected through the test-cell to earth. It will be seen that in the "through" position both the outer and inner springs of the table-key are connected to the outer contacts, so that the lines are straight



Fig. 208. Operator's Speaking Circuit on distinct "Engaged Test" System.

through, with the ring-off indicator in bridge. In speaking to a subscriber the operator's instrument is in circuit, with an earth-connection in the centre through the test-cell, as shown in fig. 208.

(c.) *Western Electric "Branching" System.*¹

This system, which is adapted for metallic circuits, adopts the principle of connecting the indicators in bridge and having the line-contacts at each section of the switch as permanent branches instead of having a break in the line-circuit. The test system also is entirely distinct from the lines, and, in addition to furnishing the "engaged" signal, it is also utilised to automatically restore the indicator. These special features in this, the latest development of multiple-

¹ British Patent Specification No. 4,428 (March 5, 1892).

switch practice, appear to possess some distinct practical advantages.

The absence of any spring-contact in the line-circuit at the switch-springs eliminates the danger of interrupted or high-resistance lines due to dust or other foreign substances getting between the contacts ; and the automatic restoration of the indicator not only saves the work of the operator, but permits of the indicators being placed out of reach, and the space hitherto occupied by them to be used for switch-springs, thus materially increasing the capacity of a switchboard in the same space. There is also the very important recommendation that the reduction in the operators' work enables them to attend to a larger number of subscribers than on other systems, thus leading to economy in working expenses. The unit of sections in these boards, so far as at

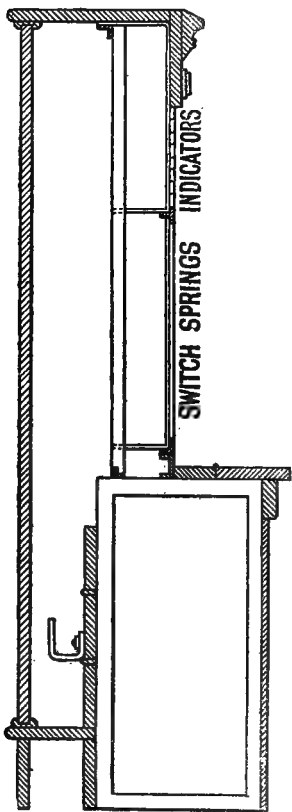

Fig. 209. About $\frac{1}{20}$ real size.

present made, is 300 subscribers, as against 240, which is the highest number per section that three operators can properly manage on the older system.

Fig. 209 shows in section the general arrangement of the switch, and fig. 210 shows the keyboard. Iron switch-frames are employed to economise space, and the plan of hinging the keyboard gives facility for attending to faults in the peg-circuits. It will be seen from fig. 210 (which represents one-third of a section) that each section has 45 pairs of pegs.

Several modifications of this general system have been devised, but the following description of the first plan put into practical operation for exchange work will sufficiently indicate the general principles.

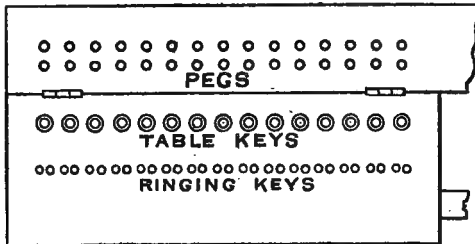

Fig. 210. About $\frac{1}{10}$ real size.

Fig. 211 is a plan view and fig. 212 a cross-section of the switch-spring, in which the brass socket L_1 is one line-contact, the short spring L_2 the second line-contact, springs T and t test-circuit contacts, and T_1 a test-ring lining the front of the switch-hole as usual. In this case, however, the test-ring is somewhat larger in diameter than the peg, so that contact may not take place between them. The test-ring T_1 is permanently connected with the spring T .

The peg used has, in addition to the usual two cord-connections, a third short-circuiting device, and presents an improvement upon previous three contact-

pegs. This peg is shown in fig. 213, in which L'' is the tip making contact with line-spring L_2 ; L' the sleeve making contact with line-socket L_1 ; and T a narrow ring slipped over the insulation between the tip and the sleeve of the plug, which ring serves to connect together

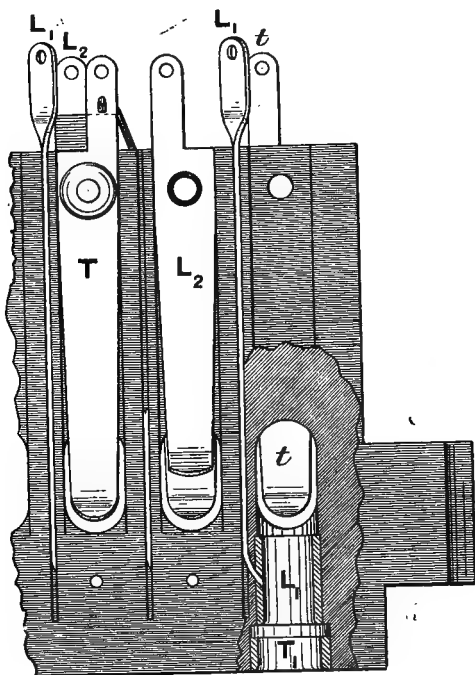

Fig. 211. Full size.

the test-circuit springs T, t , so completing the local or test circuit.

The indicator consists essentially of two coils mounted on opposite sides of a supporting plate. The coils are described respectively as operating coils and restoring

coils. The "self-restoring" indicator is shown in side elevation by fig. 214. The back armature A, pivotted at C, is fitted with an arm D, which terminates in a catch. This armature is actuated by line-currents passing through the back section O of the sheathed electromagnet. This is so far the usual arrangement (see fig. 149). The catch at the end of D holds up a soft-iron recessed armature A', into the centre of which

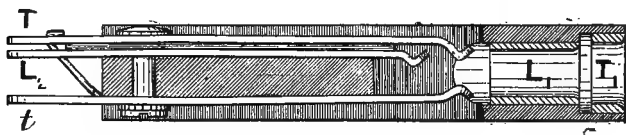

Fig. 212. Full size.

the front end of the core of R protrudes. This front armature is pivotted at its lower edge, and in front of it is a light aluminium shutter P, which, being pivotted above, has a tendency to hang vertical. When A' is detained by the catch on D, P is free so to hang, but if A' be released it will tend to fall, and will then

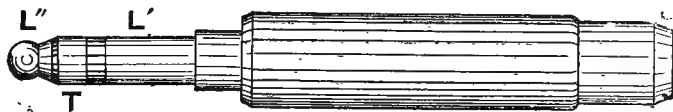

Fig. 213. Full size.

thrust P forward as shown in fig. 215. If now a current pass in the restoring coil R, the shutter-armature A' will be attracted and brought again behind the catch, and the shutter P will be automatically restored. So long as the current remains on, however, the position of A', and consequently of P, is independent of the catch.

The operating coil is bridged permanently across the lines, as shown at O in fig. 216; one end of the restoring coil R is connected to the springs T of its series, and its other end through a battery to earth. When a call comes from line the operating coil is affected, and causes the catch on D (fig. 214) to release the shutter-armature A', which presses out the indicator P. The insertion of a peg

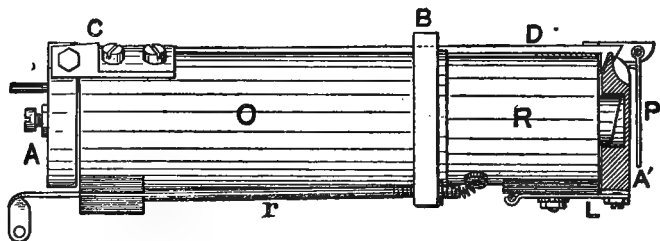

Fig. 214. $\frac{3}{8}$ full size.

into the switch-spring completes the circuit of battery B through the restoring coil by way of the test-springs T and t, which are joined across by the ring T on the

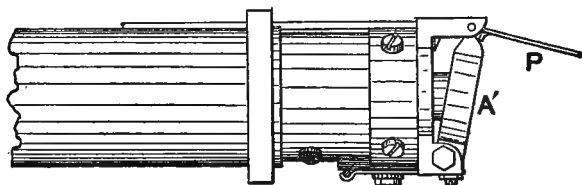

Fig. 215. $\frac{3}{8}$ full size.

peg. By this means the shutter-armature is attracted and again brought beneath the catch, and the indicator P therefore automatically falls to its normal position; further, it cannot be again actuated until the peg is removed, because the shutter-armature is fully attracted so long as the circuit of the restoring coil is complete, and in this position it locks the catch, so that

the armature *A* cannot be actuated by any signal-currents sent from the line. Bridged across the circuit of each pair of cords by which connections are made is a similar ring-off indicator, and in the speaking or table key are contacts by which a local circuit is completed, which serves to restore the ring-off indicator in a similar manner.

As the indicators are permanently bridged across the lines, they are arranged to give considerable impedance by being wound to a high resistance and being constructed with a soft-iron sheath (p. 192).

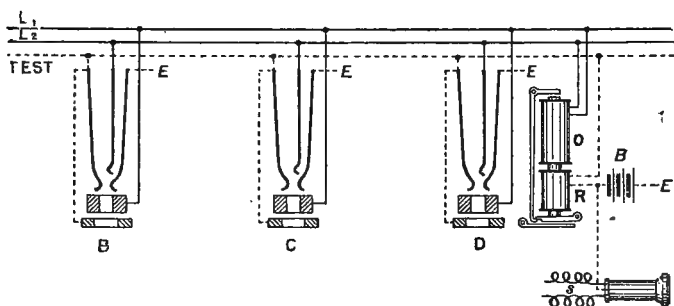

Fig. 216. Line-circuit Connections on "Branching" System.

The peg-circuit connections are shown in fig. 217. The receiver and the secondary coil *s s'* of the operator's telephone are double-wound, and the centre of the receiver is connected to one pole of an earthed battery, as shown. The restoring-coil circuit of the ring-off indicator is completed through battery *B'* and one spring of the table-key when the lever is turned to the speaking position. If now peg *A* be inserted in the local switch-hole of a calling subscriber—say, at section *C*—and the

speaking key be turned, the ring-off indicator will be automatically restored ; and the subscriber's instructions received on the operator's instrument through both coils, which are in bridge over the coils of the ring-off and

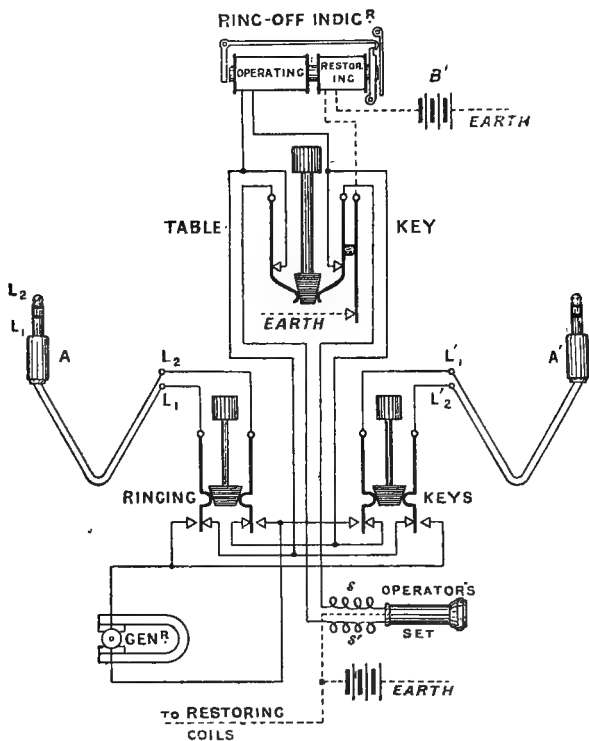

Fig. 217. Peg-circuit Connections for "Branching" System.

the subscriber's indicators. Further, the "engaged" signal is put on the calling subscriber's line at all sections. Suppose that subscriber 972 (fig. 218) is required. The tip of peg A' is placed against the test-

ring, as shown, and the passing of a current from battery *B* indicates that 972 is engaged (at *B*). Part of the current passing goes through the restoring coil of the ring-off indicator and one section of the induction coil and the receiver, so partly neutralising the other portion, which goes through half the speaking-instrument coils only. If the required line is not engaged, the communication is completed in the usual way.

It may be observed that the normal position of the table-key leaves the telephone and restoring coil dis-

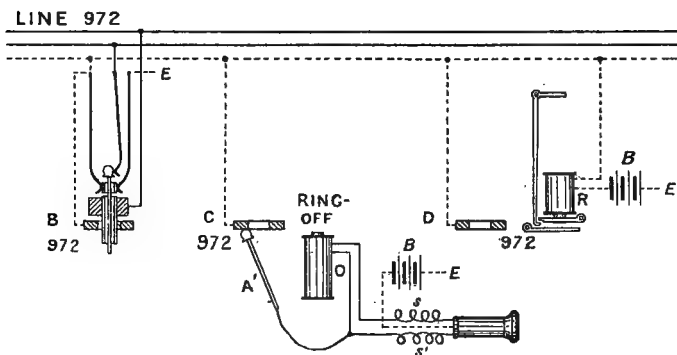

Fig. 218. "Engaged Test" Signal on "Branching" System.

connected. When the ring-off signal is given and the shutter is projected, it may be restored by momentarily turning the table-key; but the better plan is to leave it, so that projecting ring-off indicators show which pegs are not in use. The indicator is necessarily restored as soon as the peg is brought into use, because the telephone must, of course, be inserted.

The diagram of this system (fig. 217) has been made to indicate the most recent form of table and ringing keys.

CHAPTER XVII.

POST-OFFICE MULTIPLE SWITCH.

OWING to the practice adopted by the British Postal authorities when licenses have been granted by the Postmaster-General for the working of public telephone exchanges by private companies, the Department's own exchanges do not generally tend to develop as regards numbers of subscribers to such an extent as to call for the use of multiple switches. At Newcastle-on-Tyne, however, it became evident that such a system was really essential for the maintenance of the high standard of working efficiency which has been regarded as a *sine quib non* by the Department. Consequently, a metallic-circuit multiple switch was devised for this purpose, at a time when the Post Office was one of the few administrations that recognised in practice the importance of double wires; and the problem of design was yet more involved owing to the necessity of retaining the distinctive feature of the Post Office Exchange System—namely, the “permanent current” (see Chap. xiii.), which has held its ground by reason of its proved working value. Two other special provisions were also successfully secured—the first being secrecy, by means of a formation of switch-spring which effectually prevents “tapping” of a through circuit by an operator, and the

second being the prevention of "triple switching," which is more or less liable to occur on all other systems. The method by which these advantages were obtained will be explained in due course.

The switches themselves are, it must be freely admitted, not nearly so compact as those introduced by the American companies, but an improved pattern is being devised in which the compactness of the switch will receive due attention.

A full-size, partly sectional, side elevation of a switch-block is shown by fig. 219; and figs. 220 and 221 represent respectively a side elevation of the "detector"

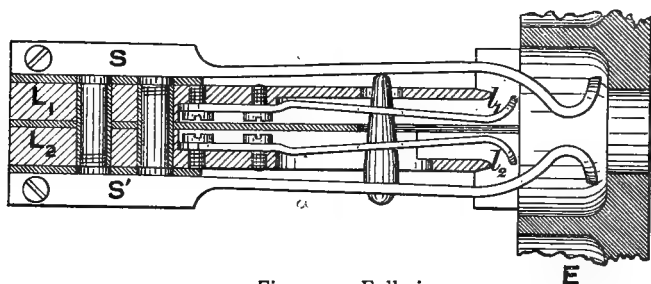

Fig. 219. Full size.

peg, and a plan of the operator's peg. The ordinary peg is similar to fig. 220, but has no insulated sections *s*.

The two plates L_1, L_2 , which form the body of the spring-block, and to which the line-wires are connected, are respectively grooved for the reception of light double springs l_1, l_2 . Above and below these two plates are the springs *S, S'*, to the lower one of which is rivetted a pin, which passes clear through a hole in the main plates, so that its end normally rests against the upper spring.

The switch-blocks are (fixed by means of two screws from the front) behind circular holes in ebonite tablets *E*,

the holes being extended vertically at the back of the tablets, as shown in the figure.

The ordinary pegs are simply connected in pairs by a two-wire flexible cord. When inserted into a switch-hole, the two sides secure a connection to each line through the cord, and also connect respectively L_1 and S and L_2 and S' , while the springs are disconnected from each other by the insertion of the peg.

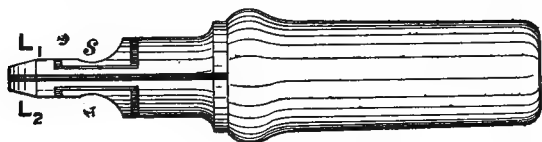

Fig. 220. Full size.

On the other hand, the insertion of a "detector" peg (fig. 220), while it gives a connection to the lines, does not alter the connection between S and S' , because a double-faced insulated section $s s$ joins them across at their front ends.

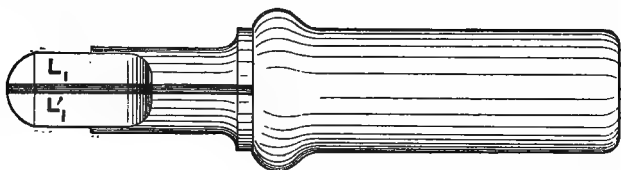

Fig. 221. Full size.

As indicated by fig. 221, the instrument or operator's peg is composed of four sections—two top and two bottom—which are joined across in pairs by the double flat springs recessed in L_1 and L_2 . A four-conductor cord is used with this peg.

The indicators used for this system are really small non-polarised relays, with long iron-cased coils wound to 1,000 ω resistance. In addition to the local

circuit arrangement, however, there is a conspicuous white needle, which is polarised by being pivoted in the forked end of a permanent magnet. This needle, which is actuated by the coils, constitutes the sole indicator for normal use as a means of calling and of indicating the state of a circuit. Shutters are entirely dispensed with, so saving the clerk's labour and time in restoring them after every call. Three positions of the indicator needle are utilised for indicating distinctive signals—namely :

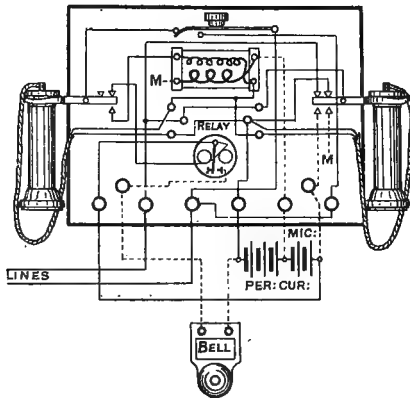

Fig. 222. Connections of Renter's Telephone.

- (1) Deflection to the *left*, which signifies "*engaged*";
- (2) Deflection to the *right*, which is the normal position, and signifies "*disengaged*"; and
- (3) The needle *vertical* or *vibrating*, which indicates that the renter is "*calling*."

The connections of the telephone by means of which these signals are automatically sent from the renter's office are given in fig. 222. To call the exchange the renter needs only to allow the left-hand switch-lever to

rise by removing the receiver (or tube) that hangs upon it. This joins the secondary coil and the receivers into the line circuit, and disconnects the permanent current battery, so that the indicator needle at the exchange is no longer deflected, but falls to the vertical or "call" position. The caller at once listens on the receiver, as the clerk at the exchange should immediately reply by speaking. In the event of delay in replying on the part of the switch-clerk, the renter is able to make the indicator needle vibrate by manipulating the left-hand lever. When the call is acknowledged the renter removes the receiver (or tube) from the right-hand switch-lever. Besides joining up the microphone circuit in the usual way, the movement of the right-hand lever restores the "permanent current," but in a reverse direction, causing the indicator needle at the exchange to be deflected to the left, and thus giving the "engaged" signal. It may be noted that fig. 222 shows a device for connecting the induction coil that has recently been introduced. The coil-ends are soldered to brass collets fixed upon the bobbin cheeks (which are square) in the relative positions shown; and the coil is fixed by means of connection screws passing through the collets into brass plates on the base of the instrument to which the permanent connections are made. As the coils are connected diagonally, the bobbin cannot be fitted in a way to give wrong connections.

The line connections for one circuit at the exchange are shown by fig. 223, which represents the connections for four sections of the switchboard. It should be mentioned that, as a matter of convenience in wiring, the lines are in all cases brought *first* to the indicators and

to the "home" or "local" switch—that is, the switch-holes of the numbers that are to be operated at that section. Further, it has not been considered necessary to duplicate the home switch-holes in the multiple panels. The diagram (fig. 223) shows that the lines are continuous throughout the switchboard, so that the continuity of the circuit does not depend upon any moving connections.

It will be seen from the figure that all the requirements of through switching are provided for quite independently of the outer springs, while the *direction* of the permanent current affords means of a simple and

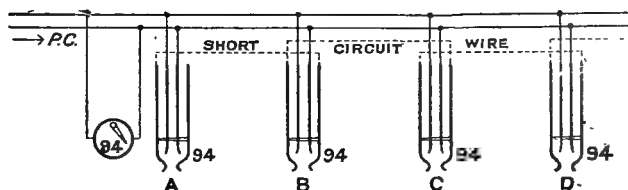

Fig. 223. Line-circuit Connections of Switch.

effective "engaged" test. The use of the "short-circuit" wire, which is characteristic of this system, is primarily to prevent *triple switching*—that is, the connection of a third renter on a circuit which is already engaged. The short-circuit wire passes consecutively from the upper spring *S* (fig. 219) of one switch-block to the lower spring *S'* of the corresponding block in the next section; and thus in the normal position forms, by means of the pins on springs *S'*, a practically continuous wire in connection with each circuit. Now the insertion of a peg at any switch-hole disconnects *S* and *S'* from each other, and joins them respectively to I_1 and L_2 , and the effect

of this change when pegs are inserted in the same series of holes at two different sections will be seen from fig. 224; the permanent current has a short-circuit between the two line-wires, so that the indicator needle goes to vertical, at once showing the operator who connected on the third renter that an error has been made. The short-circuit applies, of course, to all three lines concerned. Thus, suppose that 124 has been put through to 357 at section B, and that 246 at section C asks almost simultaneously for 124; if the clerk at section C makes the connection the result is that the indicators of all three circuits indicate "call" (needle vertical), as shown in fig. 225, and the mistake will probably be noticed and rectified by the clerk at C

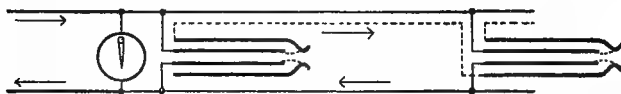

Fig. 224. Pegs inserted at same Number at two Sections of the Switch.

almost without the renters 124 and 357 knowing that the circuit has been interrupted.

A further advantage of the short-circuit springs is that, as arranged, they prevent tapping of the line-wires by the operators, and so tend to secure the privacy of communication, assurance of which is frequently of great importance to the users of an exchange. This is the object of making the short-circuit springs to project beyond the line-connection blocks.

The instrument peg (fig. 221) is made in four sections, and used with a four-conductor cord, in order to give the microphone battery the maximum amount of rest and to provide also a simple means of calling by the exchange clerk. The connections of the operator's

set, which includes a micro-telephone instrument (see fig. 175), are given by fig. 226. The microphone circuit is completed by the joining across of the two *lower* sections of the instrument peg when the peg is inserted into a switch-hole. Thus the speaking battery is joined-up only when the instrument peg is in actual use. When the button is depressed the circuit of the calling battery from the negative pole is completed by way of the coils of the relay and the two upper sections of the peg. The relay tongue is thereby moved over, which not only secures that the battery-circuit through the relay shall be maintained,

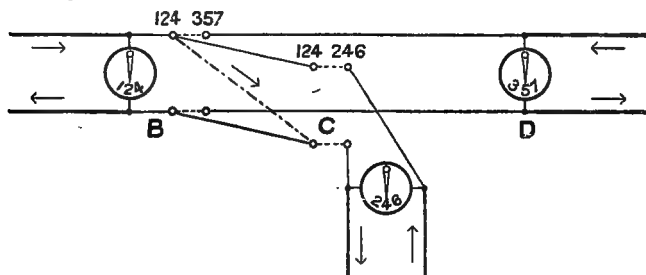

Fig. 225. Short-circuit Effect of Triple Switching.

but also closes a circuit from the positive pole of the battery by way of the right-hand upper section of the peg to line, thence through the right-hand lower section of the peg and the secondary and receiver coils (in multiple) back to the negative pole by way of the relay local-circuit. The object of this arrangement is to prevent the operator from calling by "makes and breaks," which would be a source of annoyance to a called renter on his listening in response to a call. This current remains to line so long as the instrument peg is in, but the removal of the peg permits the relay tongue to return to its back-stop.

The "detector peg" (fig. 220) is used for testing any required circuit in the multiple section. The "detector" is merely a polarised indicator relay wound to 1,000^{ohms} of precisely the same form as is used for the circuits. The insulated short-circuit stud *s* in the peg enables the detector to be brought into any circuit in bridge without breaking down the line: if the needle be deflected to the right, the line is disengaged, and may be switched through; if it be deflected to the left, the line is engaged, and the detector may be left in circuit, so that the operator may know, by the reversal of the deflection of the needle, when the line is free.

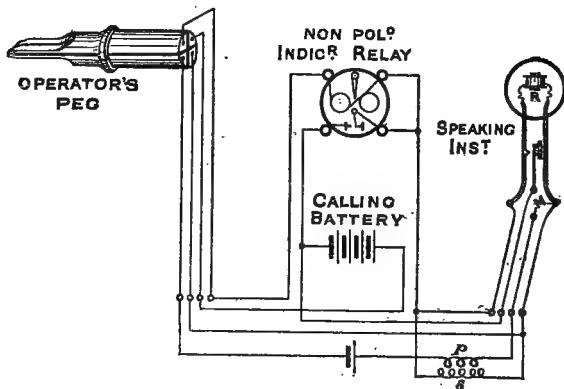

Fig. 226. Connections of Switch Clerk's Speaking Set.

It is in contemplation to combine the detector and instrument pegs (figs. 220 and 221), so as to simplify the switching and reduce the number of operations.

Where there is an intermediate office upon a circuit an exchange intermediate switch is fitted, and the connections for the terminal and intermediate offices are as shown by fig. 227.

The normal position of the switch is to EXCHANGE;

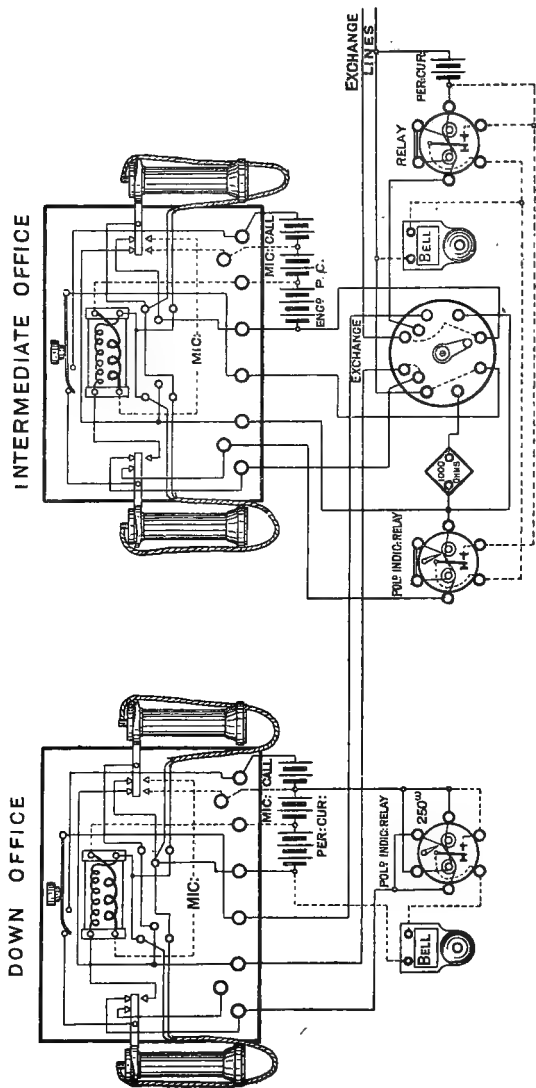

Fig. 227. Connections of Apparatus at Down and Intermediate Stations on Exchange Circuit.

in which position a permanent current is sent to the exchange from the terminal office. Either office can call the exchange by lifting the left-hand tube (or receiver), which has the effect of disconnecting the permanent current. If the terminal office calls, indication of the fact is given at the intermediate station by the reverse deflection of the polarised indicator-needle when the second switch-lever rises and the conversation begins; while if it is the intermediate office that is in communication with the exchange, the disconnection of both down wires shows the fact on the indicator-relay at the terminal office.

To call the intermediate from the down office the press-button is depressed, so augmenting the permanent current and actuating the polarised relay; while the same office is called by the exchange by reversing the speaking-instrument peg, so that a reverse current is sent to line, which also actuates the polarised relay.

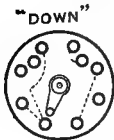

Fig. 228.

A call signal can be sent from the intermediate to the down office only when the switch at the intermediate office is turned to DOWN. The result of this change is to put an independent "engaged" current on the exchange section of the line, and to leave the down and intermediate stations free to converse. Fig. 228 shows the switch connections for this position.

The working of trunk lines is precisely similar in principle to that of ordinary renters' circuits, but the arrangements are slightly more complex, and the switch-block is modified to the extent that the end of the upper spring *s* (fig. 219) is removed, and fixed to the line-block L_1 .

A separate section of the switch is allotted to the trunk wires, at which all the renters' lines are multiplied in the usual way; but the "home switch" panel, to which the trunk wires are brought, is not in direct connection with any other part of the exchange. The switch-block and its connections for each trunk line are shown by fig. 229. Besides the alteration to the switch-block, each line is fitted with an additional polarised relay with two local contacts and wound to a resistance of 250^{ω} ($500^{\omega} + 500^{\omega}$ joined in multiple).

Fig. 229 indicates the normal position, where both

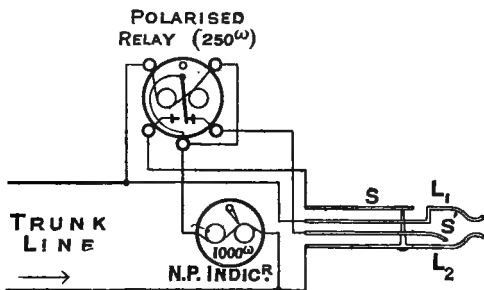

Fig. 229. Connections of a Trunk Line at the Exchange.

relay and indicator coils are in circuit. The indicator-needle is deflected to the right by a permanent current from the other end of the line. When a peg is put in at the distant switch in order to call, the permanent current is automatically reversed; the relay tongue is thereby moved to the left, with the result that (the coils of the indicator being short-circuited through the tongue, the left contact, and the springs S and L₂) the indicator-needle falls to the vertical, so indicating "call." In order to reply the operator inserts the instrument-peg, which breaks the short-circuit of the indicator coils at springs

S and L_2 ; and, acting in unison with the current from the distant station, causes the indicators at each end to deflect to the left—showing “*engaged*.” The same conditions exist when two renters are switched through by the two exchanges so long as they are speaking; but when the receivers are replaced and the permanent current is reversed, all indicator-needles deflect to the right (*disengaged*), and the operators should at once disconnect.

On this system the trunk lines are worked in both directions by the same operators (see p. 337). In-coming calls—that is, calls emanating from the further end of the trunk line—are in precisely the same position as regards putting through as the calls from ordinary renters, because the trunk-line operators have all the renters’ lines multiplied on their section. As regards trunk communications required, an operator on an ordinary section, on getting a demand for such a connection, simply informs the trunk-wire operator of the requirement (on a special calling wire, one of which is allotted to each section) specifying the calling subscriber and the subscriber at the distant exchange who is wanted. The “call” is thus transferred to the trunk-line operator, who repeats all instructions received, in order that a special “record clerk,” sitting at an adjacent table, may enter the particulars. If the required connection cannot be made immediately, owing to either the trunk line or the line of the called subscriber being engaged, it becomes the duty of the record clerk to draw attention to the fact as soon as it is likely that the required line is free.

It may, perhaps, not be unsuitable, in concluding these notes on the Post Office system, to make reference to

the extensive network of trunk lines with which the whole kingdom is now being covered. According to the scheme which is in process of being carried out, the Central Trunk Exchange of the United Kingdom will be at Leeds. All the principal places in the kingdom will have direct communication with Leeds by one or more metallic circuits; and where the prospect does not warrant the allotment of a direct line, sub-trunks from such places to a town having direct communication will be provided. By this means it is contemplated ultimately to give every subscriber to any telephone exchange the possible means of speaking to another subscriber connected to any other exchange in the kingdom.

CHAPTER XVIII.

MULTIPLE SWITCH WITH CALL-CIRCUIT SYSTEM.

A VERY simple multiple switch for metallic circuits combined with the call-circuit system has been worked out by Mr. A. R. Bennett, and has been adopted in some of the exchanges in his charge.

The lines are branched-off to the switch-sockets at each section, as in the Post Office (p. 289) and Western Electric "branching" (p. 275) systems, but in this case, of course, indicators are not used. Mr. Bennett's switch tablet¹ is shown in section by fig. 230, and the peg used is shown by fig. 231. The tablets, as will be seen, are made up of two ebonite plates, one fixed above the other, and fitted with brass sockets L_1, L_2 , to which the two lines of each circuit are brought. Each tablet provides for 100 circuits in a space $5\frac{1}{4}$ inches square. The lower holes L_2 (not necessarily the upper ones) are tapered to provide for wear of the tapered lower connecting point L_2 of the peg (fig 231). Good contact of the sleeve, L_1 , of the peg with the upper socket of the switch-hole is insured by the brass ring r , which surrounds L_1 , and is in electrical connection with it by means of a spiral spring

¹ British Patent Specification No. 19,486 (Nov. 29, 1890).

and the brass collar *c*. This brass collar screws on to the body of the sleeve L_1 , so that the spiral can be easily renewed when necessary without disturbing the peg connections. The collar serves also to fix the ebonite cover, beneath which the cord-connections are soldered to the two contacts.

The construction of these pegs seems unusually slight and fragile, but the method of their use is probably favourable to their preservation, inasmuch as the tablets are fixed horizontally, as tables, with the pegs hanging from above. This method, to which reference has already been made (p. 243), is shown in fig. 232. At the Manchester Exchange, which is fitted for 3,000 subscribers, the total length of switch-table needed is 34 ft. 8 in. This is exclusive of a separate section for trunk and junction lines. The tables are 2 ft. $1\frac{1}{2}$ in. wide, and are provided with the usual ringing keys, etc. (*K*, fig. 232). The tablets are fixed over troughs *T*, in which the connecting line wires are carried.

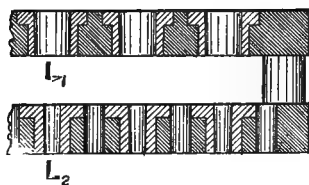

Fig. 230. Full size.

Thus the operator has both hands at liberty, and is at the same time comparatively free to move about for switching purposes without interfering with speaking facilities.

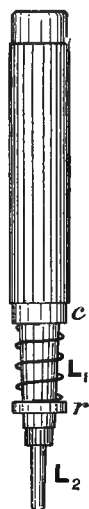

Fig. 231.
Full size.

The operators wear head-gear receivers and breast transmitters — the latter being adjustable on a small breast-plate which is hung in front of the operator.

Thus the operator has both

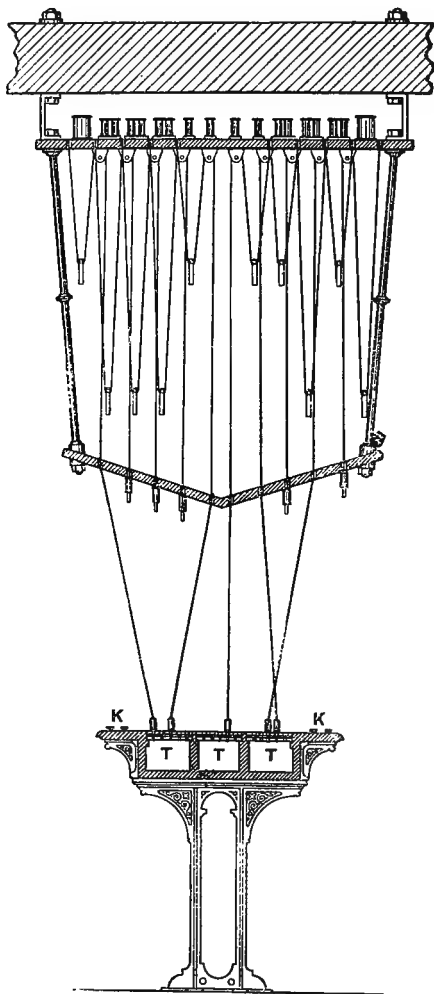

Fig. 232. About $\frac{1}{10}$ real size.

The actual method of use is shown in fig. 233, from which it will be seen that the fitting of the microphone by means of a central axis permits of the mouth-piece being adjusted with regard to the speaker's mouth. A key-switch below the microphone is arranged to join up the speaking battery by depression during short conversations; but when it is moved to one side the battery is permanently connected. This is, of course, the normal position for busy periods, while the free position, which spares the battery, is meant for times when the calls are infrequent.

The breast-plate, cases, head-spring, etc., are made of aluminium, and together, including the connection-cords, weigh only 14 oz. The mouth-



Fig. 233.

piece is of india-rubber with aluminium mountings. It is easily removable, so that each operator can have a separate one.

Fig. 234 is a diagram of the connections of a pair of pegs. The respective conductors of the two cords are connected direct, and are bridged by two exactly similar electro-magnetic resistance coils, each wound to 3,000 ω . From between these two coils the test-circuit is taken in derivation. Included in the test-circuit are a battery *B*,

the coils of a relay, and a test-thimble. The test-thimble consists of a tapering ebonite tube, split longitudinally and fitted with a brass ring by means of which it can be tightened upon the operator's little finger. The thimble terminates in a metal point to which a flexible cord-conductor is attached. The local circuit of the relay comprises a "click" battery B' , the operator's receiver, and a resistance coil of $1,000\omega$, the latter being introduced to prevent the momentary short-circuiting of the telephone,

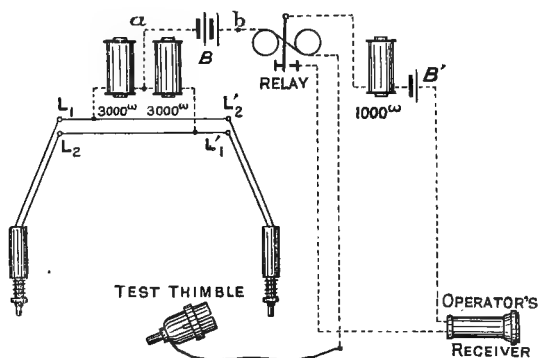

Fig. 234. Peg Connections on Multiple Call-circuit System.

which might interfere with the reception of calls. It should be understood that the test-battery B is common to all the test-circuits, one of its poles being joined at a between the electro-magnetic coils used for each pair of pegs and the other to the end b of the relay, allotted (with a test-thimble) to each operator.

The whole operation will be easily understood by aid of fig. 235. Assuming that subscriber 82 has spoken on the A operator's call-circuit and been put through to No. 197; let it be further assumed that operator B is instructed by some other subscriber to put him through

to one or other of those subscribers. The point of thimble B is at once placed against the front socket of the required subscriber's switch-hole at B's section. Now, one of the coils R is connected through L_1 with the front socket of hole 82, and the other coil is connected through L_2 with the front socket of hole 197. The result then

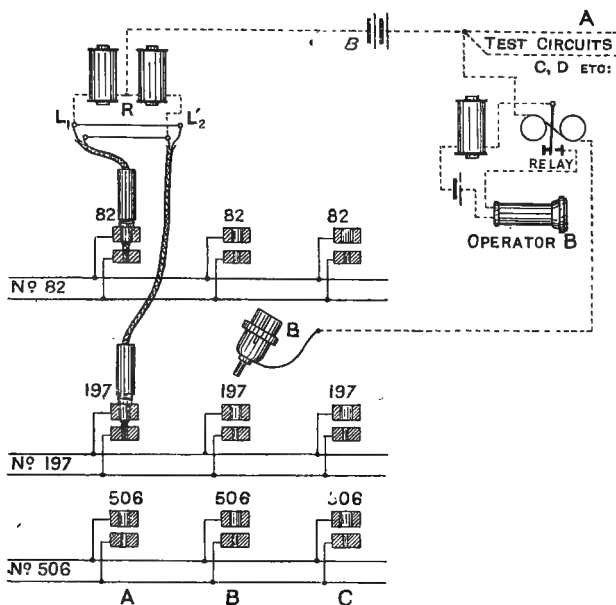

Fig. 235. Test-circuit for "Engaged" Signal.

of the point of B being brought against either of these sockets is to complete the test-battery circuit through the coils of the relay connected with the test-thimble B and one of the coils R, whereby the local "click" circuit is closed and the operator gets a very distinct engaged signal. If subscriber 506, whose circuit is free, were

wanted, no signal would be heard when the test-thimble was applied, and the through connection would therefore be completed. The subscribers, of course, do their own ringing.

The test-circuits will work equally well if condensers be used in place of the electro-magnetic resistances, but in that case the test-battery (*B*, fig. 235) must be re-

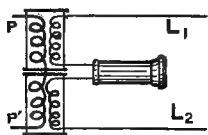

Fig. 236. Double-wound Secondary Coil.

placed by a generator or other source of alternating currents.

A further development of the call-circuit system as applied to multiple switches has been devised, but the proposed plans cannot at present be made public.

It may be remarked that in order to secure actual symmetry in the circuit arrangement when subscribers are connected Mr. Bennett has the secondary section of all induction coils wound in two parts, and the receiver coils are interposed between, as shown by fig. 236.

CHAPTER XIX.

WIRING OF SWITCHBOARDS.

ONE of the greatest of the difficulties which had to be surmounted in connection with the introduction of multiple switchboards had regard to the method of securing a convenient arrangement of the immense number of wires which have to be properly connected within so small a space as can be obtained behind the switch. The difficulty will be at once apparent when it is considered that over a surface of several square feet from twelve to sixteen secure and independent connections per square inch must be made, that the wires so connected must be arranged behind the board in such a way as will not make either the switch-strips or the indicators inaccessible, and that disturbance or "speaking induction" between this mass of wires must be carefully provided against.

The method now adopted is to form cables of elliptical shape with 25 mils cotton-covered copper wire, each cable containing 40 wires twisted up in pairs with different-coloured (or variegated) coverings. By this means, so long as the various colours or combinations are sufficiently distinct, the workmen adopt a certain order in joining up, and

any particular connection can easily be traced. The complete cable suffices for one switch-strip; and the twisted pairs for a single-wire system are used, one for the line and the other for the test wire. One reason for this is that, in the event of a single-wire system being converted to one with metallic circuits, the test-wires of the switchboards could be used as the return line (p. 268); and, in such a case, the two wires must be twisted so as to be in the best condition for preventing inductive disturbance. Used, however, in conjunction with a single-wire circuit system, such an arrangement of the wires tends to

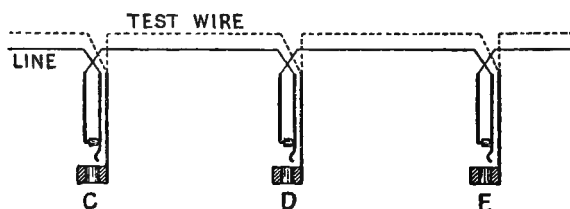

Fig. 237. Showing Pairs of Wires behind Switchboard.

minimise the induction by keeping the wires farther apart. The cables are also sheathed in lead, which is connected to earth.

The cables are run in a direct straight line from one set of springs to the corresponding set on the next section, and this is done without interfering with the practicability of getting at the strips themselves; which it is necessary to do from time to time in order to clear faults.

Fig. 196 does not quite correctly indicate the actual connections of the line and test wires; they are more clearly shown in fig. 237, from which it will be seen that there are

practically separate lengths of cable between consecutive sets of springs—one between every strip on section C and the corresponding strip on D, which is continued by another length to E, then another length goes from the multiple strip of E to the corresponding local strip (when the numbers belong to that section), then another from the "local" at E to the multiple again at F, and so on.

The actual work of connecting-up is done on a long bench, which should, if possible, be the full length of the switchboards to be connected; but if this cannot be managed, the work may be done in sections on a shorter one. Blocks (A, fig. 238) are screwed to this bench at exactly the width apart of corresponding strips of the switchboard. A switch-strip is then screwed to each of these blocks, each strip bearing the same numbers. Behind the strips, at a varying distance (the shortest being $1\frac{1}{4}$ inch) is fixed a regulating block B, on the top of which are cut slots which correspond with the spaces between the switch-holes, and midway between the slots (and so corresponding with the centres of the switch-holes) are twenty pegs projecting from the back edge of the block. At each end of these regulating blocks are screwed clamps, C, for holding the cable.

The cable is cut into lengths sufficient to reach from the extreme left-hand spring of one strip round the end peg of the regulating block to the next block on the right-hand side, and round its extreme right-hand peg to the last spring on the strip, allowing about half an inch extra for soldering. When this is done all along, opposite each strip are the ends of two cables—one running to the right and the other to the left. The

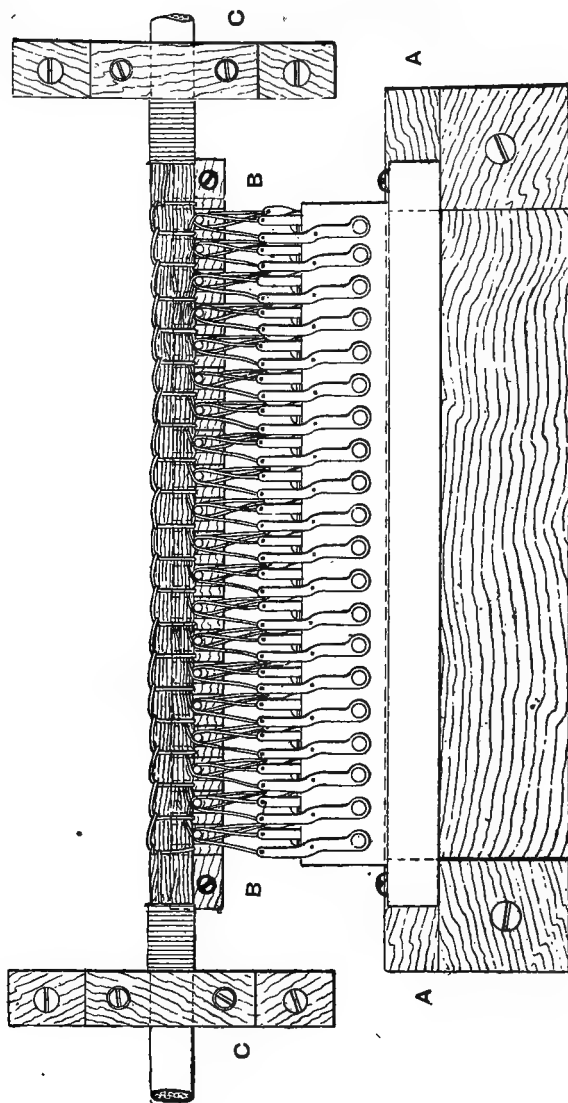

Fig. 238.

lead and other outer covering is next stripped from each end of the cables, until the unstripped portions reach to the clamping blocks, in which the cables are then fastened, so as to lie straight between each section.

Standing in front of one of the blocks, the workman takes a pair of the wires from the cable on his left-hand side, bends them round the extreme right-hand peg, untwists the covering from the ends until the covered portion just reaches to the right-hand spring of the strip, and then threads one wire through the hole in the test-wire connection-strip (T, fig. 192), and the other through that in the line-spring L. This is repeated until the whole of the line-springs and test-strips have each a wire attached. The end of the right-hand cable is now taken, the wires bent round the pegs in a similar manner, and connected one of each pair to that test-wire strip which already has on it a wire of the same colour, and the other to the corresponding contact-stud strip *l* (fig. 192). It will be seen that each of the test-strips thus has two wires attached, one from the left and the other from the right hand cable. The wires are next all soldered to the strips and springs, the loose ends cut off, and the wires at the back of the regulating blocks bound together by tape or covered wire (which can be threaded through the slots in the block), so as to form as it were a continuous cable with wires projecting therefrom to the spring-strips. The same process is repeated at each of the blocks along the bench, except that it is advisable to test half the connections as they are made, so as to ensure that corresponding springs shall be connected to each other throughout the length.

When all are so connected and finished-off, the strips

are unfastened from the blocks on the bench, the cable lifted off the regulating pegs, carried behind the switchboard, and each of the strips screwed in its proper position on the board.

The connections of the rest of the cables vary only from that described in the distance allowed between the strips and the regulating blocks when fitting up on the bench. The connecting wires for each panel of a section are of the same length, so that in the ordinary arrangement of a multiple switch (with six panels at each section) there are six different lengths. On the

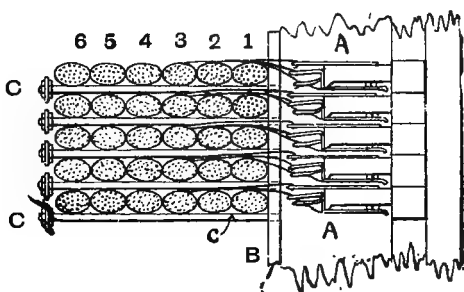

Fig. 239.

Manchester board, for instance, the shortest length is $1\frac{1}{4}$ inch. The cables with this length of connecting wire are for the strips fitted in the first panel of each of the sections, those for the second panel have a length of 2 inches; those for the third, $2\frac{3}{4}$ inches; for the fourth, $3\frac{1}{2}$ inches; for the fifth, $4\frac{1}{4}$ inches; and for the sixth, 5 inches, thus lengthening by $\frac{3}{4}$ inch for each panel to the right.

By adopting this plan the cables when in position lie in horizontal layers, as shown in the section, fig. 239, which also shows the arrangement connected to the

boards for supporting the cables and keeping them in position. Between the panels are fixed dividing boards A, screwed to the edges of which are steel bars B, drilled and tapped for the steel pins C, which are threaded at each end and fixed at a distance apart equal to the thickness of the switch-strips. Upon the lowest of these pins six cables are arranged, one behind the other, the first being connected to the lowest strip in the first panel of each section, the second to the lowest strip in the second panel throughout, and so on. The second row of pins is then screwed into position and the second layer of cables placed, more pins being put in as layers of cable are added above. In this manner a very neat and compact mass of cable is obtained, out of the way of any other part of the boards.

In order to reach any of the strips on which a fault has developed, a few of the steel pins are unscrewed above and below its position to right and left, when an opening can be made between the proper layers large enough to unscrew and withdraw the strip. Having cleared the fault, the strip is re-inserted, fastened, the pins refixed between the layers, and all is straight again.

An even more effective contrivance for cable racks, the design of which is due to the ingenuity of the London engineers of the National Company, is shown in fig. 240. In this case the strip B is of angle-iron, with its projecting arm drilled and tapped transversely at distances equal to the thickness of the switch-strips. Into these holes pass shouldered screws, which act as pivots for the arms C, twisted near their axis so that their flat surface is uppermost, and fitted with two spacing-pins. On these arms the cables are placed,

and each arm rests upon the projecting pins of that below it. When, however, it is desired to get to a strip, all that is needed is to lift two arms on each side of the particular panel in the row immediately above the strip required. Special pins, as at A, are used for holding two arms the necessary distance apart.

In fig. 196 the connections of the "local" springs are shown as being made in their proper position consecutively with the general springs of the same numbers upon their own section. This plan is not

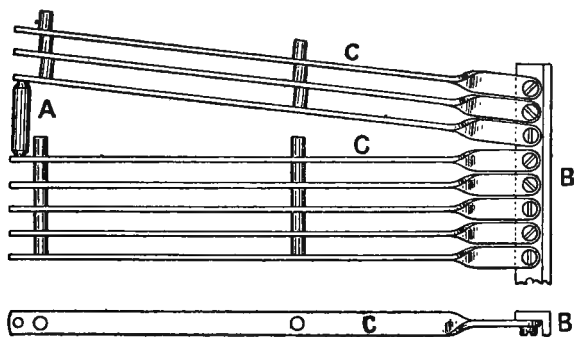

Fig. 240. $\frac{1}{4}$ full size.

invariably adopted, on account of the inconvenience of taking the cables out of the direct line for such strips. The alternative plan is to run the cable direct to its proper strip in the "multiple" portion only of each section, and then to take it back through the "local" springs to the subscribers' indicators. The objection raised to this plan is that, inasmuch as only that portion of wire in the exchange is cut out of circuit that is beyond the switch-hole used, the whole length of cable is invariably in circuit when the local springs

are used, and these should generally be used at their own sections. By joining them up consecutively with the multiple springs this extra length of cable—at least twice the total length of the board for section A—is invariably cut out. On the other hand, it is objected that the plan of taking the "locals" in consecutively takes the cables out of line and necessitates a special cable, whereas if difficulty in any particular cases should arise from the extra length of cable, it can be readily eliminated by the use of the "multiple" switch-holes in lieu of the "local." As a matter of fact, operators frequently in practice do use the "multiple" holes in preference to the "local." However, where, as at Manchester, the consecutive connection plan is adopted, it is effected by the use of a very thin cable, in which the wires are silk-covered instead of cotton and rubber covered for the two lengths of cable which go to the "local" strips. There is, however, a further practical objection to the consecutive connection, and that is that the "local" springs cannot be redistributed, as is sometimes desirable (see p. 325).

CHAPTER XX.

TEST-BOARDS, ETC.

THE leading-in and orderly arrangement of the line-wires between the outside line and the switchboard is a matter of great importance. With a large number of wires brought in to one point some simple method of identification and tracing for testing purposes would be essential in any case, but when the ultimate connection of each wire is liable to be varied at any time, as it is in the case of telephone subscribers' lines, the need is distinctly accentuated.

One of the earliest methods adopted, and still used because of its simplicity and economy, is shown diagrammatically by fig. 241.

The cables from the outside are led into the building and to the test-rooms (which should be situated as near to the switch-room as possible), and connected to the terminals of the *test-board* in regular rotation as regards the numbers that the wires bear on the poles or in the cables. A very efficient way of leading-in and of keeping the cables separate is by arranging a series of iron grids, both vertically and horizontally, across the general direction of the cables. The cables can then be

threaded through such of the reticulations in these grids as will bring them to their required position with regard to the test-board. The test-board itself, with the distributing board, is practically a partition placed sufficiently clear of walls on either side to leave proper space for working. Double terminals are fitted on both sections—the *test-board* and the *cross-connecting* or *distributing board*.

The incoming cables and the cables which go to the switch-board are connected on one side to the terminals of the test and distributing boards respectively, and the necessary cross-connections between are made on the other side of the partition. It will be clear that the cables to the switchboard must be taken in regular rotation, and it is obviously convenient, where possible to have the distributing-board so arranged that one row of terminals shall serve for the connection of a complete cable. This is indicated in the figure.

A cross-connection is taken from the test-board terminal through a gap in the side of the cross-connection trough (sufficient for the whole number of wires from each row) and along the trough until it is opposite its proper number on the distributing-board, then through a gap in the other side of the trough, and to its proper terminal.

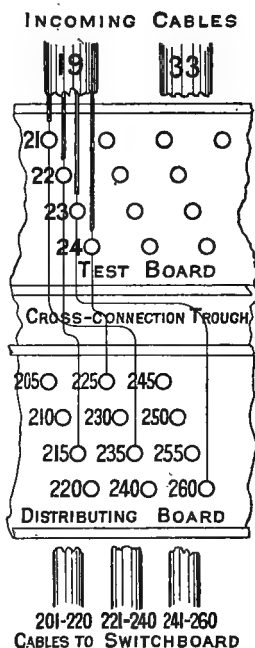

Fig. 241.

In this way, for instance the line of a subscriber, No. 225, whose outside wire is numbered 24 in cable 19, is brought into its proper numerical position for connection to the switchboard cable 221-240. The arrangement and spacing of the terminals is a matter of individual practice, depending upon the number of lines to be accommodated, the possible form of the test-board, etc.

This arrangement, however, although very simple, is not by any means the most convenient that could be desired. When a test has to be made, it is necessary to take off a wire and clamp the testing-instrument wire in its place, and this practice is very apt to lead to disconnection faults, either from breaking of wires or from loose terminals.

The telephone engineer generally in these days likes to make sure of all connections, as far as possible, by soldering, or at least by screwed connections that do not need to be disturbed in any ordinary circumstances.

The space required is also an element against this plan; compactness being generally of very great moment in fitting up a large exchange.

With a view to the removal of these drawbacks various other systems of test-boards have been devised. One plan, largely used in the United States, and adopted at Manchester and many large Continental exchanges, is described below.

The test-board is divided into panels, each of which is again subdivided into ten strips, part of one of which is shown in figures 242, 243, 244, and 245, which are respectively front, back, side, and end elevations. Each of these strips is complete in itself, with lightning-protectors, testing springs, and cross-connection trough; and when they are fixed side by side other troughs are

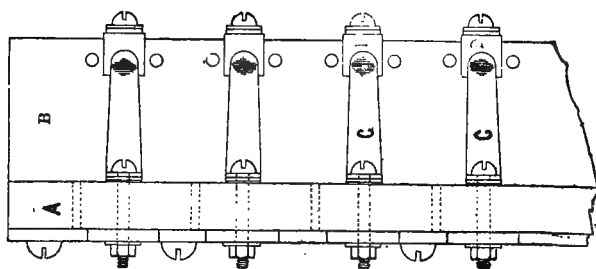

Fig. 244. $\frac{1}{2}$ full size.

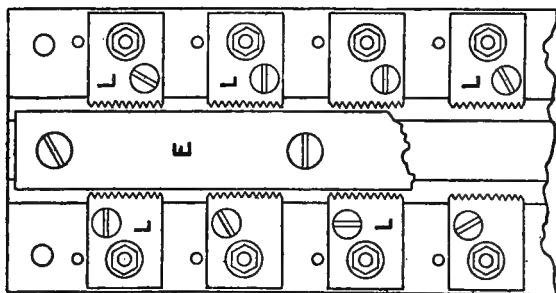

Fig. 243. $\frac{1}{2}$ full size.

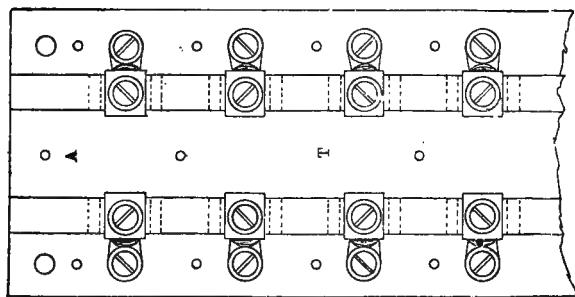

Fig. 242. $\frac{1}{2}$ full size.

formed on each side, as indicated in fig. 245. Referring to the figures, A is a piece of ebonite 26 in. long by 3 in. wide and $\frac{1}{2}$ in. thick, to one face of which are fastened two other blocks of ebonite of the same length and $1\frac{1}{2}$ in. wide by $\frac{3}{8}$ in. thick; these together form the channel or trough T, through which the wires are led. On the other face of the block A is screwed a wide brass bar (E, fig. 243) on each side of which, at a distance of $1\frac{1}{4}$ in. apart, are fixed brass plates L, one edge of which is serrated and adjusted very near to, but not touching, the centre strip, which is connected to earth. One of

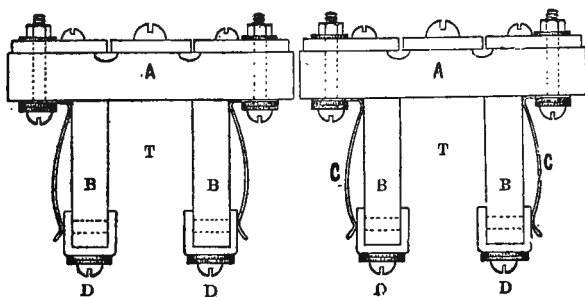

Fig. 245. $\frac{1}{2}$ full size.

the screws which fix the serrated plate passes through from the front, where its head clamps the end of a bent brass spring C. The other extremity of this spring bears against a brass plate, D, provided with screw and washers, and fixed on the edge of the projecting block B.

Part of the *distributing-board* is shown in figs. 246 and 247. It is simply a series of small brass plates, with screws and washers, fitted on an ebonite plate; to which the wires of the cables from the switchboards are brought and soldered in regular numerical order. The screws and washers are used to clamp the ends of the

cross-connecting wires which complete the connection between the cables on this board and the wires on the test-board.

The manner of joining up the wires on these two boards, in order to keep all regular and tidy, will be

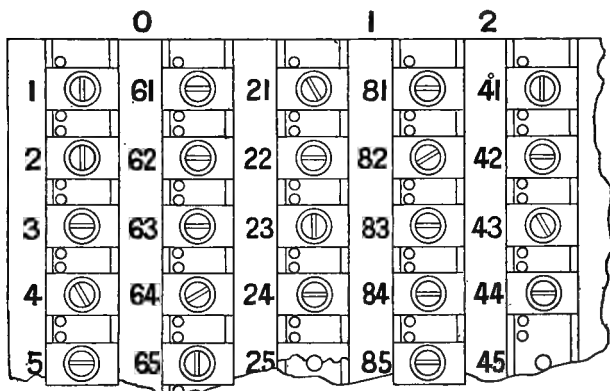

Fig. 246. $\frac{1}{2}$ full size.

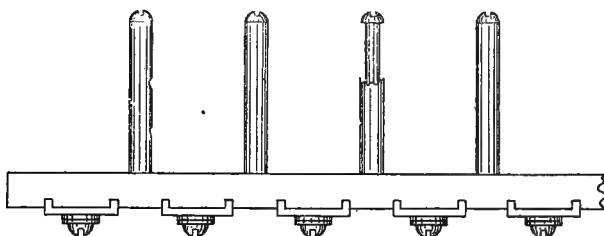

Fig. 247. $\frac{1}{2}$ full size.

readily understood from the diagrams and the previous description.

All wires from the outside are brought through the main trough, and to any convenient trough T (fig. 245). Each wire is then threaded through one of the holes

shown in B, beside the plates D, and fixed between the spring and washer of the corresponding lightning-protector screw, which is thereupon screwed up when the plate L has been properly adjusted as regards the earth-strip E.

These wires are joined to consecutive terminals, the first that are vacant, without regard to the numbers of the subscribers they are connected to.

The cross-connecting wires are now attached to the screws D on the front of the board, and run up the small troughs, at the end of each of which is a vertical row of holes. Through which of these holes the wire shall pass depends upon the number of the subscriber to which that particular line is connected. For instance, the cross-connecting wires for all subscribers between 1 and 300 may pass through one of the first holes from the bottom; those for numbers between 300 and 600 through one of the second holes from the bottom, and so on, rising one hole higher for every three hundred in the number of the subscriber.

The wires, after passing through the holes, are carried horizontally behind the test-board, and round to the top of the front face of the cross-connecting board, then down through one of the holes at the top of the latter board, which is over the proper vertical row of terminals, and so down the back of this board through a hole in the ebonite to the terminal which bears the subscriber's number. The wires are guided along their course and kept in position by brass pegs covered with ebonite tubes, as shown in fig. 247.

To illustrate the whole system, let it be supposed that the wires from a certain district are brought to the central office in a cable of, say, twenty wires. These will first be taken through the trough on to the test-

board and attached to the first twenty spare terminals, although the numbers of the subscribers to which their run may be very far from being consecutive. Separate cross-connecting wires are then run to the terminals which bear the subscribers' exchange numbers on the distributing-board. All this can be easily done without disturbing any of the wires already connected. Or perhaps a subscriber, No. 158, changes his address to such a distance that a new wire is required to be run: the leading-in wire for this is run on to the test-board and attached to the first spare terminal, the old cross-connecting wire is detached at both ends and pulled out, and a new one run between No. 158 on the distributing-board and the new position on the test-board. The old lead is left on its terminal on the test-board and again brought into service when the old line is utilised for another subscriber. Thus any change made in the outside wires is corrected by running new connections between the two boards.

It is necessary to keep a record of the positions of the wires on the test-board, in order to be able to find any subscriber's wire thereon without trouble. This is effected by keeping a book in which two separate lists are posted. The first is the subscribers' list, opposite each name in which is entered in an adjoining column the number on the test board to which the corresponding wire is attached. The second is a list of the test-board numbers, having in an adjoining column the subscribers' numbers whose wires are attached. There is also an additional column for the record of any changes that are made.

The utility of the springs C is in regard to the facility which they offer for the testing of the lines, etc. The

testing instruments are connected by flexible cords to pegs, which are simply pieces of ebonite faced with brass and fitted with a connection screw. By inserting a peg between C and D (fig. 245) so that the brass face comes in contact with the spring, the testing instrument is at once connected to the subscriber's line which is joined to that spring, and any necessary test can be made. By reversing the peg the testing set is similarly connected

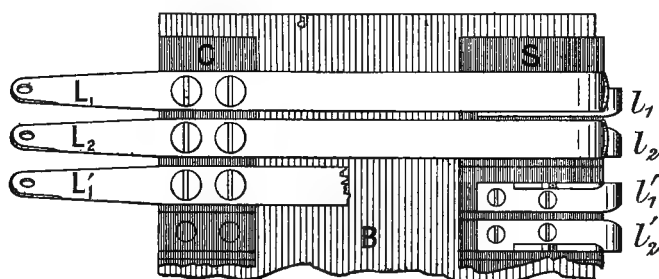

Fig. 248. $\frac{1}{2}$ full size.

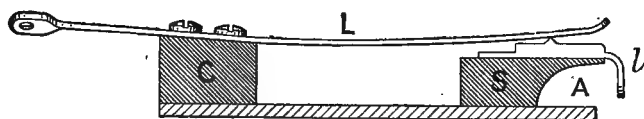

Fig. 249. $\frac{1}{3}$ full size.

to the internal portion of the same circuit—the distributing-board, switchboard, etc.

By using a peg with brass faces on both sides and a two-wire flexible cord, a telephone or other instrument may be inserted directly in circuit with any line without interfering with its working.

A very neat and compact form of board, designed for use in connection with the London trunk-wire system,

has been devised by the engineering officers of the National Telephone Company, and a description of this will serve to illustrate a metallic-circuit system. Part of a test-board strip is shown in plan and section by figs. 248 and 249. Each strip consists of a base-plate of sheet-iron, B, upon each edge of which is fixed a strip of ebonite. Upon the ebonite piece C are fitted twenty pairs of springs L_1, L_2 , which normally rest upon points projecting from the brass plates l_1, l_2 fitted upon the channelled ebonite strip S. The springs L_1, L_2 are for the connections to the outside lines, and the contacts l_1, l_2 serve for the connection of the wires from the switch-board cables. Each strip serves for the lines connected with a multiple switch-strip by one cable, which is brought up the channel A.

Here it may be remarked that the plan adopted in this case is to make the cross-connection between the line-wires and the test-board, instead of between the test-board and the switchboard. There is at least one advantage in this plan, and that is that the numbers on the test-board are then the subscribers' numbers in regular rotation—instead of being merely the outside wire numbers with little systematic arrangement.

The test-strips slide vertically in racks at the lower part of the test-cabinet, which is made as a separate and independent structure, so that it may be easily moved if required. The whole arrangement of the cabinet is shown in transverse section by fig. 250. Above the cabinet are ranged small serrated protectors in vertical rows of twenty-five pairs, each pair occupying a vertical length of 1 inch. Thus, one vertical row provides for all the connections from a 50-wire

cable. The connections from the outside cables are soldered to the protector plates. A second connection

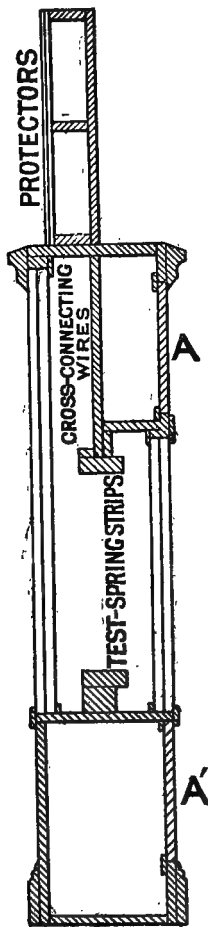

Fig. 250.
About $\frac{1}{10}$ real size.

—the cross-connecting wire—is made to each plate by means of a detachable tag to which the wire is soldered. This wire passes through the space for the cross-connecting wires at the left-hand upper part of the cabinet, and so to its proper spring upon one of the test-strips. The switchboard cables are taken up through the space on the right-hand side of the cabinet, and so led to the switchboards. The shutters on each side of the cabinet are made to slide. The upper panel A is removable; as is also the lower panel A', so as to provide for cases where the switchboard cables are led downwards.

In describing the general arrangement of the local switch-springs on multiple boards, it has been tacitly assumed that they are apportioned to the several sections strictly according to their consecutive numerical order. Now, although the actual operation of switching through a calling subscriber is not affected either way by the required subscriber being upon the same "local" section or not, it is nevertheless sometimes desirable to depart from

the consecutive numbering for the local springs. That there is no practical objection to such a departure will be at once evident on consideration that on receiving a call the operator has only to connect to the corresponding switch-spring, irrespective of the actual number. The desirability of departing from the regular order arises when it is found that a large number of the subscribers allotted to any one section are busy correspondents with the exchange. Such subscribers need to be distributed

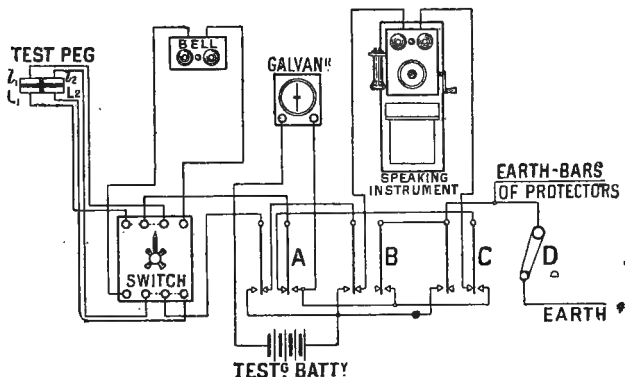

Fig. 251. Connections of Testing Instruments at Test-board.

between the different sections, and in order to facilitate this operation *intermediate distributing-boards* are often used. Instead of connecting the local switch-springs consecutively with the multiples (fig. 196), the multiple springs are first connected throughout, and the lines are then brought to the terminals of the intermediate board. It is evident that from here, on the cross-connection principle, any series of multiple springs can be terminated at any local spring and indicator upon any section. Thus the subscribers can be allotted to any section irrespective of their numbers.

Some other forms of test-boards, etc., have been introduced, but as their essential features are not materially different it is scarcely necessary that they should be described.

As regards the actual method of using a test-board for testing purposes, it may almost be said that every telephone engineer has his own system. For illustrative purposes, however, it will suffice to describe the plan adopted by the National Company at the Central Exchange in connection with the test-board described above (p. 322, figs. 248 to 250). The testing-set (fig. 251) consists of a speaking instrument, an extra mag-



Fig. 252. $\frac{1}{2}$ full size.

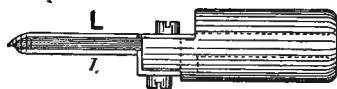

Fig. 253. $\frac{1}{2}$ full size.

neto bell; a vertical galvanometer detector); a three-position switch; three "table keys," A, B, and C; a two-way switch, D; and the testing battery; all of which are connected as shown and used in conjunction with a four-

wire cord, terminating in a four-sided test-peg. This peg is shown in plan and side elevation by figs. 252 and 253, in which the metallic connections are lettered to correspond with the springs and blocks in figs. 248 and 249, to which connection is made when the peg is placed in any line-circuit. When the test-peg is thus placed in circuit on a line and the switch is in the central position as shown, the speaking instrument is placed in bridge across the metallic loop. The turning of the switch to the "left" and "right" changes the connections to those shown in fig. 254, and joins the

speaking instrument, etc., respectively to the exchange side and to the line side of the loop, the other side being at the same time joined to the extension bell.

In either position of the switch, turning table-key A disconnects the instrument and puts the galvanometer and battery in circuit. This forms the test for continuity and short-circuit.

Turning key B joins one side of the battery to line 2 (L_2 , l_2 , or both, according to the position of the switch) and one side of the galvanometer to earth, thus affording a test for "earth" on line 2. Turning key C provides in the same way an earth-test for line 1.

Although theoretically the loop should be disconnected at the further end for these earth-tests, practically the differing deflections indicate sufficiently which wire is faulty. If a wire is found



Fig. 254.

to indicate an earth-fault, switch D (which puts "earth" on all the earth-bars of the protectors) is momentarily turned to the right. If the current is still on it proves that the fault is in the protector.

When more sensitive tests are to be made, it is necessary to disconnect the line at the lightning-protector and make the connections direct.

For some smaller systems it is convenient to be able to make office-tests from the table of the officer in charge of the exchange. For switches of the form illustrated in fig. 140 this is sometimes effected by means of a special test-peg (fig. 255), which by a three-wire cord makes separate connection with each of the points L, T, and l ,

so enabling the testing officer to make any connection required. The point l' is pressed forward by a spring

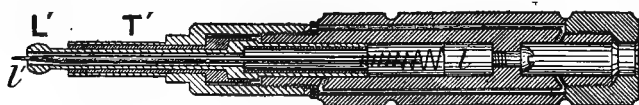

Fig. 255. $\frac{3}{4}$ full size.

which is shown in the figure, and which is soldered to the small cylinder l , through which connection with the cord-conductor is obtained.

PART V. .
MISCELLANEOUS SWITCHING AND
OTHER SYSTEMS.

CHAPTER XXI.

TELEPHONE TRANSLATORS OR TRANSFORMERS.

WITH the spread of telephonic communication within the area of every city and town of any importance, there has arisen the demand for connection between the different systems, so that a telephone system must provide means of communication for the subscribers with the systems of as many other towns as possible.

Now, these connecting, or *trunk*, lines are often of considerable length, and, if they were to be worked as single wires, induction would almost inevitably render communication difficult, if not impossible. When there are only a few wires, "cross-talk" is quite plain, and, with a large number of lines the increased disturbance renders communication hopeless. The only known method of getting over the difficulty is by the employment of double wires. If, however, double lines are used for the "trunk" connection between two distant central stations, must the lines of all the subscribers using the trunk lines be constructed double also? On some systems such a necessity would have very seriously in-

terfered with the extension of trunk wires ; as, although the desirability of using two wires in all cases is now generally admitted, the transition from single to double lines must, of necessity, be more or less gradual. However, the application of transformers, or translators, at the ends of a double line between two central stations renders it possible for a subscriber connected by a single line with one distant central station, to enter into communication through the double trunk wire with any subscriber connected to the other station.

Such arrangements were first introduced by Mr. A. R. Bennett¹ in 1881, and since then they have been in very considerable use.

As ordinarily used, translators are merely induction coils of special construction. The ordinary induction coil, having a primary of small, and a secondary of large resistance, would not do: both the circuits must have a comparatively high resistance, as each operates alternately as primary and secondary, according to the direction of the speaking. The general experience, however, is opposed to equal winding, as it is found advisable to have a higher resistance—that is, a greater number of convolutions—upon the trunk section than upon the local subscribers' single-line section of the translator. The proportion adopted by the National Telephone Company is 290° for the trunk and 140° for the local sections. The core must be of the softest iron wire, and, to obtain the best results, the coils must be wound as closely as possible and with the greatest regularity. The two sections are wound in alternate layers. The cores in the most approved form are rather more than double the length of the coils, and when

¹ British Patent Specification 4,428 (October, 1881).

the winding is complete the projecting ends of the soft-iron wires are spread out and folded back over the coil to overlap, so as to form a complete magnetic circuit. A translator of this pattern—the Liverpool—as made by many companies, is illustrated by fig. 256.

This translator is also capable of repeating the magneto call currents, so that, if desired, ringing through can be resorted to.

The introduction of a translator leads, as might be expected, to a somewhat serious loss of effect, so that it is most desirable to restrict the number to two as a maximum. The regulations of the National Telephone Company for the London district are made with a view to having not more than one translation. With this object it is ruled that no two single-wire subscribers are to be put through on a trunk wire—one of two correspondents must have a metallic circuit.

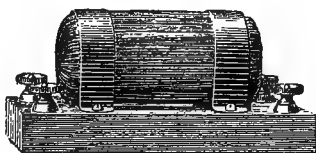

Fig. 256.

Inasmuch as with any ordinary pattern of switch-spring the necessary indicator at each end of the trunk line must be in direct circuit with the trunk section of the translator, and not in derived circuit, it is very desirable to eliminate it altogether if possible, as it injuriously affects the speaking. This has been effected by the invention, by Messrs. Coleman and Jackson, of a combined indicator and translator. It is a single-coil iron-sheathed indicator, of much the same general form as the Western Electric ring-off indicator (which it preceded), except that, of course, the coil is wound with two wires. The armature (which is at the front end) is pivotted very

near the end of the coil; it is counterpoised by an adjustable weight, and its range of motion can also be adjusted. A detent on a horizontal rod attached to the armature serves normally to hold up the indicator-shutter.

One system of connections for use with this combined indicator and translator is shown by fig. 257. The object of taking the circuit through a metallic-circuit switch-

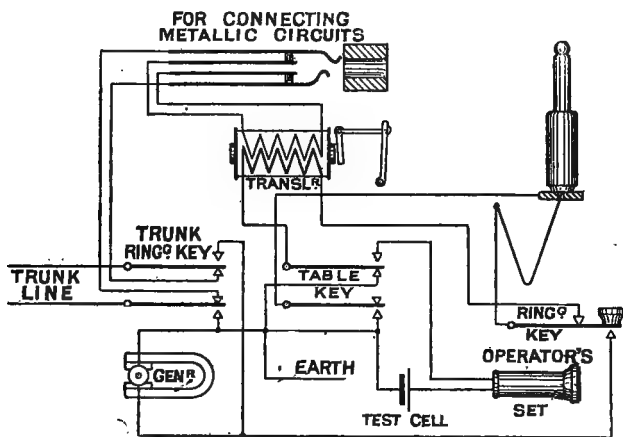

Fig. 257. Trunk Line Connections with Coleman-Jackson combined Indicator and Translator.

spring is to provide means of disconnecting the translator circuit when the trunk line is required to be switched through to another metallic-circuit trunk or otherwise. The ordinary ring-off indicator belonging to a pair of double cords is then brought into circuit in derivation. It may be remarked that the single-wire section of the translator is normally disconnected, as the completion of that circuit materially reduces the sensitiveness of the indicator. The peg in connection with the table

and ringing keys enables the operator at the trunk line to switch on to any multiple single line, put it through to the particular trunk line, and call, speak, etc. Speaking between the operators at each end of the trunk line is effected through the translators.

In Germany Mr. Elsässer adopted a plan of applying a translator at one end of the trunk line only, as shown diagrammatically in fig. 258. The simplification, however, can scarcely be considered of much advantage, as, although the effects of induction are neutralised if the lines between A and B are properly twisted, the earth connections are sure to admit disturbing earth-currents, etc., which would almost always be more difficult to meet than the reduction in volume of sound when two

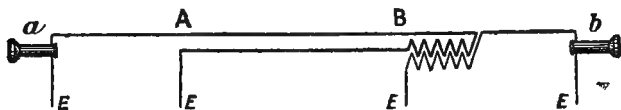

Fig. 258. Elsässer's Plan.

translators are in circuit. The system has, however, proved very satisfactory where it has been applied.

"Ringing through" where voltaic currents are used is a somewhat complicated matter, as two relays are required in addition to the translator. The usual connections for this requirement are shown by fig. 259. The circuit of line 1 is made through the tongue and back-stop of relay B, the primary coil of the translator, the coil of relay A, and so to earth or return line. Line 2 passes through the tongue and back-contact of relay A, the other coil of the translator, the coil of relay B, and so to earth or return wire. The front-stop of each of the two relays is connected to one pole of the ringing battery. Hence when a current is sent from

line 1, relay A is actuated and a current passes to line 2; while a current sent from line 2 is translated on to line 1 through the action of relay B.

The working of a mixed system of metallic circuits and single wires where translation is necessary (see fig. 164 for the simpler circumstances) presents a problem that is by no means easy of solution. A really admir-

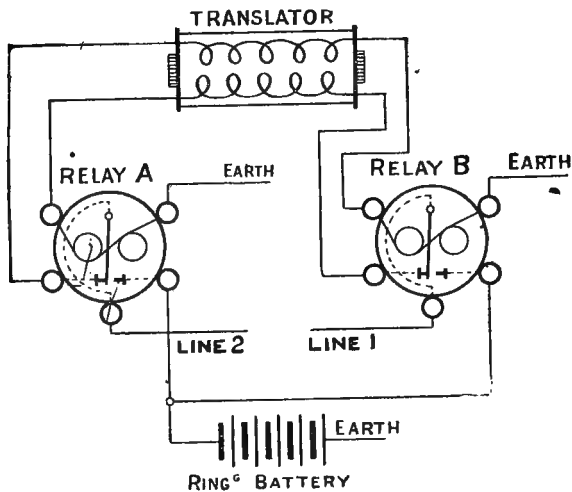

Fig. 259. "Ringing through" a Translator with Battery Currents.

able method has been adopted by the National Telephone Company in connection with the trunk-line system of the London District. The *junction*, or *sub-trunk*, lines which connect the various exchanges with the "Central" in Oxford Court may be either single or metallic—the process of conversion to metallic throughout being gradual. The main trunk lines—those connecting with the various provincial exchanges—are invariably metallic. There are, of course, sub-trunk lines between most of

the various sub-exchanges direct, but not between all, and, even where direct communication is provided, pressure of business and other reasons occasionally necessitate the switching through of one sub-exchange to another by way of the "Central." Now the general practice is to divide the lines between the Central and each sub-exchange into outgoing and incoming—working them upon the "up" and "down" principle. Thus, if there be twenty-four lines between Oxford Court and Coleman Street, twelve are used exclusively for communications arising at Coleman Street, and the other moiety for connections originating at the Central. At all exchanges the *outgoing* wires are "multiplied" at each section of the board, but the *incoming* lines simply terminate in a peg at one section only. Similarly on each sub-trunk route there is an incoming and an outgoing speaking wire, the outgoing wire being multiplied at each section as for the outgoing sub-trunks, and the incoming terminating in an operator's set, at which the operator is constantly listening.

As regards the working at the sub-exchanges the system is quite simple. The subscriber's lines are practically all single, so that the secondary wire of a Liverpool translator is inserted in each metallic circuit sub-trunk, and the primary wire multiplied up as the outgoing line at the switch. For single-wire sub-trunks the connections are normal.

The speaking circuit is a single wire, and the multiplied switch-holes of the outgoing wires are practically only test-blocks, against which the operator presses the end of the speaking-peg while speaking to the operator at the other end. For incoming circuits the listening operator's instrument at one section terminates the speaking

circuit, taking the place of the simple peg and cord on the incoming sub-trunk lines.

The requirements at the Central Exchange, however, are considerably different and more complex. A given single-wire sub-trunk may require connection either to another single-wire line or through a translator to a metallic loop; and conversely, a double-wire trunk or sub-trunk may be connected at one time to another double-wire line, and then to a single wire through a transformer. Now it is evidently impossible for the operators to distinguish between these several requirements by a consideration of the actual conditions, and hence the following ingenious expedient is resorted to.

As already stated, every incoming line is brought to one section only, and terminates in a peg; and this peg will, of course, be single or double according to the circuit. The two kinds of circuit are distinguished by the cord for single-wire circuits being *red*, and for double wire circuits *white*. Every outgoing line is multiplied through the switch *twice* at most sections, as shown in diagram by figs. 260 and 261. The former shows the connections for a metallic-circuit trunk or sub-trunk, and the latter those for a single wire sub-trunk. With this arrangement the only instruction needed for the operator is that white-cord pegs go in the lower and red-cord pegs in the upper series of holes. Suppose, for instance, the operator at section B hears on the speaking wire "Coleman 8 through to Liverpool." On taking up peg "Coleman 8" it is seen to have a white cord, and is therefore inserted in the lower switch-hole "Liverpool 1," that station being advised as to the required connection by the originating operator. If the call had been for "Woolwich" the peg would still have been placed in the

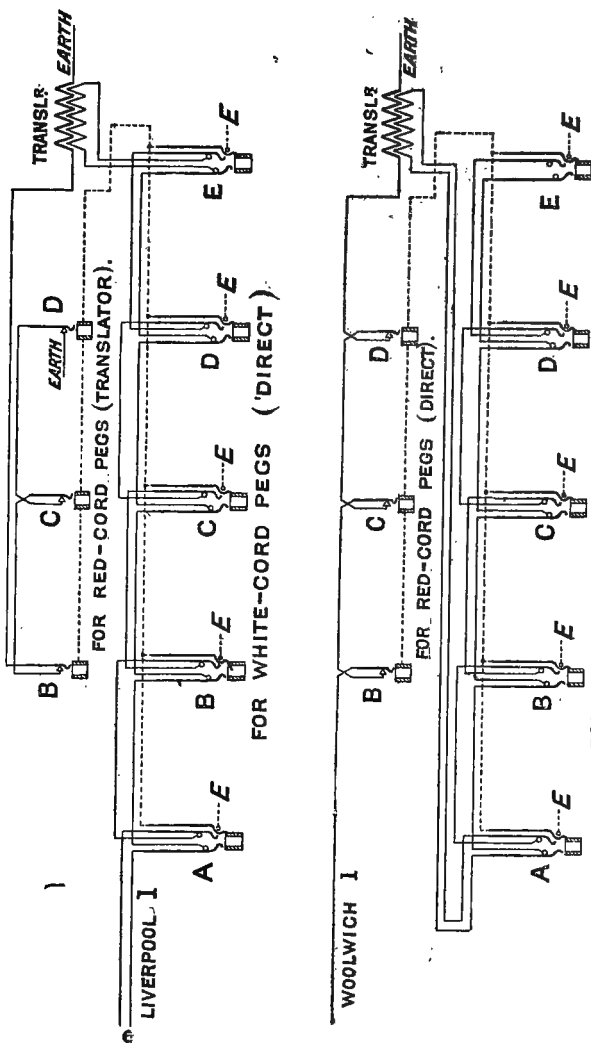

FOR WHITE-CORD PEGS (TRANSLATOR).

Figs. 260 and 261. Showing Method by which, on a Mixed Single-wire and Metallic-circuit System, Translators are or are not introduced on Trunk-lines, according to the Connection required.

metallic-circuit switch-hole of the required line. It will be seen, however, that the effect of connecting the double-wire "Coleman 8" in the lower spring of "Liverpool 1" is to put the two circuits in direct communication, whereas the insertion of the same peg into the corresponding hole of "Woolwich 1" secures the introduction of a translator between the single and double-wire circuits.

On the other hand, if a demand were received at section B for connection of "Kilburn 4" through to "Liverpool" or "Woolwich," the operator, on lifting the peg and finding its cord to be red, would insert it into one of the upper series of holes, so giving direct communication for a single wire or translation between "Kilburn 4" and the metallic circuit required.

This system must necessarily be of a transitional character, inasmuch as the need for metallic circuits to secure good communication is becoming increasingly recognised, and there are, consequently, very few single sub-trunk wires remaining; but the system is still applied to subscribers who have single-wire circuits direct to the Central Exchange.

It should be observed that sections A and E are not fitted with single-wire spring-blocks, the reason being that the incoming lines at those two sections are supposed to be all metallic, so that the operators have no "red cords" to deal with.

This system of working is very quick and simple, but it is found that six important trunk lines or twenty four junction wires are the maximum that can be attended to by one operator. A complete section of the multiple switch is allotted to three operators.

CHAPTER XXII.

TELEPHONE CALL-OFFICES.

IT is usual, in connection with most telephone exchange systems, to instal stations at various convenient points, where either subscribers or the general public can obtain communication with the various subscribers to the exchange. The usual practice in England is to make a fixed charge for three minutes' conversation to non-subscribers, while subscribers to the exchange are allowed to have the free use of the telephone at the call-station as an additional accommodation covered by the terms of their agreement—that is to say, free use for subscribers connected to the same exchange, and the usual terms for trunk-line communications.

The lines of call-offices at which there is an operator in charge are worked in practically the same way as ordinary subscribers' lines, except that the operator in charge gets the required connection, and then hands over the instrument to the customer.

The instrument must, of course, be fitted within a silence cabinet. These cabinets are of very various construction. That used by the Post Office has already been described (p. 227); it is almost absolutely sound-proof. The form of those ordinarily used by the

National Company is simply a large square wooden cupboard with a double glazed window in one side, or in the door. Some of the American companies adopt a very elaborate glass-panelled structure, the silence qualities of which we have not tested. The least rigid test should require that a person standing quite close to the cabinet should not be able to overhear the words of a customer inside, even if he should be speaking in a loud tone. This also secures the speaker against serious interruption by outside noises. It is desirable that the door be fitted with a spring arranged to keep it normally open, so that the cabinet may be ventilated when not in actual use.

Under the Post Office system the different post-offices themselves become the natural call-offices, and the counter-clerks are placed in charge. As these officers often have a considerable amount in cash, stamps, etc., under their care, there is a rigid rule that they are not to leave the counter. On the other hand, also, only officials of the department are admitted behind the counter. The practice, therefore, is to give the counter-clerk absolute control of the call-office circuit without the need of moving from his place. This is secured by means of a "counter-communication" switch and the other apparatus shown in fig. 262.

The silence cabinet is fitted with a telephone and a bell, while behind the counter is fixed a board on which are a telephone, a 1,000^{ohm} polarised indicator-relay and a bell, in addition to the counter-communication switch. In the NORMAL position of the switch, which is that shown in fig. 262, a permanent current passes to the exchange from the cabinet telephone battery; but as this is quite independent of the telephone switch-levers,

it is not possible, when the switch-handle is in this position, for an unauthorised person to gain the attention

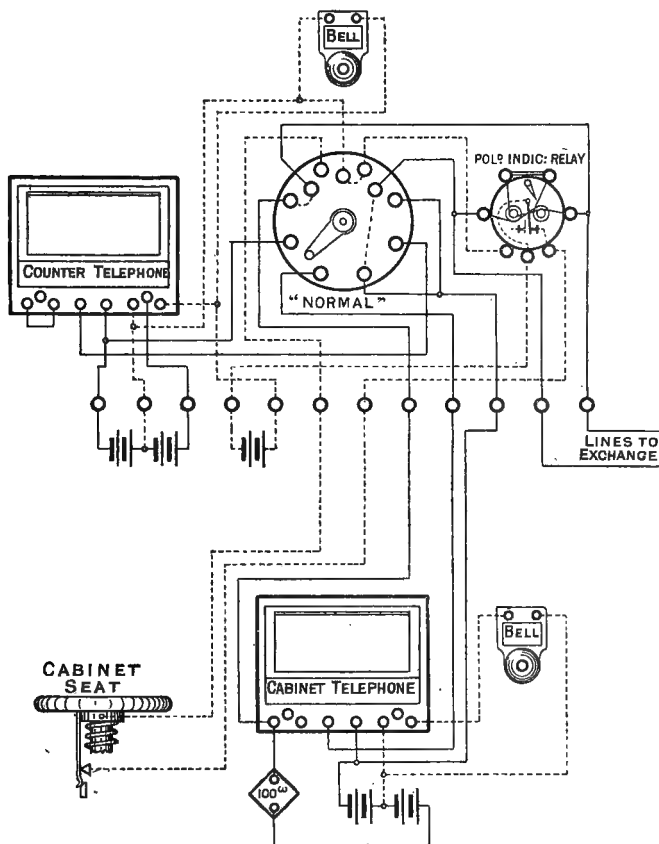

Fig. 262. Apparatus Connections at Post Office Telephone Call Stations. of the exchange operator. In permanent derived circuit on the line is the polarised indicator relay, by which the exchange operator can call the counter-clerk.

In order to answer a call or to gain the attention of the switch-operator, the counter-clerk must turn the switch-handle to "COUNTER." To gain attention the counter-clerk should then give a vibratory call by repeatedly depressing the telephone press-button, and speak when a reply is received on the bell. To answer a call, it is necessary only to listen and speak, after turning the switch-handle to "COUNTER."

When an application is made for communication through the exchange, the counter-clerk ascertains the number, etc., of the required subscriber, turns the switch to "COUNTER," and arranges with the switch-clerk for the connection. If the line required is engaged, the application is registered by the switch-clerk for its proper turn, and the applicant is requested to wait. Upon the switch-clerk informing the counter-clerk that the required connection can be made, the applicant is asked to enter the cabinet, and the counter-clerk turns the switch to "THROUGH." This movement completes

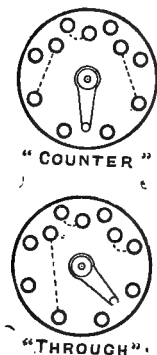

Fig. 263.

the local circuit of the polarised relay, and causes the counter bell to ring until the circuit is broken at the contact-spring on the cabinet-seat by the applicant sitting down in the cabinet.

The duration of conversation is checked by the exchange operator; but the vertical position of the needle of the indicator relay during the time that the telephone receivers are in use enables the counter-clerk to determine whether it is necessary at the termination of a conversation to request the applicant to wait until

he has ascertained by inquiry of the switch-clerk the length of time during which the trunk-wire was occupied. The rising of the spring-seat when the user leaves the cabinet causes the counter bell to ring, so warning the counter-clerk of the fact. The NORMAL position should be at once restored, unless a further communication is to be made with the exchange.

The switch-connections in the COUNTER and THROUGH positions are shown by fig. 263.

The call-office system adopted at the London Stock Exchange for the convenience of members who wish to communicate with their own offices probably stands unrivalled for smartness of switching. It is only practicable, however, with a comparatively small number of subscribers under exceptional conditions.

All the subscribers' lines are led to a switch in an adjacent exchange in the ordinary way, and in a room adjoining the Stock Exchange about fifteen silence cabinets are provided under the control of a special operator. Between the switch-room and the cabinets are lines which terminate at the switch in pegs and cords, so that any cabinet can be connected to any circuit on the switch. The operator has a speaking-wire to the switch-room, on which the switch-clerks listen continuously. The subscriber himself does the ringing, and as he is always calling his own *employés* he generally gets very prompt attention. The whole operation thus resolves itself into this. As the subscriber enters the call-room, he gives his number, which the operator repeats aloud to his telephone, with the addition of a cabinet number. By this means the subscriber knows which cabinet he is to use, and the switch-clerk is simultaneously informed what connection is to be made ; so that,

as there is only a peg to be inserted in the switch-hole, the required connection is made by the switch-clerk by the time the subscriber gets into the cabinet. On coming out he simply says “(number) *off*,” which is repeated by the operator to the switch-clerk, who removes the peg. Suppose, for instance, subscriber No. 57 comes in: he says, “57”; the operator says, “57 *on* 8,” and by the time the subscriber has got to No. 8 cabinet, its connection with his line has been made. He rings his office and speaks; and on leaving the cabinet says, “57 *off*,” which, on being repeated to the exchange by the operator, secures the immediate clearing of the line. The operator in the cabinet room has a set of “dummy” indicators by which he registers the engaged cabinets.

If a member is called by his office, the operator is informed by the exchange clerk, and calls the number of the member required to a porter seated outside, through whom a Stock Exchange “Waiter” is informed, whose duty it is to shout the number in the Exchange itself—the usual method of calling a member.

AUTOMATIC CALL-BOXES.

In cases where, while it appears desirable to provide a public call-office, it is inconvenient or too expensive to place an operator in charge, “automatic call-boxes” are employed. By means of these, the public can obtain communication through the exchange on paying for each conversation, and, by some devices, where it is so desired, subscribers to the exchange can obtain free use of the call-office.

The number of different forms of automatic call-box is very considerable

The method of working with the most simple forms of call-box is as follows:—When anyone wishes to communicate he calls from the telephone in the ordinary way, and tells the exchange operator the number of the subscriber wanted. If that subscriber is free to speak, the operator requests the caller, if he is *not* a subscriber, to pay the fee—3d. if the call is to the same town, or 6d. if to another town in the district. As the money is put into the box the operator has to check it before making the connection. Anyone who *is* a subscriber is asked to give the signal by means of a special key, supplied to each subscriber for the purpose. In places where subscribers are not allowed free use the boxes are made without any slot for inserting a key.

The box is made with two slots in the top—one for pennies, the other for sixpenny pieces. There are corresponding openings in front for subscribers' keys—one for local, the other for trunk-line connections.

Smith and Sinclair's call-box gives the operator power to do as above described in the following way:—At the exchange is fitted a relay with local battery and bell. One side of the relay is put direct to earth, the other is in circuit with a battery of a few cells and a special connecting peg. Before a through-connection is given, the special peg is inserted in the call-office switch-hole, the indicator is cut off, and a battery current flows to line. The relay local circuit is thus closed, and the hammer of the bell rests on the dome. Now, each time the line-wire is disconnected the bell will give one beat, and it is arranged at the automatic box that each penny as it drops down a shoot into the box shall momentarily disconnect the line through two springs (fig. 264). If a smaller coin were put in, it might disconnect one of

the two springs ; but, in order that the signal may be sent, it is necessary that both springs be acted upon at the same moment, which is impossible with a coin that is too small. A local subscriber's key inserted and turned disconnects the line, thus giving the same signal.

If the connection wanted requires that a sixpence be put in, the operator does not use the special peg, but listens on the telephone. In dropping into the box,

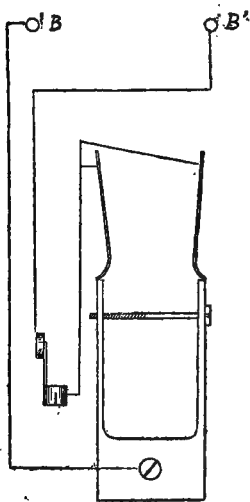

Fig. 264.

the sixpence disconnects the primary circuit of the telephone at the call-station, that circuit passing through the automatic box. Here, as in the other case, a smaller coin than a sixpence will not operate, and only a trunk-line subscriber's key will disconnect this circuit. When the local circuit is disconnected, a distinct, smart click is heard by the operator, who thus checks the payment before making the required connection.

One modification of the working is that without other special apparatus a battery is connected to line through the operator's telephone. After a little practice the operator can with perfect certainty distinguish between a noise produced in the telephone by the disconnection of the main line with a permanent current upon it, and that produced by the interruption of the microphone circuit. Disconnecting the line produces a noise like a heavy thud, instead of the sharp click which occurs in the other case.

Another modification is that the coin, in dropping into the box at the call-station, disconnects a local circuit having a bell in it, and the sound of the ring is conveyed by the telephone at the call-station to the operator at the exchange, who is listening. This only requires that the telephone be fitted near the call-box.

A similar and yet more simple device is *Cotterell's*, which has no special electrical contrivance whatever. The "call-box" is simply a money-box fitted with two shoots for the coins and a gong at the end of each, against which the coins must strike in falling. While the payment is being made the speaking circuit is kept open, and the operator listening at the exchange hears the ring and can easily distinguish from the tone which gong has been struck.

A more elaborate device has been invented by Messrs. Poole & McIver, which provides for the timing of the conversation, and the disconnection of the call-office telephone at the end of three minutes. This is fully described in "The Practical Telephone Handbook."

Fig. 265 is a view of the mechanism of a call-box introduced by Messrs. *Mix & Genest*, which presents some features of interest. The coin, on being put into the slot, *S*, passes through the trough *P* into a vertical slide. The trough *P* is so arranged that if a smaller coin than the authorised payment be put in, it will be directed into an open refunding box. If, being correct, the coin passes into the vertical slide, it depresses a light lever *R*, and then comes to rest on the disc *r*, which is the upper of three discs which are geared together, and whose peripheries protrude into the right-hand groove in the slide. These discs are actuated by the armature of the electro-magnet *N* through the link *m*.

When the coin is in the position shown, and the light switch-lever is depressed, the telephone instrument becomes connected to line, the exchange can be called in the usual way, and the caller's want explained. If the required line is engaged so that the applicant's requirement cannot be met, he is informed to that effect, and can recover the coin from the machine by pressing back F by means of a button not shown in the figure. The effect of this is to throw forward the upper section of the vertical groove clear of the discs, and so permit the coin to fall into the refunding box. If, however, the connection can be made, a current sent from the exchange operates the armature of N by means of the relay D, and releases the coin by slightly turning the segments. It thus falls into the lower section of the slide, from which it cannot be refunded. The periphery of r_1 now projects to the left and detains the coin; but when the current ceases and the armature is released the coin falls to r_2 , where it remains throughout the conversation, being released and allowed to fall into the cash-box by the ring-off signal. In its fall from r_2 the coin depresses the light lever R_1 , which raises R, and disconnects the telephone from line. Lever R_1 is also actuated when the coin is made to fall from R into the refunding box.

If the ring-off signal should not be given by the caller, the next coin inserted into the slot, S, presses aside a small roller u attached to a lever, which, by operating the discs, mechanically releases the coin left in, and allows it to fall into the cash-box.

Messrs. Blakey, Emmott, & Co. have introduced a somewhat more simple instrument on the same lines.

From time to time the *toll* system of payment for the

use of a telephone line is advocated. This means payment by a telephone subscriber, wholly or in part, in proportion to the use that is made of his circuit. These

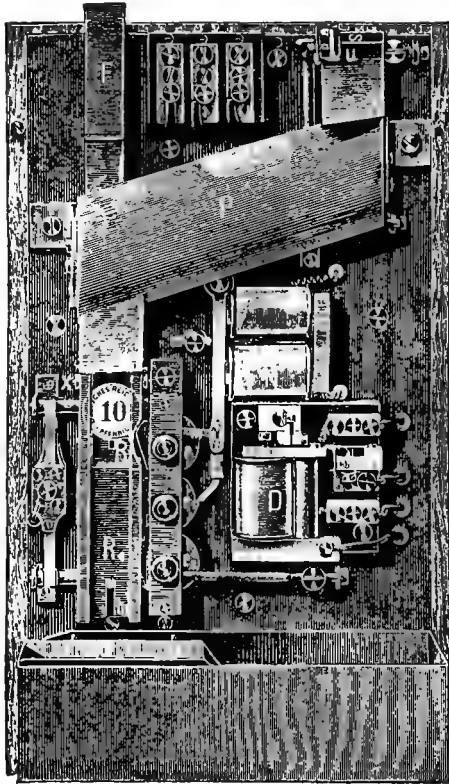

Fig. 265.

instruments would facilitate the introduction of some such system; but there are serious objections to its application.

CHAPTER XXIII.

MULTIPLEX TELEPHONY.

THE solution of the problems of duplex or multiplex telephony differs essentially from that of corresponding telegraphic problems, inasmuch as it is not possible to arrange for two essentially different series of currents, as is done in quadruplex working; nor to balance an artificial against the real line, as in duplex; nor yet to apply the principle of sub-division, as in the multiplex system. Yet the necessity of using two wires for an efficient telephone circuit while a single telegraph wire of any length is made to carry messages simultaneously in both directions as a matter of course, directed early attention to the question of multiplex telephonic working; and many methods of securing the desired result have been suggested, the general principle being to use the metallic loop for one circuit, and arrange for the two wires to be used as one for a second (single-wire) circuit.

An early American plan is shown in fig. 266, in which P, P, P', P' are the primaries, and S, S' the secondaries of four translators, two at each end of the metallic circuit. The corresponding coils on the two wires at each station are wound differentially, so that out-going

currents from T_1 or T'_1 , dividing between the two primaries, produce equal and opposite currents in the secondaries, and leave the telephones T_2 and T'_2 unaffected. Equally, currents originating in T_2 or T'_2 , which are in circuit with the secondaries, induce currents in the primaries which circulate in the metallic loop, but leave the earthed telephones T_1 and T'_1 unaffected. Theoretically the plan is right, and experimentally it answers well; but, in practice, the resistance and magnetic inertia of so many electro-magnetic translators kills the speaking in the metallic circuit. The reduced efficiency is still further emphasised when, for switching

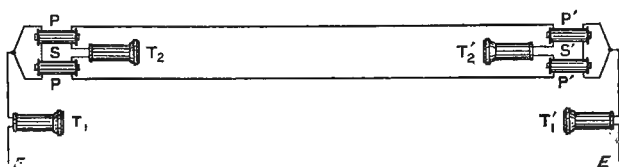

Fig. 266. Magneto Coil System.

purposes in an exchange, other translators have to be substituted for the telephones.

A plan which has given very good results in practice was devised in 1882 by Mr. Frank Jacob,¹ technical adviser of Messrs. Siemens Bros. The principle is that of the Wheatstone Bridge; fig. 267 is a diagram of the system. The two resistance coils R, R at each end must exactly balance each other, but it is not necessary that all four should do so. The wires forming the metallic loop should also balance in conductivity, insulation, and capacity; they must, of course, also be "twisted" or "crossed" (chap. xxviii.) to prevent inductive disturb-

¹ British Patent Specification 231 (January 1882).

ance. When these conditions are attained, communication may take place between the two pairs of telephones without the faintest sound of overhearing being apparent. Currents originating at T_1 split between R and R , pass T_2 on each side without affecting it (the two terminals of the receiver being at equi-potential), traverse both wires of the loop, and combine again after passing $R' R'$, going through T'_1 to earth. Currents starting from T_2 have three paths open to them: (1) through R , R and back; (2) through one wire of the loop which includes the telephone T'_2 , and back by the other wire; and (3) through one wire of the loop, R' and R' , and back by the other wire. The second of these is arranged to have by far the least resistance;

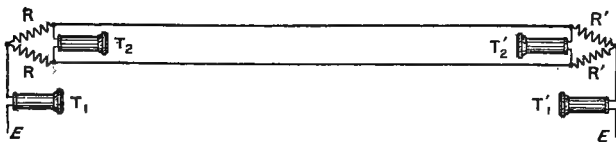

Fig. 267. Jacob's System for two Circuits.

and, if the metallic loop be of copper, the speaking is quite as good as on an ordinary metallic circuit. As regards T_1 and T'_1 , the insertion of mere resistance in a single-wire telephone circuit does not perceptibly interfere with the speaking, so that communication on the earthed section of the system is also good. T_1 and T_2 may be in different quarters of one town, while T'_1 and T'_2 may be in different parts of another.

Instead of being placed at the ends of the metallic loop, as shown, the earthed circuit may be taken off at any intermediate points. For instance, on a metallic loop between London and Brighton, an earthed circuit might be worked between, say, Croydon and Red Hill. The

earthed circuit, however, is practically a single wire, and, like all single wires, is disturbed by earth currents and by induction from neighbouring parallel lines. The metallic circuit is, of course, not so affected.

Fig. 268 shows an extension of this system by which four wires may be made to yield four working circuits, three of which are on metallic loops. If the route is subject to telegraphic induction, the earthed circuit may be omitted, and the three metallic circuits, $T_2 T'_2$, $T_3 T'_3$, and $T_4 T'_4$ retained.

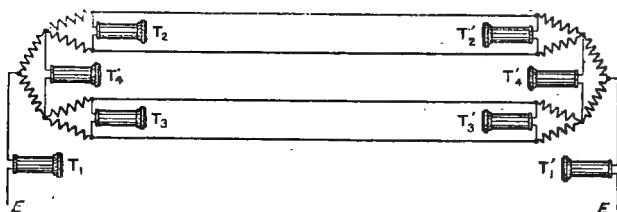

Fig. 268. Jacob's System for four Circuits.

A somewhat similar device was made also by Dr. Rosebrugh,² but his application seems to have had reference rather to derived telephone circuits upon telegraph lines—the subject of the next chapter.

² British Patent Specification 1,477 (April, 1879).

CHAPTER XXIV.

SIMULTANEOUS TELEGRAPHY AND TELEPHONY.

ALTHOUGH it has been generally recognised that metallic circuits are very decidedly best for telephone working, the expense of the double wires has made it very desirable that efforts should be made to obviate the need for their employment. The "speaking induction" between properly-insulated telephone circuits (the term practically includes leakage disturbance) is not generally very considerable; but where several wires used for telegraph purposes run for any considerable distance upon the same poles (or even along the same route on other poles), the currents induced by the telegraph signals render telephonic communication on single wires almost, and in some cases quite, impossible.

As the induction currents arise only while the primary currents vary, the *sudden* rise or fall of potential in the inducing wire produces a considerable momentary current, which results in a loud click in the telephone receivers. But if the same rise of potential in the primary circuit takes place *gradually*, the induced current is of longer duration and is correspondingly weaker.

Now, ordinary telegraphic signals are dependent upon currents which are characterised by a sudden rise and fall; so that they are calculated to produce the maximum of disturbance upon neighbouring telephone circuits. At the commencement of 1882, however, the

late J. F. van Rysselberghe, Consulting Electrician to the Belgian Administration of Telegraphs, conceived the idea of retarding the rise and fall of the current between zero and its maximum strength on the working of the Morse key, by the insertion of electro-magnetic inertia in the telegraph circuit.

In the first instance, Van Rysselberghe inserted an electro-magnetic coil having great self-induction between the front contact of the Morse key and the pole of the battery.

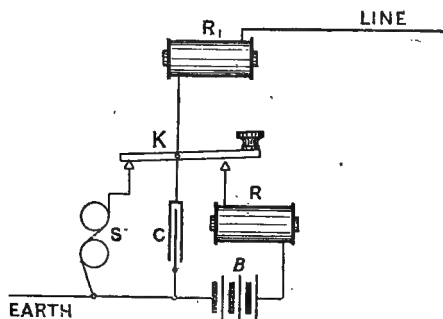

Fig. 269. Van Rysselberghe's Anti-induction System.

a neighbouring circuit by working the key was hereby considerably weakened. The insertion of a second electro-magnet between the key and the line, and a condenser between the line terminal of the key and earth, still further diminished the induced current.

This arrangement is shown in diagram in fig. 269, in which K represents a single-current key, S the telegraphic receiving instrument, R, R₁ the retarding coils, C the condenser, and B the battery.

On the depression of the key a considerable portion of the initial part of the current goes to charge the

condenser, and not until the condenser is fully charged can the potential of the line reach its maximum. The time of charge is appreciably increased by the electromagnetic inertia of R , and the rise of potential of the line is further retarded by R_1 . By this means the rise is so gradual that the currents induced in neighbouring wires are not sufficient to affect the telephone. The release of the key, by disconnecting the battery, permits a portion of the discharge current from the condenser to flow to line, thus tending to prolong the signal, so that the potential of the line is gradually reduced. Of course, the actual times of charge or discharge of the condenser, and the rise and fall of the potential of the line between zero and its maximum, are actually very small indeed, but relatively to the speed of sound vibrations in the telephone they are considerable. Thus, although the gradually rising and gradually falling battery currents do induce currents in the neighbouring wires which may cause the diaphragm of a telephone to vibrate, yet the sounds resulting from these vibrations are too low in pitch to be of a seriously disturbing character.

The resistance of the magnetic coils is usually 500 Ω , and the capacity of the condenser 2 micro-farads.

During the course of the experiments the question arose as to whether it might not be possible, by a convenient arrangement of the above apparatus, to work the telegraph and the telephone on one line, and Van Rysselberghe clearly showed it to be so.

The arrangements necessary for such working are shown in fig. 270. The telephone stations may be situated in different localities from the telegraph offices. The interpolated condensers C have a capacity of $\frac{1}{2}$ microfarad.

If, in addition to the line which is to be worked on the combined system, other telegraph lines are erected upon the same poles, every telegraph office upon each of these lines must be provided with a similar set of retarding apparatus, even if only the one line is to be used for simultaneous telephony and telegraphy.

If a second telegraph line be fitted up in the same way for both services, telephonic communication is still not disturbed by the telegraph service, but a telephonic conversation carried on in one of the two lines may be

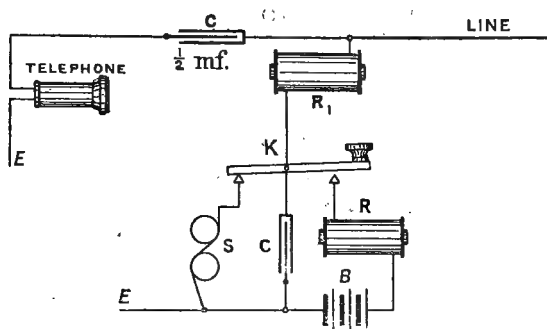

Fig. 270. Theoretical Connections for Van Rysselberghe's System of Telegraph and Telephone on same circuit.

overheard on the other line. The remedy for this is, where possible, to take *two* telegraph circuits on which to superpose each telephone circuit, so that the induction currents passing in the double wires may neutralise each other in the two condensers. The connection of one telephone station with another by a circuit formed of two telegraph lines can be made as indicated in fig. 271. Each of the two lines is connected with one side of the double condenser C C, and the telephone is joined between the other terminals of the condenser. The

satisfactory working of the arrangement, of course, depends upon all neighbouring circuits, as well as each of the two circuits used, being fitted with a complete set of induction apparatus.

This system is in somewhat extended use by the Belgian Administration, and under some conditions the possibility of dispensing with a separate telephone line is, no doubt, a material advantage. In England, however, it is certain that this advantage would have to be very dearly bought. The telegraph service is of vast and increasing importance, and some of the systems—especially the automatic fast speed—would be rendered

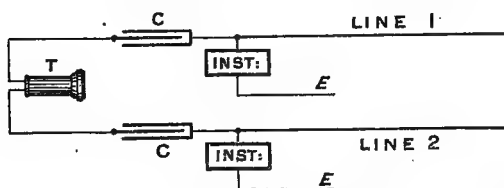

Fig. 271. Two Telegraph Lines used for a Telephone "Metallic" Circuit.

almost absolutely useless by the introduction of retarding electro-magnets into the circuits. Besides, the fact that the two services are controlled by independent authorities complicates any such application: but, even if it were not so, both the telephone and the telegraph are too important to permit of either being used in a manner detrimental to the other.

Another system, which is based upon precisely the same principle as that shown by fig. 267 in the previous chapter, was patented in France in 1891 by M. Pierre Picard. This device is shown diagrammatically in fig. 272. After what has already been said in

connection with multiplex telephony (p. 353) the scheme of working will be self-evident. Various special applications have been worked out—such, for instance, as the use of two separate telegraph circuits for one telephone circuit; and the reverse problem—namely, the use of one telegraph for two independent telephone circuits. In either of these cases two four-wire transformers are used at the intermediate point.

Since voltaic currents for signalling may not—and, indeed, cannot—be used on the secondary telephone circuits, special methods of calling have been necessary in connection with simultaneous telephony and tele-

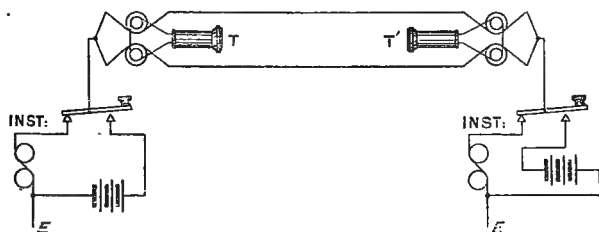

Fig. 272. Theory of Picard's System.

graphy. One plan, adopted by M. Picard, is shown by fig. 273. The coils of the indicator are differentially wound, so that, when joined up in the manner shown, the current from the battery *B* in one section neutralises the effect of the current upon the cores in the other section. It will be seen that the two sections are parts of two derived circuits upon the same battery, one being merely through one section of the coil-wire, while the other includes also the pivoted pendulum-lever *L* and the diaphragm *D*. The pressure of the screw at the lower end of *L* upon the centre of *D* is regulated by means of the weighted screw on the upper arm of *L*.

Now the diaphragm is placed in front of an electro-magnet inserted in the secondary (telephone) circuit ; and consequently, when alternating currents are transmitted to line, they are converted by the transformers, and, acting on the coils of *M*, cause the diaphragm to vibrate. This intermittently interrupts the circuit of *B* through the lever *L* and one section of the indicator coils, leaving the current in the other section free to actuate the indicator. In this way the signals are transmitted without difficulty.

Many other efforts have been made in America, as well as in England, to utilise the existing telegraph wires

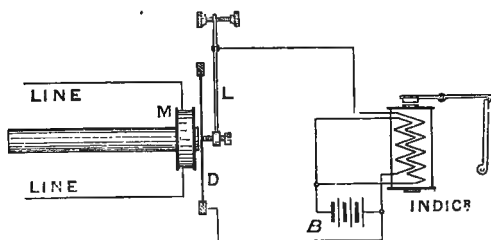

Fig. 273. Induction Call for Van Rysselberghe's or Picard's Systems.

for purposes of telephonic communication, the fact of its being possible to superpose minute undulatory currents such as are employed for telephone-working having been demonstrated by Mr. C. F. Varley in the year 1870. Elisha Gray, Edison, and others have employed systems other than speaking telephones on existing wires with some success ; while, in England, Major Cardew, of the Royal Engineers, made an exhaustive series of very successful experiments on this subject (p. 368).

In conjunction with the French Administration, an extended series of trials of the working of the various

superimposing systems was recently made upon one of the London-Paris telephone circuits. The systems tried were those of Cailho, Jacob, Picard, and Van Rysselberghe.

Monsieur Cailho in his system adopts the plan of placing the telephone circuit in derivation upon the two lines (as in the Jacob system, except that a telegraph instrument is used on the earthed circuit), or in a transformer circuit as shown in fig. 266. In either case the electro-magnetic coils bridged across the telephone have a resistance of only 10^6 for each section.

The Jacob system (with non-magnetic resistances and no condensers) was very feeble, so that this was modified (in accordance with Post Office experiments made some years ago) by the use of the electro-magnetic coils of 200^6 each arm. It will thus be seen that the differences between the Cailho, Jacob (as modified), and Picard systems are not considerable. This fact was also demonstrated by the experiments, inasmuch as alterations made in the conditions of the experiments about equally affected each system.

The conclusions derivable from the experiments indicate that the application of automatic telegraphy upon a telephone circuit, would not be practicable at a serviceable speed, and that Hughes' instruments would work satisfactorily only so long as the lines remained perfect. Slight faults, even such as are not sufficient to disturb ordinary telephonic working, at once lead to disturbance; and similar faults on adjoining telephone circuits result in those circuits also being interfered with by the superposed telegraph.

These facts, together with past experience, appear—at least under existing conditions—to preclude the hope of the introduction of any such system in England.

CHAPTER XXV.

MILITARY TELEPHONY.

ALTHOUGH at first it would appear likely that the telephone would find a sphere of extensive usefulness in military operations, when the conditions under which it is likely to be required in the field are carefully considered, several serious objections to its employment for transmitting articulate speech at once suggest themselves.

It is, of course, highly advantageous to an army to have the power of transmitting intelligence rapidly between its various divisions, outposts, wings, advanced and rear guards, etc.; but the intelligence so transmitted must be absolutely reliable, for the consequences of a mistake in the purport of a message may be so disastrous as to outweigh any possible advantage due to rapid transmission. Numerous instances are on record of fatal blunders which were directly traceable to a mistaken comprehension of verbal orders; so that it has been made an invariable rule in the British army that all important orders must be delivered in writing.

Now an order transmitted by telephone is worse than a verbal order delivered from one officer to another,

since it is probably transmitted verbally between two men who may have no comprehension of its meaning or scope, and by means of a mechanism which must be admitted to be far less efficient than direct verbal communication.

In assessing the probable frequency of mistakes in transmission in the field, the adverse environment of the operators at the two ends of the line must be considered. It is difficult to determine whether the banging of cannon and rattle of musketry would be more distressing at the sending or at the receiving end of a circuit. No doubt they would be reproduced by the transmitters with only too much fidelity. When to this is added the effect of the presence of numerous and probably highly excited staff officers, each demanding urgency for his particular message, the mental state of the unfortunate operator may be faintly imagined. The conditions are certainly not favourable to accuracy.

Another objection is the publicity inseparable from the act of transmission. A general may require the immediate transmission of some very important intelligence, but would not, as a rule, care to have it slowly and distinctly shouted by the stentorian lungs of an ordinary soldier; while at the outposts in proximity to the enemy such procedure would be clearly inadmissible. Still, although telephony proper cannot be considered altogether suitable for the transmission of military messages, it certainly has its own sphere of utility.

In standing camps, and even in temporary ones not in the immediate presence of the enemy, there is vast scope for its employment in carrying out the routine business of the camp, promulgating orders, requisitions, etc. The amount of correspondence of this sort in a

large camp is very considerable ; entailing, where the use of the telephone is not resorted to, the constant employment of a large number of orderlies, and the loss of much time between asking the simplest question—*e.g.*, the number of rations required by a certain regiment—and the receipt of the answer. All this kind of business is admirably performed by the telephone.

The experience hitherto gained in reference to the forms of instruments to be used in the field has led to the adoption of Berthon transmitters (p. 85) in combination with Ader receivers (p. 45) and a magneto call-bell system.

For "exchange" working flexible cords are found inconvenient, and some form of the Swiss commutator (p. 179) is accordingly adopted.

Telephone exchanges are now established in almost all fortresses, thus providing communication between head-quarters and the various forts, departmental offices, etc. All messages are written on telegraph forms and treated as far as possible simply as telegrams.

Telephones have also proved of great service in connection with rifle-practice. Suitable cables are buried along the various ranges, and there are special arrangements at the different firing-points to facilitate rapid joining-up of the apparatus. For this particular purpose the instruments are fitted in Sedan chairs, so that they can be easily moved from place to place and be protected from rain, etc.

The principal use of the telephone in military operations is, however, as a telegraphic receiver. Ordinary telephonic receiving instruments require a comparatively considerable current to work them reliably, and for the most part they also need more or less delicate adjustment. With the telephone this is not so ; and, conse-

quently, almost as soon as the telephone came into practical use, its possible value as a military telegraph instrument was appreciated; and it is in this direction rather than in its use for articulate speech that it has made progress for military operations. Its extreme sensitiveness renders it invaluable for conditions under which small battery power and inferior line insulation are often the necessary working conditions.

In the first instance it was proposed to use the telephone to receive currents sent by a Morse key in the usual way, but this was soon proved to be impracticable. The sounds produced by the make and break of the circuit were so similar that there was a tendency on the part of the clerks to read the signals reversed; also when any Morse circuits were being worked in the vicinity the induced signals caused interference.

To eliminate these defects a system of sending intermittent currents was introduced. The intermittent currents produce a musical note in the telephone as a signal, which, of course, cannot be read reversed, nor is it appreciably affected by any ordinary induced current. Further, greatly increased sensitiveness is attained with less expenditure of battery-power.

This system was practically tried by Major Cardew, R.E., in 1881, when the arrangement adopted was only very slightly different from that used at the present time.

The connections of the system are shown by fig. 274. The "vibrator" *v* consists of an electro-magnet with an armature mounted upon a spring and a back contact-stop; the coils, armature, and contact forming, with the key *K*, a local circuit for the battery *B*, which consists of only a few cells. On the depression of *K* the battery

circuit is completed, so that the armature is attracted, thereby breaking the battery circuit, whereupon the armature falls back and re-establishes it; and so on, exactly as an ordinary trembler bell, except that the vibrations are sufficiently rapid to produce a musical note. It will be seen that the line is connected through the coils of *V* and the telephone receiver *R* to earth.

The electro-magnet, then, with its vibrating armature, is employed at the sending end of the line to transform the ordinary battery current into a pulsating current

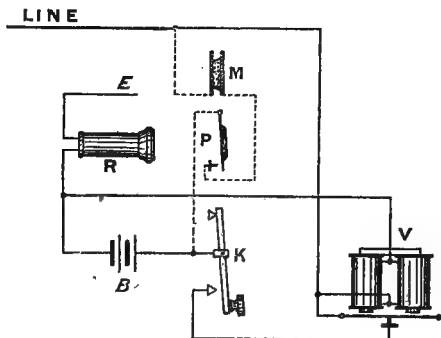

Fig. 274. Cardew's Vibratory System.

capable of producing a musical note in the telephone; the signalling is effected with the ordinary Morse code.

The telephone on which the signals are received is inserted in the line and not on the back contact of the key, which is the more usual plan. The reason for this is that the telephone at the sending end of the circuit performs the office of the usual galvanometer, and shows the clerk that the signals are going out to line.

It may be observed that the current through the vibrating transmitter is practically unaffected by the

state of the line, even if broken or very leaky, since the resistance of the magnet is only 10 ohms. This is of great utility, as signalling has frequently to be carried on through a broken wire, the ends of which make more or less earth, and also, in some cases, through wires lying upon the ground. In fact, it may be said that it is not so much the direct intermittent currents as the "extra currents" induced in V by the charge and discharge of the coils, that secure the effective signals on this system.

The connections are arranged so as to enable a Berton transmitter, M , to be used for speaking when required, the magnet coil acting as an induction coil. No switch is necessary with the exception of a contact-making switch for the microphone circuit, which is closed by the action of the hand grasping the handle of the instrument. Verbal communication is only permitted between officers; all messages transmitted by clerks are sent in Morse characters and transcribed in the usual way.

The advantages of the system for field work may be thus summed up:—

1. Its extreme sensitiveness, enabling communication to be effected through faulty lines, uninsulated wires laid on the ground, very bad joints, earths, etc. This is of great importance in connection with hastily constructed lines; and messages have frequently been got through lines which were altogether unworkable with ordinary instruments.

2. The great saving of battery power effected by its use: 10 cells are the maximum that are ever used with it, and it works with even one cell; also the current, being intermittent, has little effect in polarising the battery. Of

course, when the microphone is used, there is a greater expenditure of battery-power, but this is not an essential part of the system.

3. The fact that the telephone as a receiving instrument never requires adjustment frequently saves much time in rapidly running out a line and getting into communication.

4. Speech may be resorted to when desired without change of connections or complication of instruments.

5. The "buzzing" signals are much more easily picked up by operators trained to read flag and lamp signals than are the Morse signals.

Although very useful in field telegraphy, this vibrating system is not suitable for general work on the permanent telegraphs of the country for the following reasons :—

1. The note, or "buzz," is more fatiguing to the reader than the ordinary Morse sound signals, at any rate, to clerks used to the latter.

2. It is taken up by induction on parallel wires, causing injurious interference.

3. It is much enfeebled by all kinds of induction—electro-magnetic induction from parallel wires; electro-magnetic inertia from the electro magnets; and electro-static induction on long lines, especially when under ground or submarine.

It has, however, done good service on the postal telegraphs in getting through on faulty wires after a heavy snow-storm.

The vibrator system above described is in some cases superimposed upon a Morse circuit by aid of so-called "separators." Disturbance of the vibration signals by the direct currents of the Morse system is prevented by the adoption of a device similar to that used by

Van Rysselberghe (p. 357) ; that is, by means of electro-magnets and small condensers.

On the depression of the key of the Morse circuit, the $\frac{1}{8}$ mf. condenser forms a short-circuit for an instant, and thus lowers the potential of the battery. At the same instant an electro-magnet by its self-induction retards the passage of the current to line.

Both these effects last for a very minute fraction of a second, but are sufficient to soften off the click in the telephone (which would otherwise be very loud) so that it is not perceptible when receiving vibrator signals, and only slightly audible even when no other signals are being received by the telephone.

Should the instruments be used on lines having one or more intermediate stations, the connections are slightly different at each station, as shown in fig. 275.

The whole Morse apparatus at the intermediate station is now, as it were, shunted by the $\frac{1}{8}$ mf. condenser. This is necessary, as otherwise the vibrator signals received from one side would have to pass through the coils of the Morse instrument when the key was not depressed, which would diminish their force ; while, when the Morse key was depressed, they would pass by the battery, which would not diminish their force. The signalling on the Morse would therefore interfere with the receiving on the telephone ; but by putting the condenser across the Morse circuit this is quite prevented, the vibrator signals now passing through this condenser, which opposes no resistance to them.

If it be desired to establish a temporary intermediate station on a line worked either with separators or with vibrators alone, it can be done, without interfering at all with the normal working, by attaching a vibrator

through a $\frac{1}{10}$ mf. (or smaller) condenser. This is shown at station D in the diagram (fig. 275).

It would, of course, not be necessary to use a separator for this purpose if the small condenser alone were procurable.

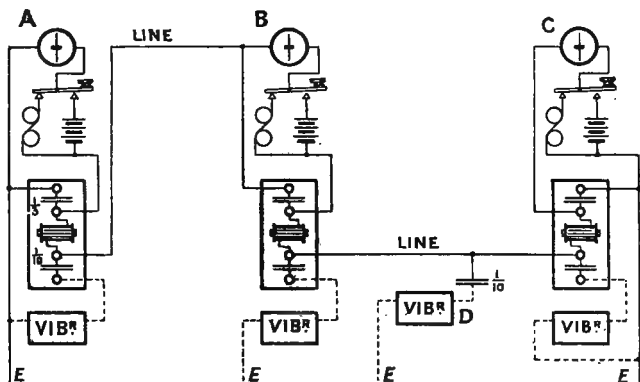

Fig. 275. Vibrator System superposed on a Morse Circuit.

This superimposing system will undoubtedly often be of considerable value in field service, where key-speed working is invariably adopted, and where, consequently, the retardation of the ordinary Morse signals is of no moment.

CHAPTER XXVI.

DOMESTIC SWITCHBOARDS.

IN warehouses, factories, and other large establishments where easy communication between various offices and departments situated in the same or adjoining buildings is of great value, or in large private residences, the telephone may be employed with great advantage.

A great number of neat and ingenious devices have been made in this connection, the essential requirement for which is simplicity in manipulation; and domestic switchboards to meet almost any conditions both as to working and as to expense and finish are now obtainable. It will be possible here to describe only a limited number of the most characteristic forms.

The Consolidated.—Apart from the fact that the Consolidated Telephone Company was one of the first to recognise the need for switches of this class, the switchboard ¹ (fig. 276) produced by them is worthy of a high place for its simplicity and compactness.

To the left of the figure is shown the telephone transmitter, of granular form: it is fitted upon light brackets, and beneath it is a call-bell of the form

¹ British Patent Specification 5,867 (December, 1889).

shown in fig. 92. Just below the bell is the calling press-button. On the right is the telephone receiver, hanging upon the hook of an automatic switch. In the centre is the handle of the line-switch, of very convenient capstan form, fitted with a pointer. Each

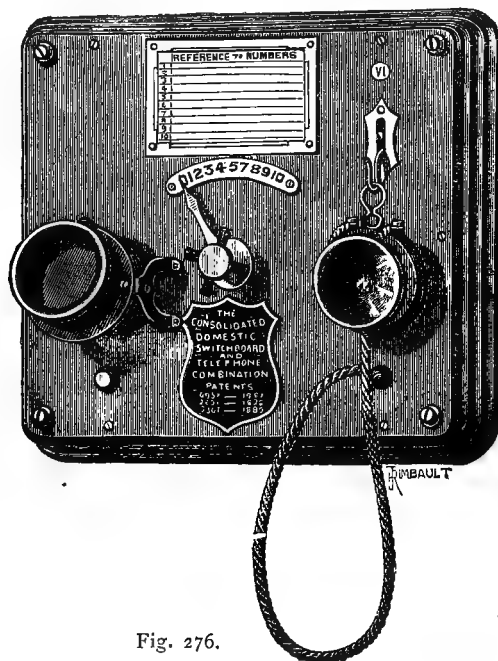

Fig. 276.

office or room on the system is provided with one of these instruments; and a specially-made cable (containing one wire more than the number of instruments to be fixed) makes the circuit of the whole system. The wires, being different coloured, are easily identified.

Fig. 277 shows in diagram form the back of the instrument, from which the whole principle of working will be

clear. Each line in the system is brought to a spring O, 1, 2, 3, the station line itself, whatever its number, being invariably brought to "o." The station number is consequently omitted from the position-plate of its own instrument ; for instance, in fig. 276 "6" does

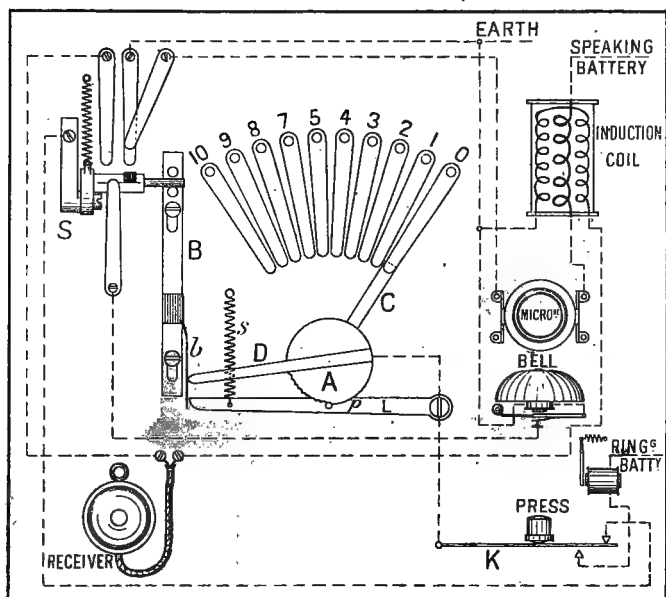

Fig. 277. About $\frac{1}{2}$ full size.

not appear on the position-plate, because the instrument illustrated is No. VI.

Fixed upon the handle-axle, immediately behind the pointer, is a cam C, by means of which the speaking and calling circuits of the instrument may be connected to any line. Upon the same axle is a spiral spring, so fixed as to tend always to hold the cam in

the zero position, as shown ; and above the spring is a circular plate A, with slight gaps in its periphery. A circular pin p , projecting from the lever L, tends to engage in these gaps through the tension of a spiral spring s . When p is free to engage with the teeth of A it acts as a detent, and holds the cam under any one of the springs beneath which it may be brought. The form of the teeth allows of the handle being easily turned in either direction within the limits of the proper range. In connection with the automatic switch S is a sliding bar B, and the spiral spring attached to the switch tends to raise both the bar and the switch-lever, which are normally depressed by the weight of the telephone receiver. Upon B is fixed a stiff, flat, insulated spring b , which is normally, as shown, just clear of the end of lever L, and actually rests against the end of arm D, which is fixed upon A.

Suppose, now, that a call is to be made to line 4. The pointer is turned to "4," bringing the cam under the spring so marked, a position in which it will be held by the detent. By the depression of K a current will be sent to line 4, and at both stations the receivers will be lifted and conversation will ensue. The removal of the receiver, however, besides effecting the usual alteration of connections, modifies the mechanical conditions. Immediately the cam is turned from the zero position the arm D moves away clear of the flat spring b , which consequently rests on the end of lever L. Now, when B is raised owing to the removal of the receiver, b is raised clear of the lever, and accordingly moves slightly forward. When, therefore, at the conclusion of the conversation, the receiver is replaced, the end of b descends upon the end of L, and, by depressing it, frees

A from the detent p , whereupon the spiral on the handle-axle restores the cam to the zero position. This involves also the return of the arm D, which accordingly presses the spring b again clear of the end of L, and leaves p free to engage with the teeth of the ratchet-disc A. Thus the normal position is automatically restored and the call of any station can be answered by the depression of K. It must be observed, however, that if the handle should be turned from zero, and so left after the receiver has been replaced, the call circuit of that particular instrument would be disconnected. This slight defect might be readily removed by the fitting of a contact beneath spring o, upon which that spring would rest when the cam was moved from zero, this contact being connected to a second lower spring at the automatic switch, so that, so long as the receiver was holding down the lever, the bell circuit would be complete, whatever the position of the cam. The prime object of the automatic replacement—the prevention of “replying” on a line that has not called—is, of course, not affected. It should be noted however, that the existing arrangement has the advantage of preventing systematic eavesdropping upon any particular circuit, which in other cases can generally be managed by putting the instrument to receive all calls on any one line.

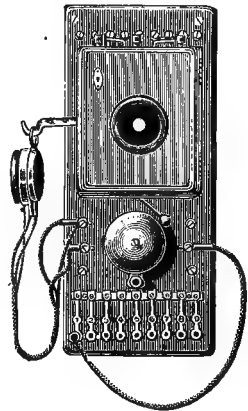

Fig. 278.

A desk form of this instrument is also made.

It is evident that conversation can be carried on simultaneously by any pairs of stations; for example,

1 and 5, 2 and 4, 3 and 9 could all be in communication without interference from each other.

The Western Electric.—The form of domestic switchboard produced by the Western Electric Company is shown in fig. 278. This is arranged to work by peg and cord, instead of by means of a handle with cam moving beneath springs. The stock size is for ten offices, and the boards are accordingly provided with nine

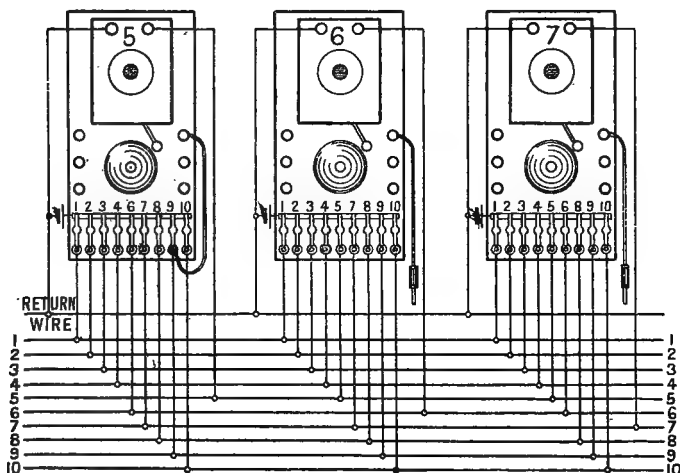

Fig. 279.

switch-holes or sockets, into any one of which the instrument-peg can be placed. Above the holes is a brass bar to which one pole of the ringing battery is connected, and fitted upon which are springs so placed that, if depressed, they make contact with the switch-sockets over which their ends project, but in such a manner that the peg can be inserted in a hole without touching the corresponding spring. Thus these springs

serve as calling press-buttons on each line. The insertion of the peg in a socket connects the instrument with the corresponding line. For instance, if No. 5 wants to speak to No. 9, spring 9 is depressed, and the peg is then placed in socket 9. No. 9 has to respond by *speaking*.

The switchboard comprises a transmitter complete with watch receiver and a bell. Fig. 279 shows the connections for three stations—5, 6, and 7.

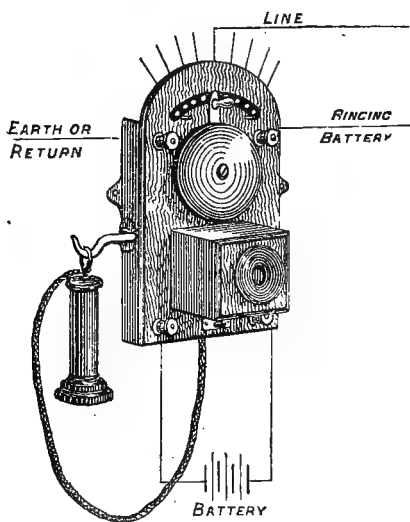

Fig. 280.

Anders-Elliott.—Fig. 280 shows an inexpensive combination of domestic switchboard, complete with microphonic transmitter and Bell receiver. The station-line is always connected to the centre contact-stud of the switch and the other lines to the studs on either side, according to their station numbers.

The apparatus is used in the following manner:—The

switch is turned to the stud of the line required, and held there until the call has been given and the telephone receiver removed from the hook. The rising of the automatic switch-lever causes the line-switch to be held in the required position, and the telephone is then connected to the line of the station that has been called. Replacing the receiver secures that the line-switch shall return to zero, and thus automatically restore the normal conditions. The mechanical action is obtained by means of the device shown in fig. 281. The disc *D* is fixed

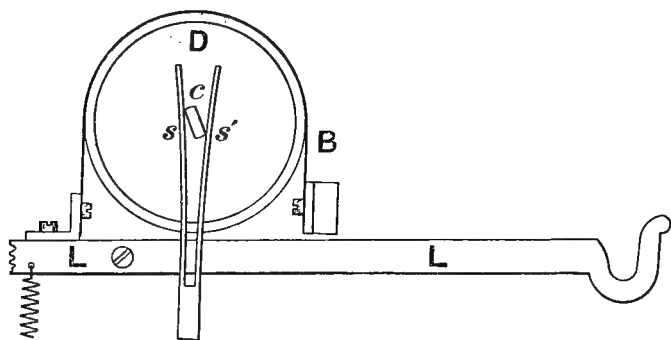

Fig. 281.

upon the position-switch axle, and turns with it; in its centre is fixed the double cam *c*, which, being acted upon by the two flat springs *s*, *s'*, tends to maintain a vertical position, and so hold the switch to zero. If, therefore, the switch be turned to either side as shown, *s*, *s'* will ordinarily restore it to its normal position as soon as the handle is released. When however, the automatic switch-lever is raised by the removal of the telephone receiver, a spring friction-brake *B*, which partly surrounds the disc, is brought into contact with its periphery, and by this means the

switch is held in any position to which it may be brought, against the influence of the springs s, s' . The replacement of the receiver upon the hook, by raising the inner end of the switch-lever L , removes the friction-brake, and the springs automatically restore the switch to zero. This instrument is the invention of Messrs. Anders, Elliot & Co.²

"*Line Selectors.*"—This is the designation of a domestic switch for several lines, which is made by the International Electric Company. Its general

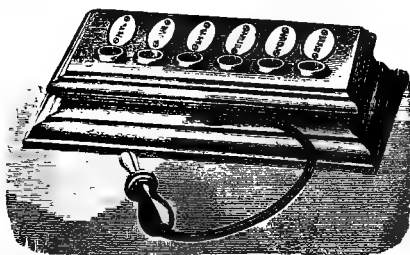

Fig. 282.

principle is similar to the peg-and-cord arrangement of the Western Electric Company, except that the ordinary press-button is employed in lieu of a special spring for each line. It is arranged also with the switch portion independent of the telephone, etc. (fig. 282), to facilitate the use of any form of telephone according to requirement, and also because it is claimed that in many cases particular points need only to communicate with a limited number of stations in a system, and not with all; in which circumstances the number of holes in the line selectors at such points

² British Patent Specification 3,404 (1891).

may be reduced accordingly. The difference in cost, however, would generally be very trifling, while the reduction in convenience would very probably be con-

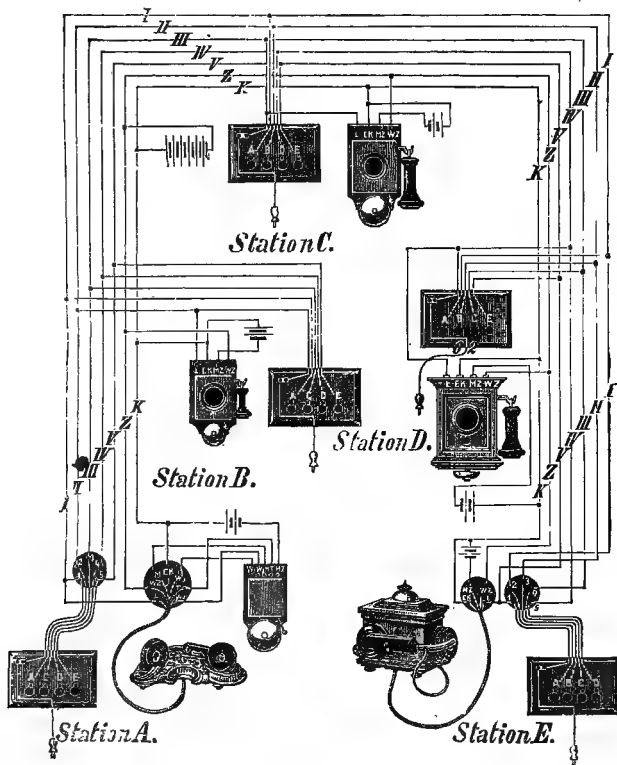

Fig 283.

siderable. Where it would be worth while to make the reduction would be in the case of stations (for instance, coachman's house or gardener's lodge) which were at a distance from the general group. In such cases the running of one (or two) wires, instead of the full number,

might make a considerable difference. It may be remarked that, in the same way on the systems already described all the points need not be fully connected.

As in all these systems, if *two* wires above the number of stations be used, a ringing battery common to all the stations may be employed. The connections of five stations, A—E, are shown by fig. 283, in which typical differences in the forms of telephones are indicated. At stations A and E are shown table telephones—the latter complete and the former requiring a separate bell the case of which also encloses the induction coil. For such circumstances wall (or table) rosettes are used (fig. 99), from the centre of which the flexible cord is brought to the telephone set.

*Sloper's "Secret" System.*³—The General Electric Company have introduced a very simple and ingenious device, by means of which, it is claimed, a conversation can be carried on between any two points in the system without the possibility of its being overheard by a listener at any other point. The general system for four stations, 3, 4, 5, 6, is shown diagrammatically in fig. 284.

As usually constructed, the press-button P is concentric with the revolving cam C, but in the diagram it is shown separate for clearness. For ordinary use the switch is worked substantially in the manner already described for other systems. The caller places his switch to the number of the required correspondent, and rings by depressing the button, whereupon the correspondent replies by speaking (his switch being to "reply," as shown at offices 4 and 6). Conversation can then take place over the called-office line and the return wire.

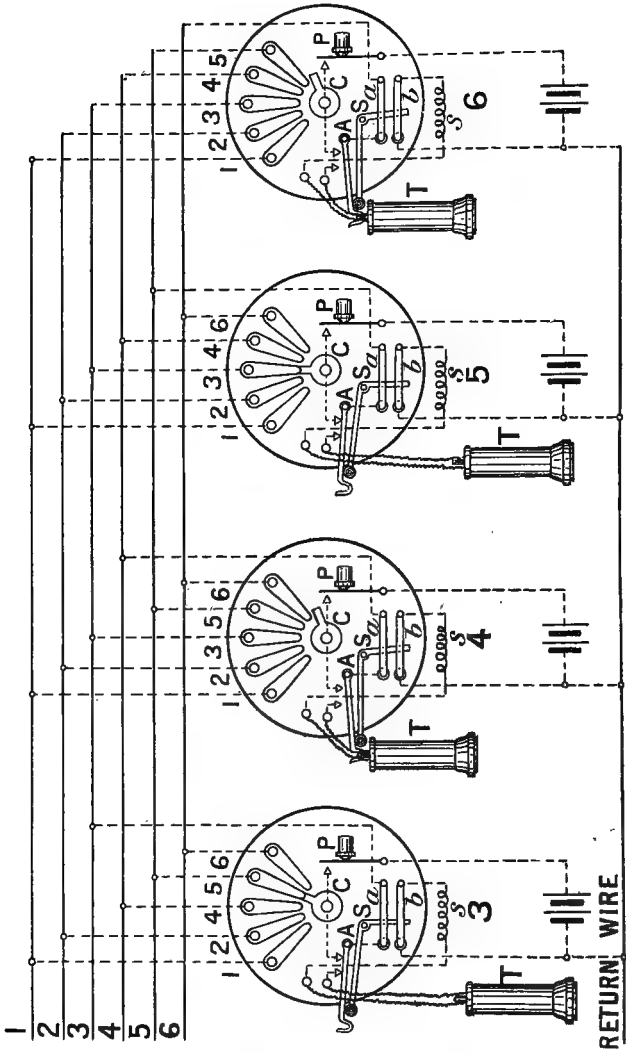

Fig. 284.

Suppose, now, that No. 3 calls No. 5 in this manner; that No. 5 replies, and is told that No. 3 wishes to speak privately; No. 5 thereupon turns his switch to "3," and Nos. 3 and 5 both lift their "secret switch" *s* to the position shown in the figure. Springs *a* and *b* are thus lifted from their contacts and electrically joined. The return wire is now discarded, and the circuit may be traced from telephone 3, through the automatic switch A, the cam C, line 5, springs *a* and *b* of No. 5 switch, No. 5 secondary coil *s* and telephone T, the automatic switch and cam C, back through line 3 to No. 3 switch, and so by way of the springs *a* and *b* through the secondary coil to No. 3 telephone. In effect, the circuit is made up of both correspondents' lines, instead of comprising the called-office line and the return wire. The replacement of the telephone upon the hook of the automatic switch also presses down the secret switch to its normal position. Of course the simultaneous communication between other offices, either by return wire or also on the secret plan, is not interfered with.

This is probably as near to a secret system as the domestic switchboard principle will admit of, but, inasmuch as any other office can switch on to *one* of the speaking lines (say, No. 6 switches on to No. 5 in the position shown), the "capacity" on the other side of telephone No. 6, namely, No. 6 induction coil, the return wire, and the whole set of ringing batteries connected to it, makes it quite likely that No. 6 would be able to overhear.

CHAPTER. XXVII.

SELECTIVE¹ OR INDIVIDUAL SIGNALS.

THE average user of a telephone circuit requires to employ the line for a very small proportion of the business day, so that when such a subscriber has sole use of a circuit it is idle for most of the time. If by any means a single circuit could be so placed at the disposal of several such subscribers that the efficiency of the service to each was not materially reduced, a considerable increase in the earning power of the line, and a more or less corresponding reduction in the expense, would obviously result. There are, of course, subscribers who use their wire almost continuously, and these must necessarily have a circuit entirely at their disposal; but the average subscriber does not exceed ten calls per day, so that there appears ample room for the development of such a system, and the subject has proved a tempting one for inventors; but, although many theoretically good solutions have been devised, it cannot be claimed for any of them that they have satisfactorily met the practical requirements of the case.

One important source of difficulty in this connection

¹ This term is adopted from a paper read by Mr. Thos. D. Lockwood (Trans. Am. Inst. Electrical Engineers, June, 1892, vol. ix.), from which some of the historical references in this chapter are also taken.

is the fact that the telephone circuit is for the use, not only of trained operators, by whom any special instructions are easily understood, but also for people for whom, from their position or from their lack of technical training, simplicity of working is an essential condition of usefulness. Herein lies the primary difference between the application of several stations to a telegraph circuit and a similar application in telephony.

The conditions required for a good selective signal system are :—

1. The exchange operator must be able to call any required subscriber on the "omnibus" circuit without disturbing any other.

2. Each subscriber must be able to call the exchange without disturbing the others.

3. It must be impossible for any subscribers on the circuit to overhear or to interrupt a conversation in which they are not engaged.

4. The subscribers of the omnibus circuit must be able to inter-communicate, either with or without assistance from the exchange (preferably without).

It has been assumed in the above conditions that there is a central or controlling office; but this, of course, need not necessarily be the case if only the group of subscribers on the one selective system are concerned.

The idea of selective signalling, either in principle or in fact, was involved in many telegraphic devices long before the invention of the telephone. The following may be mentioned as instances of inventions made with the precise object.

H. and E. Highton, in 1848, patented a device based upon combinations of several lines, two or more of which should extend from a terminal to two sub-stations.

The principle of this circuit-arrangement device, in its later development, may be explained by aid of fig. 285, in which ten main lines, by being made to intersect each other at some one sub-station, afford means of independently signalling any one of 45 sub-stations. For instance, station No. 37 might be called by using lines

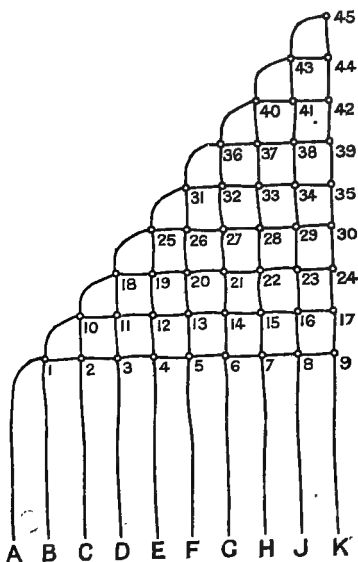

Fig. 285. Principle of Circuit-arrangement Calling System.

For instance, station No. 37 might be called by using lines F and H. If n be the number of lines, then the number of stations that can be selectively signalled on this plan would be $\frac{n^2-n}{2}$. No unusual apparatus is required for the system, which has been applied in many different ways.

Again, in 1850, E. Highton proposed the use of two wires, with currents of varying strength, and in both directions.

Wilde, in 1863, protected the device of a step-by-step movement, excluding or including, by means of insulated segments on a metallic disc, any telegraph station or stations as required.

The idea of synchronised clocks at each end of a main line, by which it would be connected by certain branch lines to sub-stations at the two ends for definite times, was first put forward by De Bonneville in 1865.

As already stated (p. 139) Bizot invented a plan for selectively ringing bells by means of pendulum hammers adjusted at each station to a different length.

Further, as is very suitably pointed out by Mr. Lockwood, the principles which govern printing telegraphy are also closely related to selective signalling.

In spite, however, of the large amount of labour that has thus been devoted to the general development of the matter, and the attention that its special application to telephonic practice has secured, selective signalling has not yet proved its claim to recognition for practical working conditions.

A few representative systems of the large number that have been practically employed to a limited extent may, however, be explained.

(a).—*ADER'S SYSTEM.*²

This system is adapted to metallic circuits, and has been used to some extent in Paris. It allows of four independent subscribers to an exchange being placed on a double-wire circuit.

The coils of a polarised relay at each station are in circuit on one of the lines, and the other line is completed through the automatic switches of the telephones. Between the relays at stations II. and III. the former line is put to earth through the tongue of a relay. When the operator at the central station wishes to call either of the four subscribers, he disconnects one of the two wires and sends into the other a positive or negative current, which, according to the line chosen and the direction of the current, actuates one of the four relays. When a subscriber unhooks his telephone the metallic

² "Journal Télégraphique," vol. xi., p. 189.

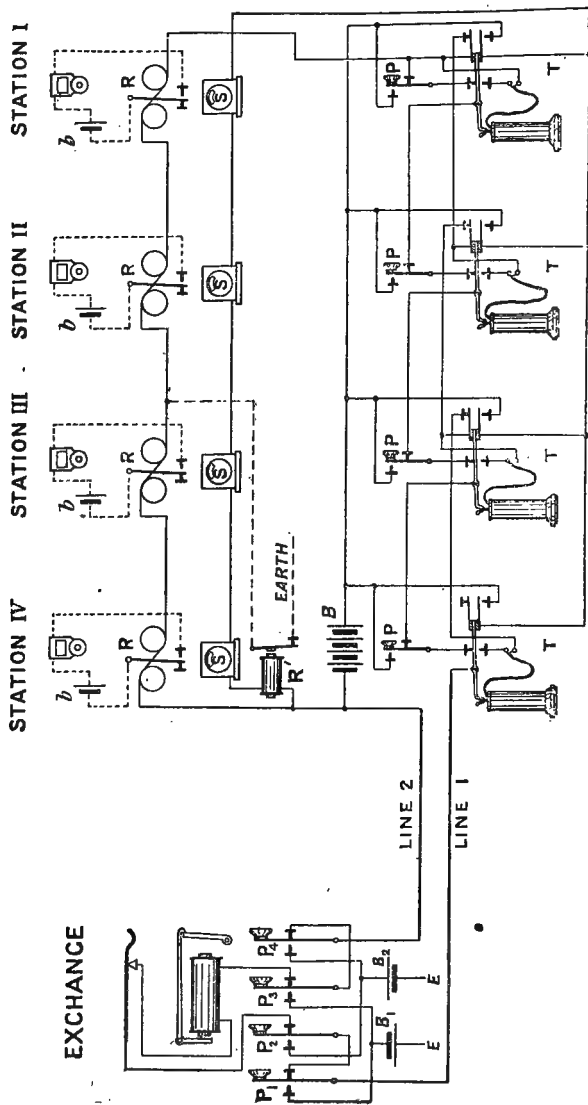

Fig. 286. Ader's Selective Signal System for Four Stations.

circuit becomes complete throughout, the earth is disconnected, and telephonic conversation can take its regular course.

At the exchange, in addition to the usual switch connections, the line is specially fitted with the four press-buttons, 1 to 4 (fig. 286); and the indicator is inserted in the circuit as shown, so that it is actuated whenever any one of the four stations calls.

When either of the subscribers is required to be called, the exchange operator has only to depress one of the buttons $P_1, 2, 3,$ or 4 . By the depression of P_1 a negative current from battery B_1 is sent to line 1, and line 2 is disconnected. By the depression of P_2 a positive current is sent to the same line from battery B_2 while line 2 is disconnected. In the same way negative and positive currents respectively pass to line 2 by the depression of P_3 and P_4 .

A call-current from a subscriber passes from line 1 by way of press-buttons 1 and 2, through the indicator, and the switch-springs, and so back to line 2 through P_3 and P_4 .

On receiving a call the operator at once places the telephone in circuit, and is thereupon in communication with whichever subscriber has called.

Turning now to the four subscribers' stations, I. to IV. The apparatus at each of these consists of a special telephone set, including, besides the transmitter, receiver, and call-bell, a special automatic switch, a press-button P , an indicator S , and a polarised relay R . The local circuit of relay R' normally joins line 2 to earth between the second and third stations. The call from the exchange traverses the following circuit: On P_1 being depressed a negative current passes through line 1, and

traverses first all the automatic switches and press-buttons *P* of the four subscribers' stations; it then passes through the coils of relays *R* at the two stations *I.* and *II.*, and so by way of the armature of relay *R'*, it goes to earth. Of the relays *R* at the two stations *I.* and *II.*, that at station *I.* responds to negative, the other to positive, currents; at station *I.* the circuit of the local battery *b* is therefore closed, and the station is called. When the operator at the exchange depresses button 2, the current traverses exactly the same path; but it is positive, and consequently actuates the relay of station *II.*, and not the other. By depressing the buttons 3 and 4 at the exchange negative or positive currents are sent into line 2, traverse the coils of the relays of stations *III.* and *IV.*, and return through the local circuit of *R'* to earth. The negative current actuates the relay of station *III.*, the positive current that of station *IV.* When one of these subscribers—let us say *III.*—is called, he unhooks his telephone, and thereby completely alters the connections. First of all, contact is made between the positive pole of battery *B* and the lower spring of the automatic switch, and by this contact a current from the battery traverses the four indicators *s*. A double purpose is effected by this current. On the one hand the armature of *R'* is attracted, and the earth-connection of the system thereby interrupted; on the other hand, all the indicators which originally showed a disengaged signal now show that the line is engaged. The circuit from the exchange is by way of line 1, the automatic switch and press-button at station *IV.*, the automatic switch and telephone of station *III.*, and thence, by way of the upper automatic switch spring and contact at stations *II.* and *I.*, through the relays *R* at all stations to line 2. It is impossible

to overhear the conversation, for if another subscriber—for instance, No. II.—were to unhook the receiver the circuit would be broken between stations II. and III. When the conversation is finished and the telephone again suspended, all return to a state of rest. The indicators again show the disengaged signal, and line 2 is again connected to earth between stations II. and III.

When one of the subscribers depresses button P the current passes from the positive pole of battery *B* through the press-buttons and the automatic switches of the stations to the left by line 1 to the exchange, and thence by way of line 2 back to the negative pole of *B*.

The relays R and indicators S are polarised, but they are not electro-magnetic; a flat coil moving between the poles of a very strong magnet takes the place of the usual electro-magnet. According to the direction of the current this coil is attracted by one or the other pole, and closes the circuit of battery *b*, or changes the disc of indicator S. This coil without iron core presents the advantage of introducing very little retardance into the speaking circuit.

The working of Ader's system is most simple. Each subscriber effects his call as if he were the only one in the circuit. At the exchange also no complication arises; and secret conversation is ensured. On the other hand, some drawbacks must be noticed. Of course when one subscriber converses with the exchange or a subscriber beyond, the other subscribers on that line cannot communicate, but they can disturb the conversation by pressing their buttons or unhooking their telephones. Further, there is the grave objection that these subscribers cannot intercommunicate in any circumstances; and, finally, there is the very serious point

that the system requires at least six wires making the circuit of the four subscribers, so that for economical reasons it is usually applied only where the four stations are situate in the same building.

(b.)—ERICSSON'S AUTOMATIC SWITCHBOARD.

The essential principle of an automatic switchboard is the use of a single circuit between the controlling station (the exchange) and a distant point from which various subscribers' lines branch off. The number of branch lines is necessarily limited, as otherwise the automatic switchboard would become very complicated.

The Ericsson switchboard, represented diagrammatically by fig. 287, is intended for five subscribers, and works entirely automatically at the point from which the subscribers' wires radiate from the single line wire.

The switch is of the step-by-step type, having a dial to five insulated points on which the subscribers' lines 1—5 are connected, and over which moves a pointer shown in the figure as turned to "3." In its vertical (zero) position the pointer makes connection with five other contact-points, *a—e*. The forward movement of the pointer is effected through the armature of the electro-magnet E_1 , each complete movement of which takes the pointer one step forward. The pointer is restored to zero by a single movement of the armature of E_2 . Each of these electro-magnets has a resistance of 200 Ω . Below the dial is fitted a so-called "galvanometer" *G*, which is practically a slow-acting relay having a neutral position. The tongue is connected to earth, and one end of the coil is joined to the exchange line. The resistance of this coil is 25 Ω .

Beneath the galvanometer is a series of five polarised

relays of special construction, three only of which, L_1 , L_2 , L_3 , are shown in the figure. The resistance of the coils of these is 1,750 Ω . The normal position of the

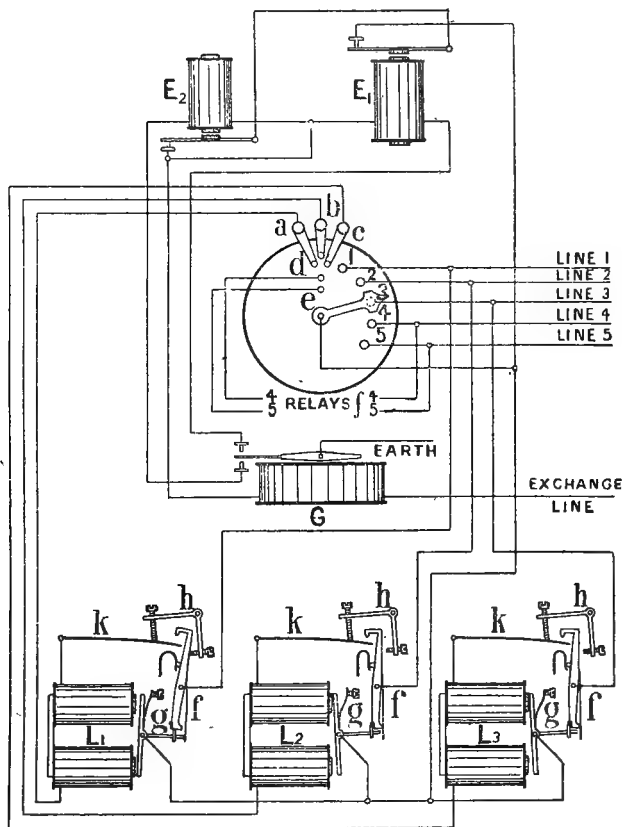

Fig. 287. Connections of Ericsson 5-line Step-by-step Selective Call-switch.

armatures and levers of these relays is shown by the separate diagram, fig. 288. On the lever, f is an in-

insulated stop, beneath which rests a projection from arm g ; which is fitted to the armature. A spring tends to push the lower end of lever f to the left, but the projection on arm g ordinarily prevents this; while, on the other hand, as soon as a current moves the armature over so that the end of f is free from the detent on g , it immediately moves to the left, and the armature is thereby prevented from returning to its normal position, and is at the same time electrically connected with a contact-spring on f , through the arm g . The armatures of all the electro-magnets, and, consequently, the arms g , are all connected together, and to the axis of the dial-

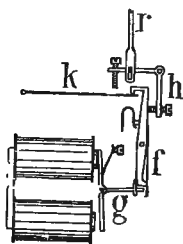

Fig. 288.

pointer and the back-stop of the electro-magnet E_1 . The bell-crank levers h have a common axis, so that they all move together, and in their normal position their vertical arms rest by an insulated stud against the levers f , while the contact on their horizontal arm is just clear of the light springs k , the end of which

normally makes contact with f .

In order to call either of the subscribers, the operator at the central station sends a series of positive currents from a battery of from 35 to 50 Leclanché cells. These currents pass through the coil of G , the contacts and levers of E_2 and E_1 , to the axis of the pointer on the dial, and thence by way of the contacts $a-e$ and the coils of the five relays L_1, L_2 , etc., through the subscribers' lines, to earth. The direction of the current is such that it does not affect the armatures of the relays; and, being a direct current, neither does it ring the magneto-bells at the subscribers' stations; its whole effect, therefore,

is to actuate the "needle" of G, which it deflects to the upper stop. This needle is very heavy; it is composed of three rods of magnet steel, and is maintained in neutral position by a strong directing magnet and a brush of badger-hair rubbing against a steel rake. Its motions are, therefore, relatively slow, and, in returning to its position of rest, it is scarcely deflected beyond it, being gently arrested by the brush. Moreover, having reached the limit of its movement, it remains in contact for about a second. By means of the upper contact a new circuit of low resistance through the coils of E_1 is completed, and the current, by passing that way, causes the attraction of the armature of E_1 . This armature is connected with a ratchet wheel on the axis of the pointer, and its movement, therefore, causes the pointer to advance by one step, so that it is brought to position 1, and is in connection with the first subscriber. By this movement the exchange line is through to subscriber No. 1, by way of G, contacts and armatures of E_2 and E_1 , and the dial-pointer; while none of the electro-magnet coils of the relays are in circuit. The central station or subscriber No. 1 can call one another by means of the magneto without disturbing anybody, for the galvanometer is not actuated by these reversed currents. The other four subscribers are disconnected, and can neither disturb the established conversation nor overhear it.

If, instead of requiring the first subscriber, the central station wishes to call another, a corresponding number of positive currents is sent to line, and the pointer is thus brought into the required position.

To restore to the normal condition, the operator sends a negative current of about two to four seconds' duration. The needle of G is thereby deflected to the

left, and completes the circuit of E_2 through the lower contact. As soon as the armature of E_2 leaves its back-stop, the subscriber's line is broken, and the entire current passes through E^2 . By the attraction of the armature the ratchet wheel of the pointer is left free, and it at once returns to its zero position by the tension of a spring, which has been wound-up by the advance of the pointer. Thus the whole apparatus is restored to the normal condition.

Now suppose that subscriber No. 1 wishes to call the exchange. By a turn or two of his magneto-generator alternating currents are sent through line 1, and pass by way of f , k (fig. 288), the coils of L_1 , the dial-contact a and the pointer, through the galvanometer coil G to the exchange line. For a very short period there is also a circuit through each of the other lines, but the movement of the armature of L_1 immediately brings about the change of connections that is shown in fig. 287. Contact is made between f and g of the relay L_1 ; and f presses back the crank-lever h , by which the contact between springs k and levers f is broken at each relay, as shown in the figure. All the electro-magnets are, therefore, out of circuit, and the current from line 1 can pass by way of f , g , and the pointer only to the exchange, where it passes through an electro-magnet. The needle of G does not move, and direct connection is made between the subscriber and the central station without the pointer leaving its normal position. The calling station can thus speak to the exchange operator, or be put through to another subscriber at will. At the conclusion of the conversation the operator sends a negative current to line, which actuates the armature of E_2 . The pointer is already at zero, but the movement of the armature lifts

a rod r (fig. 288), which acts upon a crank fixed on the same axis as levers h , whereby the levers are brought back to their normal position, and the armature of relay L_1 is also permitted to be restored by the action of its spring.

Suppose now that a subscriber wishes to speak with another subscriber whose line branches off from the same switch—if, for instance, No. 1 asks for No. 3; the central station, called by subscriber No. 1 and informed of the requirement, will send three positive currents to line, and thus place the pointer on 3, as shown in the figure (fig. 287). The two subscribers, Nos. 1 and 3, and the central station are now connected together. In order to restore the whole system to its state of rest on the termination of the conversation the central station will send a negative current, and the armature of electro-magnet E_2 will then fulfil both its functions: in the first place it will bring back the pointer to zero; and, secondly, it will restore the levers h to their normal position as indicated by fig. 288.

If fewer than five subscribers have to be connected with the central station, the dial-contacts not used are connected to earth through a resistance of 110 ohms.

(c.)—*JOHNSTON STEPHEN'S SYSTEM.*

Mr. Johnston Stephen applies to his system the principle of calling by means of pendulums of different length, first proposed by Bizot for the individual call of telegraph stations (pp. 139 and 389). In fig. 289 is given a diagram showing the complete arrangement of a subscriber's station, placed with a certain number of similar stations on a single wire. T is the micro-telephonic apparatus, and K the press-button; M is a polarised electro-magnet, whose armature can take up

two positions: the position of rest, d , when a current circulates through the line in the direction of the arrows, and the position d_1 , when this current is of opposite direction; s_1 is a lever, the two arms of which are insulated from one another, but are normally in contact with the insulated springs l and l_1 . Lever s_1 is pivoted, and a spiral spring tends to pull its upper

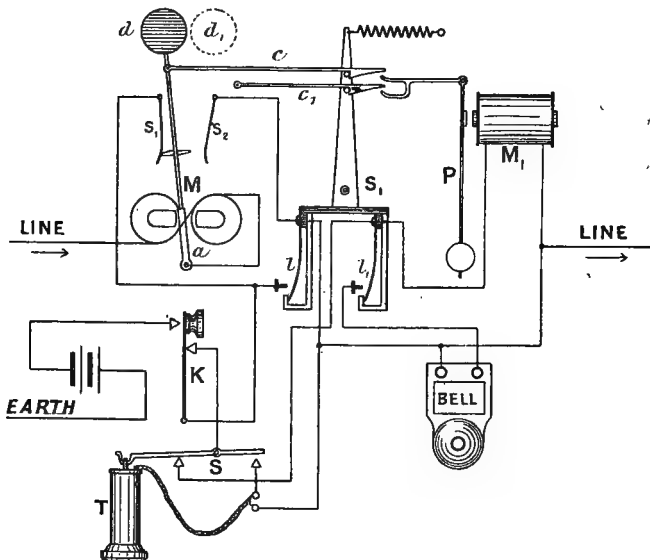

Fig. 289. Johnston Stephen's Pendulum Selective Signaller and Cut-out Switch.

arm to the right, but it is normally kept in a vertical position by two hooks c and c_1 . The pendulum P has a different length, and therefore a different rate of vibration, at each station; at its axis it carries a forked arm projecting horizontally. M_1 is an ordinary electro-magnet arranged to act upon an armature on the pendulum rod.

The operation of the apparatus by the call of the controlling station, and the mode of connecting this subscriber with another placed on the same or another wire, will be readily followed.

The subscriber calls the exchange (situated on the left, fig. 289) by depressing K . The current passes through s_1 , a , and electro-magnet M to line, and so to the exchange. It, of course, passes through the coils M_1 and M of the subscribers' stations which intervene between the calling station and the exchange, but only produces a very slight oscillation of the pendulum P . It cannot alter the position of the armature a , because it has not the proper direction. The communication between the central station and the subscribers situated on the right of the calling station is interrupted so long as the button K is depressed.

The subscriber unhooks the telephone, tells the exchange operator the number of the subscriber with whom he wants to speak, and again suspends the telephone.

The operator at the exchange singles out the called subscriber. For this purpose he has a sort of metronome to which he can impart the rate of oscillation of the pendulum of any subscriber (p. 137). This metronome, in performing its oscillations, sends intermittent positive currents to line, which do not affect the armatures a , but influence all the pendulums P ; that one only of the pendulums, however, whose rate of oscillation corresponds to that of the currents, gradually attains sufficient amplitude to raise the hooks c and c_1 , thereby permitting the lower part of lever S_1 to be drawn to the left by the action of the spiral spring. The intermittent currents from the central station now cause the bell to

ring at the station thus singled out by passing through the bell-coils instead of through M_1 .

The called subscriber unhooks his telephone, and is informed by the exchange that a certain other subscriber wishes to speak with him. After receiving this communication the telephone is again suspended.

The operator at the exchange then singles out the calling subscriber by the method previously employed, and sends a negative current to the line (or to the lines if the calling and the called subscribers are on different lines). All the armatures a hereby take up the position a_1 , and make contact with spring s_2 , but the detent c_1 , at all stations not required, maintains s_1 in its normal position. The movement of the armatures at the calling and called stations permits the detent c to again engage with the pin on the upper arm of s_1 .

By this movement of the armatures a , the discs d at all stations become visible, and indicate that the line is engaged. At the calling and called stations the bell rings to show that they are through; and at all the other stations the current passes through M , a , s_2 , and l , so that the telephone T and the button K are not in circuit, and it is therefore impossible for any of the other subscribers either to interfere with the conversing subscribers or to overhear their conversation.

When the conversation is finished one of the subscribers sends a current to the central station by depressing K , thus informing the operator that the line or lines can be restored to normal. The operator thereupon sends a strong positive current to line, which brings back all the armatures a to position d . At the stations that have been in communication a further result of this restoration of the armatures is to make the hooks c bring back the

levers S_1 to their normal position, as indicated in the figure, so that the whole circuit is restored.

Should the subscribers who have been in communication fail to send the ring-off signal, the rest of the subscribers are, of course, unable to call the central station; but it would be the duty of the operator there not to permit two subscribers to be through for any excessive period: after a reasonable time the restoring current should be sent, even if no ring-off signal has been given.

(d.)—POST OFFICE "SECRET" SYSTEM.

A very simple and efficient system, which provides for absolute secrecy in communication between any two offices on a circuit, is in use by the British Post Office.

It is not ordinarily arranged for selective signalling, but if needed this could be easily added; neither is it placed under the control of a certain office, its special feature being rather that any two offices shall be able to communicate without interference or overhearing, although no special system of working is employed.

Each office is provided with a complete telephone, fitted with a double press-button and an extra switch-lever, and having specially-arranged connections, a relay, and an electro-magnetic switch. The latter instrument (as indicated by fig. 290) is practically a relay with two levers actuated simultaneously and moving between independent contacts. In order that there may be no break in the circuit during the passing of the switch-levers from the normal position to the "front" contacts, prolonging springs are fitted to each lever. Further, a shunt-coil of 60 ω is joined across the electro-magnet coils so as to eliminate the effect of the "extra current" in the coils.

The battery for each office, where six offices are on the circuit, consists of twenty-four Leclanché cells, and these are so arranged that the current is always in the same direction. In the calling circuit at each office is placed a resistance of 450^{ω} to reduce the calling current.

In the normal condition the coils of both relay and electro-magnetic switch are in circuit at each office. The relay local circuit is for ringing the call-bell, and the electro-magnetic switch normally places the telephone instrument in circuit; but when the armatures are attracted, nothing but the coils of the switch can be in circuit. The connections of the telephone are such that on removing the tubes for speaking, a current is sent to line from the calling battery without the 450^{ω} resistance in circuit.

If, now, in the normal condition, any subscriber depresses the press-button of his telephone, the weaker current from the calling battery passes to line, and actuates the relay at each office. As already stated, pre-arranged signals are ordinarily used on this system; but, if required, the pendulum signaller (p. 137) could take the place of relay and press-button. The electro-magnetic switches are adjusted so as not to be actuated by the ringing current.

After the required correspondent has replied, he and the caller remove the tubes from the switch-rests, thus causing a strong current due to a voltage of forty-eight cells to pass to line. This current (more than double the ringing current) actuates the electro-magnetic switches at every office except the two concerned, and so cuts them out of circuit. It is thus absolutely impossible for a third party to intervene, as the first two who lift the telephone tubes at once cut out all other offices.

On the tubes being replaced in the rests, the normal condition of the circuit is automatically restored.

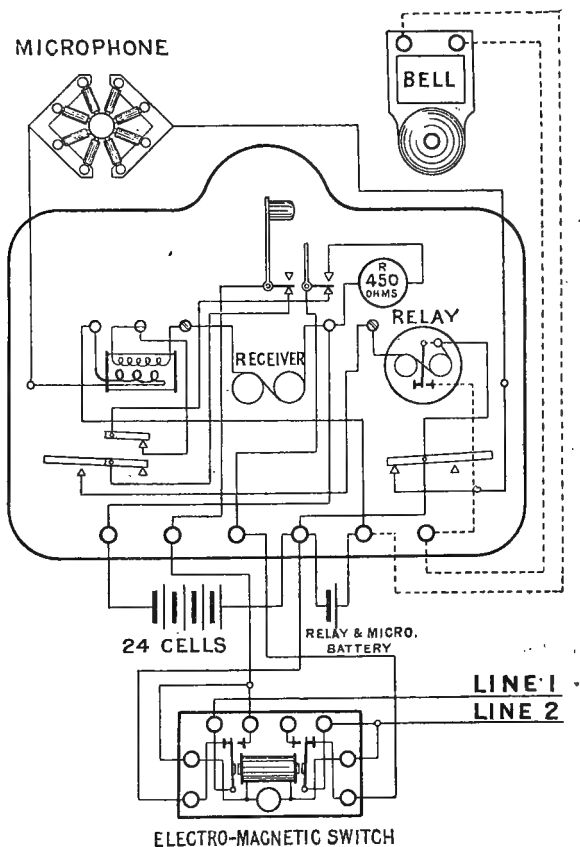

Fig. 290. Connections of Post Office Secret System for Multiple Office Circuits.

An intermediate switch (p. 165) can also be provided at any office, so that the circuit may be divided at that

point, and any two offices on each side of the switch can communicate simultaneously.

The "bridge" (chap. x) principle could very easily be applied to this system, but it is not found that there is any considerable demand for such special conditions as this was devised to meet.

PART VI.
CONSTRUCTION, WIRES AND CABLES.

CHAPTER XXVIII.

CONSTRUCTION OF LINES.

IT is not within the scope of this work to deal with the questions connected with the construction of lines except in so far as they affect the actual working of the telephone or involve important principles connected therewith.¹

In the early days of telephony the distances of telephonic transmission were so limited that the need of good insulation for the line could be, and very often was, considerably overlooked with no very serious results; but now that telephonic communication takes place over long circuits, good insulation is recognised as essential to satisfactory working. If this is neglected the result is sure to be bad. Every point of attachment of the wires must be looked upon as a more or less efficient earth-shunt. If the insulation be good, the shunted current is small; if bad, the latter increases, and on long lines will seriously reduce the intensity of the received sounds.

An even more serious effect of bad insulation is that when a number of wires are attached to the same support, more or less perfect connection is made between

¹ See "Telegraphy," by Preece and Sivewright; also "The Practical Telephone Handbook," by J. Poole.

them, so that with bad insulation it may happen that the leakage may become sufficient to allow of the conversation maintained on one wire being heard in the telephones of the neighbouring lines. If overhearing becomes more defined in wet weather than in dry, it most probably arises from defective insulation. Telephone circuits should therefore be insulated as carefully as possible with some approved form of porcelain insulator.

The distance between the insulators must be decided by the consideration that not even a strong wind shall cause an entanglement of the wires. Under the Post Office regulations the distance between the wires is either 12 or 14 inches.

At a very early stage in the practice of telephony it was found that a two-wire telephone circuit was much freer from disturbances than a single-wire circuit. The extreme sensitiveness and delicacy of telephones result in their being affected by currents due to leakage from other circuits, and also by the passing of varying "earth-currents" from one earth-plate to the other along the line. Moreover, when the two ends of a wire are led to earth, the two earth-plates, as a rule, are not at the same potential, especially where the two points have a different position with regard to the geological condition of the ground. A continuous current thus passes in the wire, which in itself has no effect upon the telephone; but if it become intermittent—for instance, through the variable resistance of a bad joint which is moved by the wind, or through variable insulation caused by rain, or through electrolytic action at the earth-plates—disturbances will ensue. These intermittent disturbances, which on a long line may

repeat themselves at very short intervals, are very troublesome, especially in wet weather. Such conditions produce the curious effect of one end of the line being perfectly quiet, while the other end is so noisy that conversation becomes impossible. This is frequently the case when atmospheric electricity is about. These effects can be largely eliminated by the plan of using a (return) wire making a metallic circuit and dispensing altogether with an earth-connection.

There is, however, another source of disturbance which is only partly counteracted by the use of two wires—namely, *induction*. The theory of this effect has been already explained in Chapter i. Now, assuming that both wires of a telephone “metallic circuit” are situated at the same mean distance from every disturbing influence, the currents induced in each will be precisely equal, and, as they will pass in the *same* direction, they will neutralise each other in the receiving telephone.

Thus, if two circuits be arranged with the four wires forming a perfect square at every point along their whole length (fig. 291), and there be no other disturbing influence in their neighbourhood, then, if the diagonal wires be taken in each case for one circuit, the mutual induction of the pairs will be neutralised: for it may be taken that the current induced in 1 by 2 will be balanced by that induced by 2 in the “return wire” 3, and similarly with the effect of 4 upon 1 and 3 respectively.

These conditions, however, do not generally exist in practice—the disturbing causes are more or less numerous and beyond regulation; so that the problem

of maintaining both wires of a circuit at a mean average distance from external disturbing sources is not so simple. A complete solution where a limited number of telephone wires is involved was devised by Professor Hughes. It consists in causing the wires to twist as it were like the strands of a rope. This plan was first put into practice by the late Mr. Charles Moseley² between Manchester and Oldham. It is now carried out in the manner shown in fig. 292. It will be observed that the wires make a complete revolution in four spans of the line, so that they are brought to the same average distance from all external disturbing influences; such, for instance, as a working telegraph circuit which is run straight, as shown in the figure. Thus, the disturbing influence of the telegraph wire upon the spans A, B, C, and D of one wire of one of the two telephone circuits is exactly counteracted by the same disturbing influence upon the corresponding spans *a*, *b*, *c*, and *d* of the return wire. The full lines represent one circuit and the dotted lines the other.

The following plan has been adopted as a means by which the individual wires on a twisted line can be readily identified at any point. Every pole or other support in each testing section is numbered consecutively, and a diagram showing the positions of the several wires upon each of the first four poles is supplied to the linemen who deal with that section. These diagrams are made as indicated in fig. 293, for lines numbered 1, 2, 3, and 4; of which, of course, 1 and 3 and 2 and 4 would be the two circuits. Then at every pole throughout the section whose number is divisible

² British Patent Specification 2,690 (July 1, 1880). This is issued to Charles Moseley, W. F. Bottomley, and W. E. Heys.

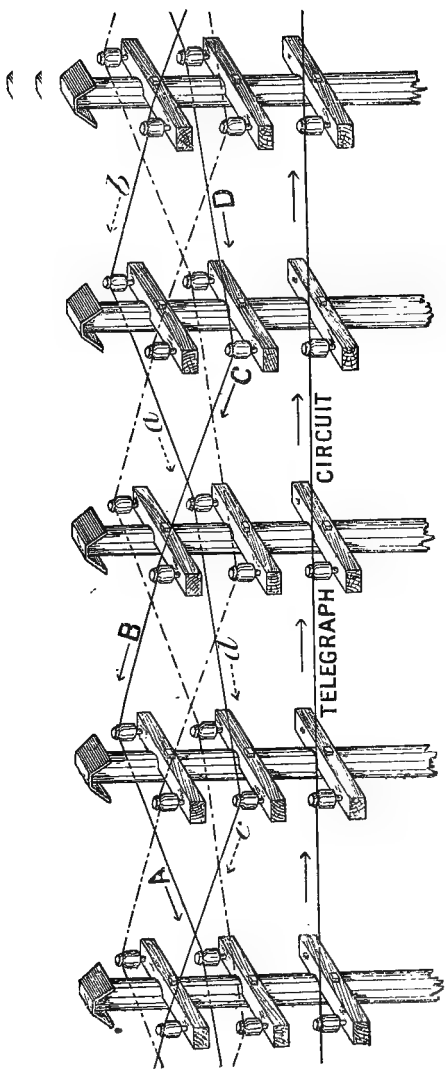

Fig. 292.

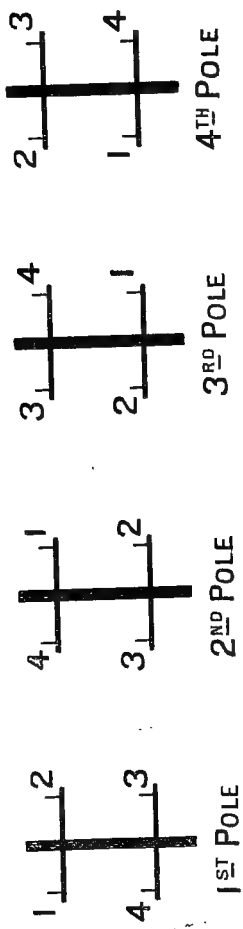

Fig. 293.

by four without remainder, the wires will occupy the same relative positions as upon the fourth pole in the diagram; but if the number of a selected pole when divided by four leaves a remainder, the positions of the wires will correspond with those which they occupy upon either of the three first poles in the diagram, according as the remainder is 1, 2, or 3. Thus, pole No. 543 gives a remainder of *three*, therefore the positions of the wires upon that pole will be the same as on the third pole in the diagram.

If additional supports are subsequently inserted the symmetry of the twist must be maintained as far as possible. When *one* support is added, thus forming two spans out of one, the shorter of the two should be run straight, so that the minimum length may be exposed to external inductive interference.

When *two* supports are inserted, forming three spans, two of them must necessarily be run straight, and the desirability of the shortest spans being selected applies in this case also.

Where, however, *three* extra supports are necessary, it would generally be advantageous to insert *four*, by which means the twist will not be interfered with. Of course some suitable distinguishing mark or number must be given to all additional supports.

When new lines are in course of erection, or when sections are being re-built, no such provision is needed. So long as the same direction of twist is observed, sections may be commenced at any point; because, as will be seen from fig. 292, the wire from the upper left-hand insulator in all cases goes to the upper right-hand at the next pole; that from the upper right-hand insulator goes to the lower right-hand, and so on. All sections

will, therefore, combine in a regular twist when they come to be joined.

As regards the general question of the erection of twisted wires, it is extremely important that all the spans shall be as nearly equal as possible. When, however, it happens that, for construction purposes or other reason, it is necessary to depart from the average distance at some points on a line, there is no objection provided that the altered distance be made to apply to a complete revolution of the wires. Thus, if the distance must necessarily be short between poles 542 and 543 (which may be called span "3," because of the remainder from $543 \div 4$), then it should, if possible, be arranged that spans "1," "2," and "4," either adjacent to the necessarily short span or within a distance of, say, a mile, should be correspondingly short.

The "symmetrical twist" system is unquestionably the most efficient means of overcoming inductive disturbance that has yet been devised. It is sometimes objected that the wires are more subject to contacts, but this is not borne out by the experience of the Post Office engineers, who have a very extensive system of both twisted and straight wires under their control; and, although the tracing of faults is rendered somewhat more difficult, the linemen after a little practice manage very well in that respect. It must be admitted, however, that, in the case of a breakdown, the difficulty of restoring communication is rather increased. A further objection raised is that so many twists (seven or eight to the mile) are not required to ensure silence; but this objection loses a great deal of its force by the consideration that different external sources of disturbance may be present along different sections of

the circuit, so that the balance is very liable to be upset by reducing the number of twists. However, for telephone trunk lines where telegraph circuits do not come into question the "cross-over" system is very successful, and is largely used.

On this plan the wires are run straight on the poles in the usual way, but are terminated at certain points upon poles fitted either with double arms or with double brackets fitted upon the arms as shown in fig. 294.

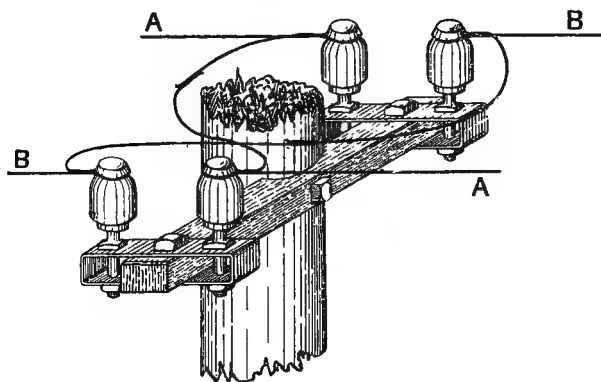

Fig. 294.

The crossing-over is sometimes effected by rigid connections bound to the line wire, one being straight across and the other curved over or under the straight piece; but a better plan is to leave tail-pieces to the line-wires beyond the binding, which are lapped together like an ordinary joint. This method, indicated in fig. 294, has the advantage that it avoids additional heating of the line-wire at a point where it is subject to stress.

Several pairs of wires may be run on one arm, the crossing-points of all being, of course, at the same poles. In America ten wires on an arm is a customary

number. In order to secure neutrality, the wires on the next arm should be crossed midway between the crossings on the upper arm, and so on with the others. This is indicated in fig. 295 by the three circuits A, B, and C. The points of crossing should be carefully calculated in order to ensure silence; they are not

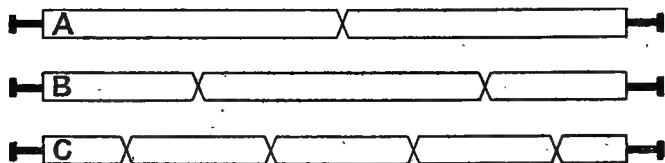

Fig. 295.

necessarily equidistant, but must be so spaced that equal sections of each wire of the circuit shall be at the same average distance from each external disturbing cause. Thus, in fig. 296 a cross is made midway

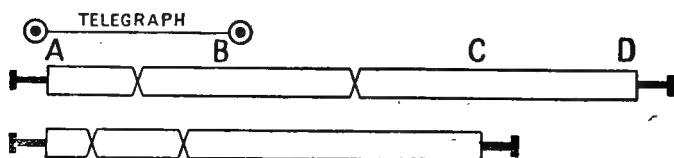

Fig. 296.

between A and B on a circuit A D, so balancing the induction from the telegraph circuit, while a double cross between the same two points on circuit A C, and another cross upon A D, midway between B and C, provide against mutual induction between the two telephone circuits as well as for the effect of the telegraph circuit upon A C.

The plan adopted in France, on the London-Paris telephone line, secures a complete revolution of the

wires at every *sixth* pole instead of at every fourth pole as in the symmetrical twist system: but there is reason to believe that these wires are not so free from external disturbance as is the English section of the same line.³ The wires are twisted in pairs, upon arms of varying lengths so disposed that the wires maintain an average distance. Fig. 297 shows this arrangement diagrammatically. The object of the French engineers was to avoid the crossing-over of the wires between poles, as they feared contact troubles from wind, etc., with the symmetrical twist. It is found, however, that the average of faults on the whole line is about equally distributed between the two administrations, length for length, and "wind-contact" is altogether unknown.

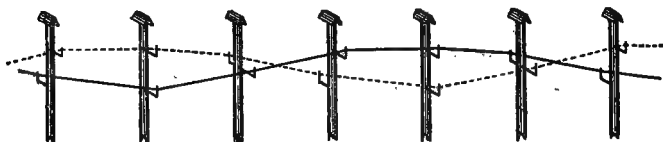

Fig. 297.

Another consideration which is of very great importance for telephone lines is the *sag*, or *dip*, of the wires between two supports. Very much depends on the care and accuracy with which copper wire is erected. Until copper wire came into such general use it was customary to regulate the sag of iron wires by reference to a dip of 24 ins. in 100 yards, and to vary this for different spans and temperatures by reference to tables; but foremen were governed very much by rule-of-thumb, and regulated simply by eye. This, however, with an increasing number of men,

³ W. H. Preece, British Association, August, 1891.

many of whom are necessarily not very experienced, is liable to lead to grave defects, especially with copper wire, or where copper and iron are both used on one line of poles. A more exact system has therefore been introduced. The stretching of the wire is at first accomplished as far as possible by hand. The wire is then gripped by means of a species of vice, known as

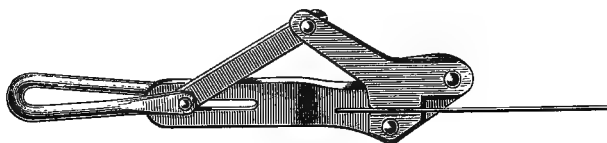

Fig. 298.

draw-tongs (fig. 298), and, by means of light blocks and tackle, is drawn about as tight as it is required. Finally, the actual stress to be put upon the wire is determined by means of a *dynamometer* or *tension-ratchet* of the form shown in fig. 299. One end of a strong wire is attached to a pole or some fixed point and the other

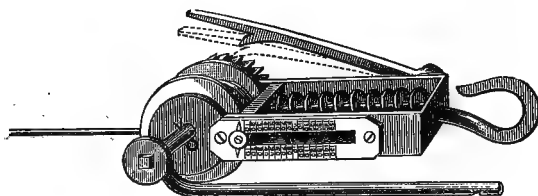

Fig. 299.

to the drum of the tension-ratchet. This drum is fixed across the end of an iron frame, and is provided with a ratchet-wheel acted upon by a suitable pawl. On this frame is arranged a graduated spring-balance with a hook. The wire which is to be strained-up is gripped at a convenient point by the draw-tongs, which is hooked

to the tension-ratchet by the loop. On revolving the drum by means of the key, and so winding up the cord, the tension on the wire is increased until the indicator shows that the proper stress is being applied. If the wire is pulled up too tightly it is very likely to break under very little extra stress; if it be left too slack, it is liable to get into contact with the others in its neighbourhood: both extremes must be carefully guarded against.

If one wire upon a line of poles is once properly regulated, the regulation of all the succeeding wires that are run may be taken from it, and becomes a very simple matter: for (assuming that they are all of the same metal) they will all, even if they are of different gauges, take exactly the same sag with the same proportional stress.

It is, however, a good plan to adjust and bind-in all the wires on an arm (or in a "square") simultaneously, as the stress of the wires tends in some measure to modify the condition of the supports.

The tension-ratchets have proved of great value since their introduction, and copper wires are now invariably regulated by their aid, as also are iron wires if it is likely that copper wires will be run on the same poles.

The variation in the length of wire in a span, owing to changes of temperature, necessarily has the effect of varying the stress on the wire; this, therefore, has to be provided for in erecting wires, and, in connection with the introduction of the tension-ratchet, or dynamometer, just referred to, the British Post Office has issued a Table, which is given below, and which shows the corresponding sags and stresses of iron and copper wires under varying temperatures.

In drawing up these Tables the following formulæ were employed:—

$$d = \frac{l^2 w}{8s}; \quad d = \sqrt{\frac{3l(L-l)}{8}}; \quad L = l + \frac{8d^2}{3l}; \quad s = \frac{l^2 w}{8d}$$

$$d_1 = d \sqrt{\frac{L(1+kT)-l}{L-l}}; \quad s_1 = s \frac{d}{d_1}$$

where

- l = span.
- d = sag (or dip) at minimum temp.
- d_1 = sag (or dip) at higher temp.
- s = stress at minimum temp.
- s_1 = stress at higher temp.
- w = weight of unit length.
- L = length of wire in span.
- T = difference of temperature.

Also,

w for 400 lbs. Iron	=	·075758	lb. per foot.
„ 150 „ Copper	=	·028409	„ „
„ 100 „ „	=	·018939	„ „

and

Co-efficient of expansion k for Iron	=	·0000683	per deg. F.
„ „ „ Copper	=	·0000956	„ „

The minimum temperature is taken at 22° F. Ordinary winter temperature may be taken at 40° F., average summer temperature at 58° F., and the temperature of a hot day at 76° F. The column headings are intended practically to serve the same purpose as the use of thermometers, which would probably not, as a rule, record the actual temperature of a wire in course of erection.

The stress, as measured by the dynamometer, should in all cases correspond with that shown in the Table for a given conductor and average span under the temperature prevailing during the erection of the wire. The stress, as already stated, will vary for different

spans at the same temperature, but for any given line the figures opposite the *average* span and temperature are those employed in practice.

Sags and stresses for copper and iron wires do not vary in the same ratios under changes of temperature, owing to copper having a higher coefficient of expansion than iron. With spans of less than eighty yards the difference is not so great as to render it unsafe to run iron and copper wires together; but, as spans increase beyond this length, some danger of contacts may arise, and a slight departure from the tabular results may then be permitted to obviate this difficulty. For example, in special instances the copper may be run with a smaller or the iron with a greater dip. It is, however, better to avoid long spans where copper and iron are used on the same poles.

It will be observed that the variations in sags and stresses under changes of temperature are much greater in short spans than in long ones; the stresses between the low winter and high summer temperature with a copper wire being reduced in the ratio of about 2 to 1 with a 100-yard span, while the reduction is nearly $3\frac{1}{2}$ to 1 in the case of a 50-yard span. One thing to be learnt from this is that to avoid ultimate excessive winter strains much more care is necessary in the erection of short than in that of long spans.

It will be seen also that, although the stress at one temperature may be uniform throughout, yet, as the temperature varies, it appears that the stresses in neighbouring spans of different lengths must vary also. This would undoubtedly be so if the supports were rigid, but in practice the stresses adjust themselves by a slight deflection of the poles or supports.

As, however, wires are usually erected in summer, it might still appear desirable where the spans vary, to vary the tensions, in order that the theoretical conditions should be actually complied with. But with the existing method of erecting wires this is impossible, and it is not really necessary, for, in practice, on well-designed main lines the variations in spans are not usually great, and, if the stresses opposite the average length of span for any given line be employed, no material error will result. Thus on a heavy line of 30 poles to the mile the stresses for 60-yard spans should be used throughout. The result would be that the theoretical stresses at 22° F would be somewhat higher for the spans *under* 60 yards, and somewhat lower for those *over* that length than is shown in the tables. These stresses would, however, in practice, readily re-adjust themselves by deflecting the poles as indicated above.

One factor which modifies the variations due to temperature is the elasticity of the wire. The effect of elasticity under the increased winter stresses is to lengthen the wire and so tend to maintain the normal sag. As hard copper wire is very elastic within certain well-defined limits, the effect of elasticity is more marked with this metal than with soft iron.

Elasticity has, however, been designedly neglected in the Tables. The result of this omission is that new lines erected in summer will have a larger factor of safety at low winter temperature and somewhat greater sags than the Tables indicate.

In erecting wires on new poles some discretion must be exercised in the application of the Tables. For instance, if the line is built rigidly—*i.e.*, if all poles at angles and curves are strutted and stayed—the stresses

given in the Tables may be employed. If, on the other hand, as sometimes happens, that which will ultimately be a heavy line is erected for two or three wires only, and the strutting and staying is consequently deferred till the necessity for such strengthening is actually felt, then an extra stress of 10 or 20 per cent. may be put on at angles to allow for the pulling over of the poles as they take their permanent bearing in the soil. On long straight lengths this allowance is, of course, unnecessary.

The dip is sometimes determined by means of a graduated ruler, which is held up in the centre of the span on a level with the two points of attachment. The wire is then slackened until it shows the desired dip on the graduated ruler. It is often difficult, however, to do the necessary sighting—for instance, when the span leads over a valley or a river. In such cases the requisite dip is measured vertically downward on the two supports from the points of attachment, and the wire is adjusted until its lowest part touches the sighting line between the two points. The plan of measuring the stress by means of a dynamo-meter is, however, unquestionably superior, both as to convenience and practical results.

The stress on a wire may be greatly increased by the deposition of snow and ice. These deposits often form cylinders of considerable dimensions. The specific gravity of snow is $\cdot 12$, and that of ice $\cdot 92$, so that for a mixture of both, of which these deposits are generally formed, we may assume a specific gravity of (say) $\cdot 3$. A deposit of 254 mils in thickness will, therefore, with a 112 mils diameter copper wire (specific gravity 8.9), be sufficient to increase the weight (and consequently also the stress) twofold. It is observed that larger

masses of ice are deposited on a copper than on an iron or steel wire, which observation, as might be expected, agrees with the difference of specific heat of the two metals.

Bad joints in the wire may become a very fruitful source of trouble, especially as the faults to which they give rise are very difficult to trace. The form of joint now almost universally used is shown in fig. 300. It was introduced by Mr. Edwin Clark, and is known as the "Britannia" joint. The ends of the wires are carefully scraped clean, laid side by side for a certain distance, and then bound together with 50 lbs. tinned copper wire in the manner shown. Electrical continuity is

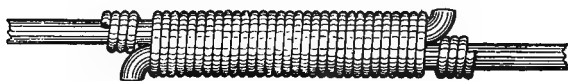

Fig. 300.

secured by soldering; either chloride of zinc or "Baker's Fluid" ⁴ being used as the flux.

The continued application of heat seriously weakens copper wire, so that quick soldering is absolutely essential, otherwise the wire is nearly sure to break at the joint. In order to avoid the risk of weakening the wire in this way, the plan has been adopted in Germany of securing a soldered electrical connection by bending back the ends of the main wire after the joint has been made and soldering them. By this means no heat is applied to the actual joint; but the effect is not very slighty.

American practice rather favours the "McIntire" joint. This consists of two copper tubes, of a size suit-

⁴ Baker's Fluid is prepared from zinc, hydrochloric acid, and ammonia.

able for the wires that are to be joined, brazed side by side. Into these tubes, from opposite ends, the line-wires are passed, the ends turned up and cut close. By means of special pliers the two tubes are then twisted together. No solder is used, the twisting itself ensures good electrical contact, besides increasing the mechanical strength.

The length and weight of 50 lbs. jointing wire required for the proper lengths of Britannia joints are given in the following Table, recently issued by the Post Office.

Size of Line Wire.	Length of Joint (overlap of Line Wire).	Jointing Wire (50 lbs. per Mile).	
		Length per Joint.	Weight per Joint.
lbs.	inches.	inches.	drams.
800	3	74	15
600	$2\frac{3}{4}$	64	$13\frac{1}{2}$
400	$2\frac{1}{2}$	48	10
200	$2\frac{1}{4}$	36	8
150	2	30	7
100	$1\frac{3}{4}$	26	6

On the basis of these determinations, together with the specified minimum weight of one coil of line-wire, the weight of jointing wire required per mile and per ton of line wire is in accordance with the Table given on p. 428.

As the calculations have been made for a number of joints corresponding to the specified *shortest* length of line-wire that is accepted from manufacturers (a minimum weight per coil of 80 lbs. for sizes over 200 lbs.,

and 50 lbs. for 200 lbs. and under, as shown by the Table on p. 446), very little further margin is likely to be needed. This margin has been allowed, and the weights given will probably be found ample in any circumstances.

Size of line-wire (weight in lbs.)	800	600	400	200	150	100
Weight in ounces of jointing wire:—						
Per mile of line wire...	12	8	4	3	2	1
Per ton of line wire ...	32	30	20	24	24	20

The method which was originally employed in binding copper wire to the insulator is shown by fig. 301.

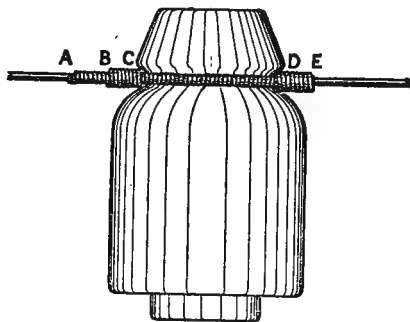

Fig. 301.

Two wires are whipped round the line-wire from B to E, thence back to D, then from the *upper* side of the line-wire they are taken around the neck of the insulator to the *under* side of the line-wire at C, back over the first layer to B, and then taken on as a single layer to A. The length of wire required in this case is 40 inches for

100 lbs. wire and 52 inches for 150 lbs. No. 17½ soft copper wire, weighing 50 lbs. per mile, was used.

In view of the use of very heavy wire, weighing in some cases 800 lbs. per mile for long trunk lines, the Post Office engineers considered it necessary to devise a stronger form of binder than that just described, and the plan illustrated in fig. 302 has accordingly been adopted. The line-wire at the insulator is first lapped round with copper tape 47 mils thick and of a width suitable to the size of the line-wire ; and the binder is then

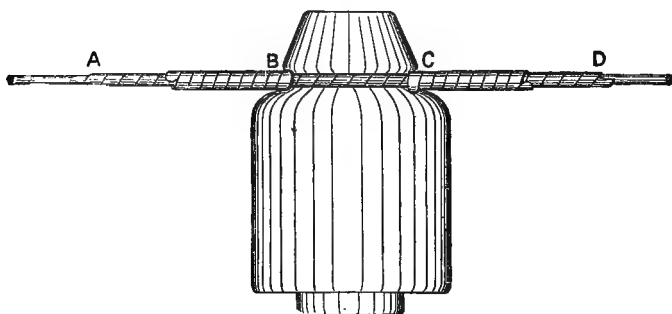

Fig. 302.

applied as follows :—It consists of a length of wire of a size somewhat smaller than the line-wire, with the ends rolled flat and the central portion curved to fit the neck of the insulator. The flat ends are wound over the protecting sheath upon the line-wire upon each side of the insulator from B and C outwards, the winding being effected by means of two pairs of suitable pliers. The sheath is arranged to project at each end from A to D, in order to protect the wire when a binder is being removed.

The tape is produced from round wire rolled flat so

that it has no sharp edges. Both tapes and binders are issued ready for use and are of the sizes shown by the following Table:—

Weight of Wire per Mile.		Length of Binder.	Copper Tape.	
Line.	Binder.		Length.	Width.
lbs.	lbs.	inches.	inches.	inch.
800	400	19	24	$\frac{1}{2}$
600	400	19	24	$\frac{1}{2}$
400	200	19	23	$\frac{3}{16}$
200	150	17	22	$\frac{5}{32}$
150	150	17	22	$\frac{5}{32}$
100	100	17	22	$\frac{5}{32}$

Suspension of Aerial Cables.

Aerial cables are rarely made strong enough to carry their own weight, so it is usual to suspend them from special wires, generally of stranded steel.

The following formula may be taken for calculating the size of wire required for suspending an aerial cable:—

Let w be the weight in lbs. per foot of the cable to be suspended, l the span in yards, s the sag (in percentage of l), and x the cross-section of the suspending wire in square inches; then, if the breaking stress of the suspending wire be about 28 tons per square inch, and the factor of safety is to be four, the area of

cross-section of the suspending wire in square inches will be :

$$x = \frac{lw}{1373s - 11'187}.$$

Assuming it to be intended to use a seven-strand steel suspending wire, then the cross-section of each strand must be :

$$\frac{x}{7}$$

The suspending wires are usually allowed a sag of about 2 per cent. of the span (value of s).

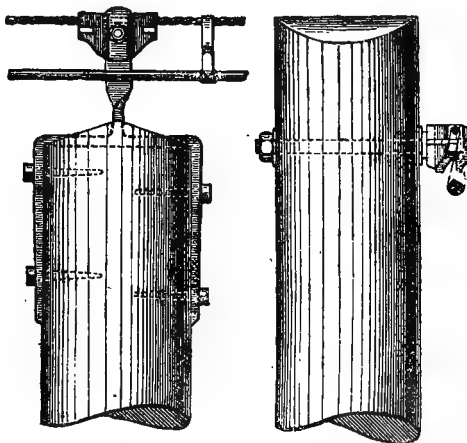

Fig. 303.

Fig. 304.

In England the suspending wires are usually attached to extra-strong double shackles, but a plan used to some extent upon the Continent, and illustrated by two methods of carrying it out in figs. 303 and 304, appears to have much in its favour. By this plan the steel suspending wire is simply clamped in position between the two sections of the supporting bracket.

A very good form of hanger is shown in fig. 305. It is practically a double hook of galvanised hoop-iron attached to the cable by means of galvanised binding wire.

Fig. 306 shows the suspender used for Patterson's aerial cables used very largely in the United States.

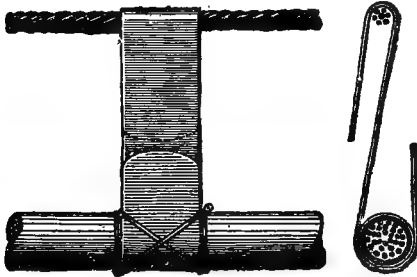

Fig. 305.



One of the best forms of suspender, however, and one that is becoming increasingly popular, is that shown by fig. 307. It consists of a short piece of

raw hide to which a hook for hanging to the suspending wire is attached. The loop is formed by simply passing the strip around the cable and threading the hook end through a slit in the other end. The weight of the cable itself supplies the grip.

The particular form shown is that made by Messrs. W. T. Glover & Co., in which the suspending hook is double. It can be applied to the suspending wire by

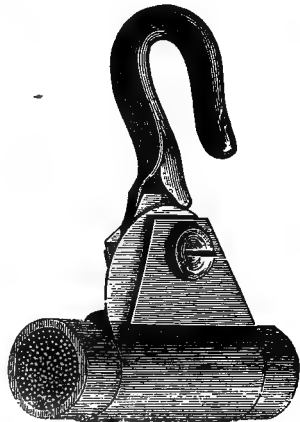

Fig. 305.

simply pressing the wire between the double hooks and then giving the latter a half-turn, so that the wire may

pass under the points of the hooks. The hooks are usually made of galvanised steel.

As the cable is pulled forward from one point of support to another the suspenders are one after another fastened to it at intervals of from 3 to 4 feet. As soon as one suspender, sliding on the suspending wire, arrives at a point of attachment, it is there unhooked by the lineman and suspended again on the other side, so that the cable during its forward motion carries its own supports and is not subjected to excessive strain.

The extent to which aerial cables are to be used will, of course, depend upon the conditions of each individual system; in some cases they may be applied with advantage to the whole system, while in other cases only a portion of the lines leaving the exchange would be in cables, while the remainder were ordinary open wires. This is, generally, the better plan, although the other

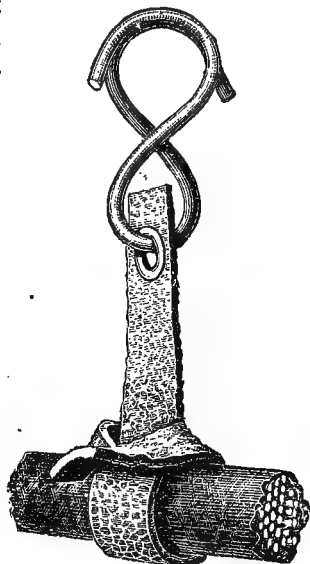

Fig. 307.

tends to reduce more effectually the necessity for constructing supporting frames of large size.

At the first point of junction, where a number of subscribers' wires branch off from the main line, the first of the cables is placed in connection with a certain number of aerial lines branching off from this point;

a second cable is treated in the same way at the second point of junction, and so on ; so that the main line in its whole extent is only burdened with a comparatively small number of open wires.

The junction of a cable with aerial lines is shown by fig. 308.

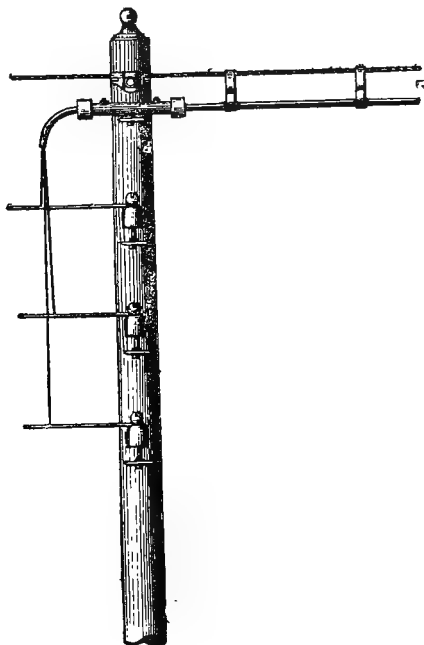

Fig. 308.

A good earth-connection, where single wires are used, is a matter of the utmost importance ; it not only contributes to the clear reproduction of speech, but also reduces the disturbing noises of the telephone. Careful attention to this detail is, therefore, a most important factor in a telephonic installation.

In towns having a universal domestic water-supply, water-pipes are most conveniently used for earth. The copper wire used for earth-connection is conducted to the nearest water-pipe—if possible, to an ascending main pipe—and carefully soldered to it. An excellent and most efficient earth-connection is obtained in this way, the whole network of pipes acting as conductor.

The use of gas-pipes for earth-connection is objectionable, because the pipes inside the houses are generally joined together by means of red or white lead, so that a considerable resistance may be introduced. In certain circumstances this might lead to very great inconvenience; for instance, if the earth for two telephones used in one house were obtained by means of the gas-pipes, it might easily be that the currents from one telephone, instead of going direct to earth, would pass through the earth-wire into the other telephone, so that there would be over-hearing between the two telephones.

Where there are no water-pipes available, a good separate earth-connection must be made. If there be a pump in use near at hand, that will furnish a very satisfactory "earth" if the wire be carefully soldered to it; but in all such connections great care must be taken to insure that the solder thoroughly adheres to the metal. Again, a plate of galvanised iron, or, better, copper, about 2 or 3 feet square, buried in ground that is always damp, is a plan of obtaining good "earth" often adopted.

On short circuits it is very important to secure the same sort of metal for earth-connection at both ends, otherwise the dissimilar metals of the earth-plates connected by a conductor furnish the conditions for a

current, which may become a source of serious disturbance in the circuit.

The maximum resistance that should generally be allowed for the earth is 10° , although in rocky districts it is sometimes difficult to get it as low as 100° .

CHAPTER XXIX.

WIRE FOR TELEPHONE AERIAL LINES.

THERE are many important considerations to be taken into account in determining the material to be used in the construction of telephone lines.

(*a.*) In the first place there is the need of mechanical strength. In a large system of overhead wires where many hundreds of wires run alongside and cross each other in all directions, it is very important that the wire shall be strong, in order to prevent breaking as much as possible, which is a source of the greatest inconvenience; for not only does the breaking of one wire most seriously interfere with the working by becoming entangled with other wires and so producing contacts, but, in the case of a more general breakdown, risk of personal injury is incurred, and the wires may also seriously impede the public traffic. Further, in the erection of over-house lines in towns, local conditions and, in many cases, personal prejudices have sometimes to be overcome by the erection of long spans which tax the strength of the wires to the utmost.

(*b.*) Durability is another important matter, both from the point of view of the working efficiency of the lines and from that of the cost of their maintenance.

(c.) Of course, the question of prime cost has often a more important bearing upon the decision as to the material to be used than any other; but this should certainly not be so where great interests are involved, as, for instance, in the case of a public telephone system.

(d.) The most important consideration, so far, at least, as very long circuits are concerned, is that of electrical efficiency. The electrical problem of long-distance telephony depends for its solution comparatively little upon the instruments used, while the electrical qualities of the circuit are all-important.

On short urban lines, where, if the wires are to be aerial they must be over-house and should have great tensile strength, steel wire naturally commends itself; and, for the sake of both economy and security, a wire of the smallest possible diameter, so as to be of the least possible weight, has generally been adopted. In some cases a stranded wire consisting of three No. 18 wires is employed; and a wire about No. 14 S.W.G., which will bear a stress of about 900 lbs., is much used. But the electrical resistance of this wire is high, amounting on an average to nearly 100 ohms per mile. This drawback, which would render such wire useless for long lines, is not generally important in the case of urban lines, where distances are limited. Nevertheless, inasmuch as the tendency of modern telephonic practice is to increase the facilities for extra-urban communication, the use of high resistance wire, even for short lines, is not to be commended.

The durability of iron and steel wires is secured by their being covered with a protective coating of zinc—the well-known process of “galvanising.” This protection of the wire is most important, because the lines frequently

pass directly over chimney-stacks or are erected in localities where the air is more or less charged with acid vapours, which soon destroy the steel. Even the zinc coating cannot entirely withstand this destructive influence. Under unfavourable conditions a steel wire may be entirely destroyed in two or three years. In specially exposed localities wire is employed which is protected by a serving of hemp or tape coated with an insulating substance, and this wire is stated to remain serviceable for many years. When the covering rots, however, it becomes very unsightly.

Originally the low tensile strength of copper wire prevented its use even where expense was no objection. Now, however, the manufacture has been so immensely improved that not only has its breaking weight been raised to 28 tons per square inch—a strength equal to that of mild steel—but there has been a corresponding improvement in its conductivity, which is almost equal to that of pure copper. Although even now its high price tends greatly to restrict its use, there is no doubt that copper is the material which must eventually become general for all circuits of any importance. Copper wire is, in fact, far superior in almost every respect to any other. Its strength has been already referred to. It is also less affected by impurities in the air—an important quality from the point of view of durability; for instance, in some localities, such as the neighbourhood of chemical works, where iron wire is destroyed in a few months, copper has been unaffected during eight or ten years' exposure.

In order to secure the same conductivity in any given length, the relative weights of copper and iron wire required are as 1 to $5\frac{1}{2}$, so that this leads to a

material decrease in the strain upon the poles and insulators.

A minor advantage is that the smaller wire required is much less conspicuous, and, therefore, much less of an eyesore, than the heavier wire, consequently giving rise to less opposition on the part of landowners, etc.

But the electrical properties of copper wire are even more valuable for telephony than its mechanical qualities. Its higher conductivity permits of the use of a much smaller gauge of wire, thus tending to a reduction of the electrostatic capacity. There is also the great gain which arises from the absence of electromagnetic inertia. It has been found¹ as the result of a large number of experiments made with an iron and a copper wire between London and Newcastle, that the increase of speed in electrical transmission through a copper wire over that in an iron wire is from 11·19 to 21·00 per cent., or a mean increase of 16·1 per cent.

Professor Hughes² has shown that with wires 1 mm. in diameter, taking the electro-magnetic inertia of soft Swedish iron wire as 100, that of copper is only 20. The difference, however, decreases with the increase of diameter, so that with 4-mm. wire (No. 8 S.W.G.) the relative inertias of iron and copper are 72 and 28, and with 10-mm. wire they are as 30 to 12. Variation of the strength of current has no effect whatever upon the relative positions of the metals.

Moreover, according to Professor Hughes, the effect is dependent upon both the molecular condition of the conductor and also upon its form; hard-drawn

¹ W. H. Preece, British Association at Aberdeen, 1885.

² Inaugural Address delivered before the Society of Telegraph Engineers, January 28, 1886.

iron, for instance, having a somewhat lower value than soft Swedish, and a stranded conductor made up of thin iron wires actually giving better results than a plain copper wire of the same cross-section. Apart from other objections, however, the mere consideration of a general use of stranded wire is almost precluded by the facts that such a wire gives a much more defined accumulating surface for snow than a circular wire; that with wires of equal resistance the electrostatic capacity of a stranded wire is from 5 to 10 per cent. higher, and that impurities being retained in the interstices of the strands materially reduces the durability of the wire.

Another and most important advantage of copper wire is the low electrostatic capacity which it has as compared with iron wire of similar resistance. Taking a copper wire and an iron wire of the same resistance, the former having a diameter of 79 mils and weighing 100 lbs. per mile, the latter would have a diameter of 207 mils and would weigh 593 lbs. per mile. The surface of the iron would thus be more than two-and-a-half times that of the copper. The *electrostatic capacity* of the copper wire would therefore be much lower. An aerial wire may be looked upon as one conducting plate of a condenser whose other plate is the earth, with the intervening air as the dielectric.

Several series of experiments have been made on telegraph and telephone wires, in various parts of the United Kingdom, with a view to the determination of the capacities of wires in actual use.

As regards the relative capacities of various gauges of wire, the theoretical condition that they should vary directly as the diameters is well borne out. For instance,

in tests over lengths of about 8 miles, when a copper wire of 224 mils diameter (800 lbs. per mile) gave a mean capacity of $\cdot 01743$ mf. with all other wires to earth, four 400 lbs. iron wire, in corresponding positions, varied from $\cdot 01347$ mf. to $\cdot 01426$ mf. The calculated capacity from the diameter (171 mils) would be $\cdot 0133$ mf.

The surrounding conditions, however, are found to lead to materially different results. This may be well illustrated by reference to a few tests of 800 lbs. copper wire made at various places. In the case just quoted, where the capacity was $\cdot 01743$ mf. per mile, the wire was in close proximity to other working wires, which could not be disconnected from earth. This, consequently, tended to raise the capacity of the wire under test. The height above the ground was about 24 ft. 6 in. and the whole section tested passed through well-wooded country. In another case tests were made where the wire was about 25 ft. 4 in. above the ground in a length of about 6 miles over a flat, clear country, and where it was twisted with the only other wire on the poles. With the companion wire to earth at both ends (that is, with practically the same conditions as in the former case) the capacity was $\cdot 0144$ mf. per mile; whereas, when the companion wire was disconnected at each end the capacity fell to $\cdot 0128$ mf. Again, in somewhat similar conditions with the wires at an average height of 24 ft. 9 in., the two wires, when their companion was to earth, gave $\cdot 0136$ and $\cdot 0138$ mf. per mile, respectively, in a length of about 13 miles, while, with the companion wire insulated, the capacities measured $\cdot 0117$ mf. and $\cdot 01198$ mf. per mile.

There is yet another advantage in the use of copper

wire for telephone lines, and that is, that the wires are much *less noisy* than those constructed with iron wire. Besides those noises which are the result either of mechanical vibration or of induction of one telephone or telegraph wire upon another, other noises occur which are the result of terrestrial causes. Every wire lies in the magnetic field of the earth, and when the wire in this field is thrown into a strong vibratory motion by strong winds, currents are induced in it. Such currents are especially observed in lines which have the direction from north to south, and thus by their vibrations cut the lines of force of the earth at right angles. These currents manifest themselves much more strongly in iron wire than in copper, because the iron wire behaves like a linear magnet and concentrates the lines of force.³

It is necessary that particular attention should be given to the fact that copper wire requires great care both in manufacture and in use. As regards manufacture the wire used by the British Post Office is subject to very strict inspection. It is carefully gauged and tested for ductility and tensile strength. To test its ductility the wire is wrapped in six turns round its own diameter, unwrapped and again wrapped in the same way; and it must do this without breaking. A piece is then gripped by two pairs of clamps fitted at a certain distance from each other, one being prevented from turning, and the other being slowly revolved until the wire breaks. The test for tensile strength is made by direct application of a stress slowly augmented until the wire breaks.

It is very desirable to note the distinction between *stress* and *strain*. The strain of a body is the proportion

³ "Weitlisbach die Technik des Ferrsprechens," Wien, 1886, p. 109.

of itself by which it lengthens. It is therefore a distortion. The stress is the load per square centimetre or per square inch which produces this strain. It is therefore a force. Stress is cause, strain is effect. The tensile strength of a wire is the stress it will bear before it breaks. It is frequently called the *breaking weight*. The elastic strength is the stress which produces a permanent set, and it indicates the *limit of elasticity*.

In the erection of copper wire also great care has to be exercised. Coils must not be carelessly thrown about, as they may be without harm in the case of iron wire. Flaws, indentations, scratches, kinks, and similar injuries act very much in the same way as diamond scratches on glass; the wire is likely to break at such places. Special drums, therefore, fitted with brakes, have been designed and made, so that the wire, being unwound under tension, may not get kinked.

The following is the specification for hard copper line-wire now issued by the Postal Telegraph authorities:—

NOTE.—In this Specification the term "piece" shall be understood to mean a single length of wire without joint or splice of any description either before being drawn or in the finished wire; a "coil" shall be held to be a piece of wire in the form of a coil; and a "parcel" shall be any quantity of manufactured wire presented for examination and testing at any one time. A "mil" is the one-thousandth part of an inch.

(1) The wire shall be drawn in continuous pieces of the respective weights and diameters given in the Table hereunto annexed, and every piece must be gauged for diameter in one or more places.

(2) The wire shall be perfectly cylindrical, uniform in quality, pliable, free from scale, inequalities, flaws, splits, and other defects, and shall be subject to the tests hereinafter provided for.

(3) Every piece may be tested for ductility and tensile strength, and 5 per cent. of the entire number of pieces may be cut and tested in any part. Pieces cut for this purpose shall not be brazed or otherwise jointed together, but each length shall be bound up into a separate coil.

(4) The wire shall be capable of being wrapped in six turns round wire of its own diameter; unwrapped, and again wrapped in six turns round wire of its own diameter in the same direction as the first wrapping, without breaking; and shall be also capable of bearing the number of twists set down in the Table, without breaking. The twist-test will be made as follows:—The wire will be gripped by two vices, one of which will be made to revolve at a speed not exceeding one revolution per second. The twists thus given to the wire will be reckoned by means of an ink-mark which forms a spiral on the wire during torsion, the full number of twists to be visible between the vices.

(5) Tests for tensile strength may be made with a lever or other machine which has the approval of the Officer appointed on behalf of the Postmaster-General to inspect the wire, and hereinafter called the Inspecting Officer, who shall be afforded all requisite facilities for proving the correctness of the machine.

(6) The electrical resistance of each test-piece shall be reduced according to its diameter, and shall be calculated for a temperature of 60° Fahr. Such test-piece shall measure not less than one-thirtieth ($\frac{1}{30}$) part of an English statute mile.

(7) If, after the examination of any parcel of wire, 5 per cent. of such parcel fail to meet all or any of the requirements of this Specification, and of the Table, the whole of such parcel shall be rejected, and on no account shall such parcel or any part thereof be again presented for examination and testing; and this stipulation shall be deemed to be, and shall be treated as, an essential condition of the contract.

(8) Each piece when approved by the Inspecting Officer shall be made into a coil and be separately bound; and in no case shall two or more pieces be linked or otherwise jointed together. The eye of the coil shall be not less than 18 inches nor more than 20 inches in diameter.

(9) Each coil of approved wire shall be weighed separately, and its weight (in English lbs. avoirdupois) stamped on a soft-copper label, which shall be provided by the Contractors, the label being firmly affixed to the inner part of the coil. The Contractors shall also provide the assistance necessary for properly affixing to each coil of approved wire, under the direction of the Inspecting Officer, a metallic seal which shall be provided by the Postmaster-General, the weight of this seal being deducted from the invoiced weight of

the wire when each delivery is made, or on completion of the order, as may be arranged.

(10) The approved wire shall be wrapped in canvas, and be delivered as required, securely packed in casks or cases.

TABLE REFERRED TO IN THE FOREGOING SPECIFICATION.

Weight per Statute Mile		Approximate equivalent Diameter.		Minimum Breaking Weight	Minimum No. of Twists.	Maximum Resistance per mile of Wire when hard at 60° F.	Minimum Weight of each piece (or coil) of Wire ¹
Standard	Range allowed	Standard	Range allowed				
lbs.	lbs.	mils	mils	lbs.	In 3 inches	ohms	lbs.
100	97½ 102½	79	78 80	330		30	9.10
150	146½ 153½	97	95½ 98	490	25	6.05	50
200	195 205	112	110½ 113¼	650	20	4.53	50
400	390 410	158	155½ 160½	1,250	25	2.27	80
600	585 615	194	191 196	1,800	20	1.484	80
800	780 820	224	220½ 226	2,400	15	1.113	80

¹ Except in the case of pieces cut for testing in accordance with paragraph 3 of the Specification.

A maximum weight of 112 lbs. for each coil is fixed for all sizes.

There can be but little doubt that the use of copper for telephone lines must eventually become almost universal. There are, however, several alloys of copper that have been very favourably received, especially where strong light wire is required. These alloys, which consist of copper with about 3 per cent. of tin, are designated (from the materials which in some form are used as a flux in the process of manufacture) silicium-bronze and phosphor-bronze. These admixtures, however, while producing wire that is of very considerably higher

breaking weight than is a corresponding size of copper, cause at the same time a great increase in resistance, so that they can be used advantageously only on short lines. For instance, a hard-drawn copper wire giving a resistance of 12.7^{ω} would have a breaking-weight of 260, where a similar gauge of silicium-bronze wire would give a resistance of 30.5^{ω} , and have a breaking weight of 331. The relative weights also would be respectively as 35 to 32.

CHAPTER XXX.

TELEPHONE CABLES.

THE employment of cables for telephonic communication becomes increasingly necessary, owing to the ever-increasing number of aerial lines in large towns. This necessity especially exists on the routes from a central office to the points where the wires begin to branch off in different directions. The number of wires led into a large exchange becomes so great that it is impossible to find accommodation for them as ordinary open wires.

There can be but little doubt that the telephone systems of all large cities will ultimately have to be installed with underground wires; but so far many telephone administrations—governmental, as well as commercial—have shrunk from facing the expense and the difficulties connected with such a system. A fairly good compromise between open aerial lines and underground lines is found in the adoption of *aerial cables*.

The difficulty which opposes itself to the employment of ordinary cables is the induction of each conductor upon the others, which enables a conversation carried on over one wire to be heard upon another. No really effective means of eliminating

this disturbing influence is known where a single wire is used for each circuit—it is apparently essential that two wires be used to secure a quiet circuit. Even with two wires it is necessary that they be so disposed that their plane does not run parallel to the plane of a second pair of wires.

The use of two wires, which has been systematically adopted by the British Post Office from the very first, has the further advantage (already referred to at p. 410) that it eliminates the effects of earth-currents.

The employment of two wires for one speaking circuit, however, so much increases the expense of the installation that many efforts have been made to devise some other means of getting rid of the effects of induction¹. In the first cables which were constructed by the British Post Office, in 1878, with this object, every individual insulated strand was surrounded by a coating of thin lead or tinfoil, which had been firmly pressed around it. This shielded arrangement, however, was only a partial solution of the difficulty, and, in order to make it effective, it has been found necessary that all the protecting coatings should be connected not only amongst themselves, but also to earth. Very many modifications of this device have since been introduced in different countries.

The efficacy of the lead covering is due, not to its acting as a shield between one wire and another, but to the fact that it constitutes a closed circuit for the currents surrounding the prime wire.

A serious objection to the plan is the increased capacity that results from bringing a continuous earth-connection so close to the conductors.

¹ W. H. Preece, "On some Physical Points connected with the Telephone," *Phil. Mag.*, April, 1878.

AERIAL CABLES.

The principal requirements for an aerial cable are:—

(a.) The smallest possible weight.

(b.) The highest possible relative tensile strength, so that it may withstand the stresses due to wind-pressure.

(c.) The use of such material for insulation as shall be able permanently to resist climatic influences, especially variations of temperature.

Aerial cables can be made with any number of conductors, but, as the number increases, the cables tend to become very cumbrous and difficult to handle.

UNDERGROUND CABLES.

The English telephone companies have not hitherto made use of underground wires to any extent, but the British Post Office adopts this method wherever possible, as much for economy as for efficiency.

The difficulties which this system introduces arise from induction, resistance, and capacity. These, however, like other difficulties, become less with increased knowledge, and there is now no lack of manufacturers who are well able to produce excellent underground cables for telephone purposes.

In England, where underground systems have existed since the first introduction of telegraphy in 1837, gutta-percha remains paramount as an insulating medium for subterranean and submarine purposes; but, when exposed to changes of temperature and moisture of the air, it rapidly deteriorates. For aerial purposes, therefore, indiarubber is more generally used, and is very durable. In America, where underground work was not viewed with favour until the public inconvenience arising from open work became unbearable, various other materials are being introduced, especially the

products of petroleum. Paraffin is used by some, but the most promising material is a heavy distillate of petroleum, such as is used in the Waring cable. Oils are used by others, and, when mixed with resin, they acquire a very high insulating efficiency. Cables in which the insulating medium is prepared dry paper are also now extensively used, and the extremely low capacity of a wood-beaded cable introduced in France by Fortin-Herrmann opens up fresh possibilities in underground telephone circuits. All these special cables are, almost without exception, lead-covered. It is interesting to note that the lead-covered cables buried in the streets of London in 1844 are identical in appearance and construction with many of those now being used. Lead is, however, very liable to accident when buried unprotected in the earth. Some soils act upon it chemically and destroy it. It should, therefore, always be protected. A good plan is to place a lead-covered cable in a trough, and to fill the trough with asphalte, pitch, or bitumen.

(a.)—*Post Office Aerial Cable.*

The form of aerial cable for double wires which has been found best suited to the needs of the British Post Office fairly represents the type of cable most useful under conditions such as we have to deal with in England.

The conductors are composed of three strands of tinned copper wire weighing together 20 lbs. per mile, and giving a mileage resistance of about 45^o. Each conductor is covered with two coats of compounded indiarubber, not vulcanised, bringing the diameter up to 129 mils, and the weight to 52 lbs.

per mile. The wires so treated are then tested carefully under water for insulation and electrification.² Its insulation must be about 200 megohms per mile after 24 hours' immersion in water. If approved, the wires are next taped with thin indiarubber-coated cotton tape laid on longitudinally, and covered with ozokerit. They are then twisted together in pairs, laid up in cables of the required number of wires, wormed with jute, and lapped with stout tape prepared with bituminous compound. After the whole core has received another coat of bituminous compound it is served with a coating of hemp thoroughly saturated with a well-boiled gas-tar compound and another coating of bituminous compound, over which is put the external covering of stout bituminous prepared tape and a coating of silicated compound. This forms a thoroughly reliable, durable, compact, and waterproof cable.

(b.)—*Post Office Underground Cable.*

The cable ordinarily used by the Post Office for subterranean purposes is uniformly made with four wires only, of which two, situated diagonally, are used

² *Electrification* is a phenomenon shown by insulating materials when a current of electricity is applied to them to obtain their insulation resistance. It is due to the leakage current polarising the dielectric. If the current be kept on the insulation apparently improves—rapidly at first, then more slowly—the leakage current diminishes in strength; in other words, the resistance apparently gradually increases, owing to the formation of an opposing electro-motive force in the medium, which thus acts as a liquid electrolyte. As this effect varies with time, it is usual to take a test-reading for insulation after *one minute's electrification*. The rate of fall due to electrification is a good test of the soundness of the insulating material. It varies very much with the quality of the material, and with temperature, being more marked at low temperatures. Unsteady electrification is a sign of an incipient fault in the insulation, and slow electrification, when not due to defective insulation, is an indication of good material.

for each of two circuits. The copper conductor of each wire weighs 40 lbs. per mile, and is covered with a solid coating of best gutta-percha, weighing 50 lbs. per mile. The insulation is specified to range between 200 and 1,000 megohms per mile, and to have in water an inductive capacity of '29 mf. per mile. Four of these wires are laid up with a lay of 7 inches, having a centre and worming of tanned jute sufficient to make the cable cylindrical. The cable is then served with a single covering of specially prepared grey linen tape.

(c.)—*The British Insulated Wire Company's "Paper" Cables.*

The British Insulated Wire Company manufacture insulated conductors under the patents of the Norwich Insulated Wire Company of New York, using as a basis for insulation prepared material, which is generally called "paper." This is treated in such a way as to give it great strength mechanically, high insulation electrically and chemically great durability. The construction of the cable is a mechanical one, being built up layer upon layer with the prepared insulation. The result is that the insulation does not depend simply upon one layer, but has the benefit of solidity, and at the same time of numerous separate thicknesses of the material, which help one another. Both for mechanical and electrical reasons such cables are generally lead-sheathed over the insulation, not necessarily as a waterproofing, but as a mechanical protection which will defend the core from damage. Of course, the lead sheath does perform the function of a waterproof covering, but lengths of core tested in water at different temperatures and pressures have shown a remarkable

absence of any absorption of moisture. A further advantage of the lead sheathing is that it tends to consolidate the insulation when the cable is being wound off or on to a drum, or is being drawn round the corners in a pipe-line or conduit.

The finished cables show a high insulation. It has been found that a thickness of 1 millimetre gives way with an electromotive force of 10,000 volts, thus showing that the material is quite as good as india-rubber in its ultimate strength to resist disruptive discharges.

It is usual to tape or braid over the lead sheathing, such covering being treated with preservative compound. Apart from the protection that this gives against chemical action upon the lead, it is almost impossible without it to draw such a cable through an iron pipe. Even when braided the drawing-in is much facilitated by the use of French chalk.

The cables are tested after twenty-four hours' immersion in water at 60° Fahr. Four-wire cable of the American Conference Standard³ Pattern shows an insulation of about 10,000 megohms per mile and a capacity of only .08 microfarad. For long-distance work a four-pair cable is made which has an insulation of 2,000 megohms per mile and for Nos. 10, 12, and 14 copper covered to No. 1, a capacity per mile of .12 mf., .1 mf., and .09 mf. respectively.

³ The "Conference" standard was arrived at by a conference of representatives of the principal telephone companies of the United States, which is convened annually for the discussion of telephonic matters. The dimensions for twisted pairs are :—

Diameter of conductor, .035 inch.

Outside diameter of insulation, .125 inch.

Length of twist, 2 $\frac{3}{4}$ inches to 3 $\frac{1}{2}$ inches.

(d.)—The Patterson Cables.

These cables are very largely used in America. They are composed of groups of copper conductors, each of which is suitably coated with a dry insulating material—either paper or cotton—and drawn into a lead pipe.

Originally Patterson used cotton or jute saturated with paraffin as the covering, and, after drawing-in, the lead tube was filled with melted paraffin aerated with dry gas.

The insulation of this material is very high, and it will not vary as long as the lead covering remains uninjured. More important still, although as is well known the inductive capacity of paraffin is very low, it is said to be lowered by at least 15 per cent. by the aëration. In fact, by laying the wires loosely together and forcing the prepared paraffin between them a dielectric was obtained which, consisting of paraffin and minute bubbles of gas, possessed a much lower inductive capacity than if the whole space were filled with cotton, gutta-percha, or other insulator.

Even in these early cables the value of low capacity was well recognised; but increasing experience proves this to be a matter of supreme importance, and hence has arisen the radical modification of principle implied in Patterson's "dry core" cables, in which the separating material is not interpenetrated with insulating filling. As air is one of the best of dielectrics, it is evident that the more air and the less of any other substance that intervenes between the wires, the lower will be the capacity—hence the advantage of "dry core." There is however, a corresponding risk, for, should the lead

covering become defective by any means, and so permit moisture to enter, the insulation is at once destroyed. The entrance of moisture was almost entirely precluded by the paraffin filling—at worst it could not penetrate far. A consideration of this difficulty led to the following conclusion. These cables being usually drawn into pipes cannot ordinarily be handled except at the manholes or joint-boxes, so that if a fault occurs midway, of whatever form the cable is, it must be drawn out. Speaking generally, however, faults are most likely to arise at the manholes where work is carried on; and, further, when the lead coating has been thoroughly tested under hydraulic or pneumatic pressure before use, the principal danger is in the jointing. The splicing of two lengths of a cable with a good number of wires takes a considerable time, and this may facilitate the introduction of moisture, and so lead to the breakdown of the cable. To provide against this the Western Electric Company fill their “dry core” cables with aerated paraffin at the ends for a few feet.⁴ Thus, while the advantage of low capacity is secured by the core being mostly “dry,” the filling at the ends prevents the access of moisture when splicing, and renders it comparatively easy to make repairs just at the points where damage is likely to arise.

The material used for the covering of “dry core” conductors is now a specially-made paper, which is also prepared in a particular way, in order to form air-spaces when the paper strip is wound on the wire.⁵ The central portion of the tape is corrugated transversely by being run between cogged wheels as it is being wound on the bobbins, and when the paper is wound spirally

⁴ British Patent Specification 2,654 (February, 1890).

⁵ British Patent Specification 6,569 (April, 1892).

over the wire this central portion, softened by the corrugations, becomes puckered, and forms a spiral ridge. Two layers of 60-lb. paper in $\frac{5}{8}$ -inch tape will cover a 40-mil wire to a diameter of 125 mils.

The average capacity of such wires when made up in a 50-pair cable having an outside diameter of $1\frac{1}{16}$ inch is .07 mf. per mile.

The tape may be perforated instead of being corrugated in the centre, but the corrugation is preferred.

The Western Electric Company make a very compact and efficient form of tablet upon which their cables may be terminated. It is shown by fig. 309.

(e.)—*Walter T. Glover & Co.'s Cables.*

Until somewhat recently the form of telephone cables manufactured by this firm was for single-wire working, and constructed in a manner to lessen and avoid "cross-talk." These anti-induction cables, as they were termed, consisted of a number of insulated wires formed into cables of the requisite size. Each wire was of No. 18 (48 mils) tinned copper, insulated with several thicknesses of pure rubber strip, and protected with prepared tape, each taped wire being subsequently served with insulating and protecting compounds. A certain number of these wires were coated with lead-foil, and placed in definite positions

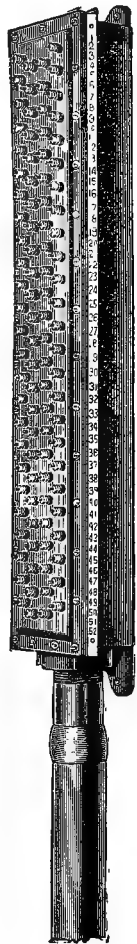

Fig. 309.

in the several layers. The position of these lead-foiled wires being systematic, the definite number or exact position of a wire was known. These lead-foiled wires, in consequence of the several layers of the cable being in opposite directions, were in contact, so that in each cable all the lead-foil coatings were in electric connection. The multiple cable thus formed was lapped with wide lead-foil, which was therefore in contact with all the lead-foil coatings in the cable. This outer coating of foil being connected to earth at the end and at any intermediate points, it will be seen that an earth-connection to intercept induced currents was

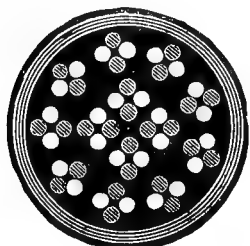

Fig. 310.

present throughout the whole of the cable. The cable was externally protected with a special double braiding served with a preservative compound possessing weather-resisting qualities. This form of external protection has been found to withstand most successfully the trying English

climate, and it is stated that in towns where these cables have been erected there is no apparent deterioration after many years of exposure.

To meet the demand for a cable to work a number of metallic circuits a new form was designed, which has been very largely adopted. This form, shown in figure 310, is termed the "Magpie," and consists of wires laid up in fours or "double pairs." The wires are insulated in a similar manner to those in the anti-induction type, but a portion are protected with a white felt tape, instead of the black served tape. The fours are made up of two white and two black, placed

alternately, so that the two of the same colour are opposite to each other, and form a pair for a metallic circuit. In the 52-wire cable, which is the favourite type, the centre consists of *four* sets of fours surrounded by *nine* sets of fours. A distinction is made in each layer by substituting a "black" wire for one of the white ones. This makes in one set one pair "white and black," and the other, as usual, "black and black." This set forms the "key" to the numbering; and the first pair, No. 0, begins with the inner white and black pair. The similar pair in the outside layer is No. 8, the last pair being No. 25. The white pairs have even numbers and the black pairs uneven numbers.

The object in making the first pair No. 0 is that when a cable is required with only 50 wires, the No. 0 pair may be omitted, its place being taken by a "dummy" pair, so leaving the numbering of the rest of the wires unaltered. The numbering is always taken to the right hand of this "key" pair in reference to a given direction. These cables have been made with 104 wires, or 52 pairs, by putting on a third layer, which would also have a "key" set of fours, and, of course, any required number could be made up. The cable is protected with white felt tape, then double lead-foiled, lapped with a specially-served tape, and finally braided and served with compound as in the cables previously described.

In all the cables manufactured by this firm for telephonic purposes this special system of numbering is so carried out that any wire can be identified externally in any part of the cable without "pricking" or cutting—an arrangement which is of very great advantage.

Fig. 311 shows a modification of this cable, in which the wires are in simple pairs.

A later form of cable which is at the present time in great request was designed to meet cases where, although required in the first instance to be worked as single-wire circuits, the cable would ultimately be applied to metallic-circuit working. These were conditions which the "anti-induction" and "Magpie" forms could only fulfil separately. In the improved form of cable this combination has been so effectually secured that cables (of the form shown by a 52-wire cable in figs. 312 and 313)

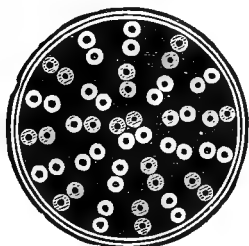

Fig. 311.

on single-wire circuits with less disturbance from "cross-talk" than the old anti-induction form, while they are also suitable for use as pairs for metallic circuits.

These cables are made up of 48-mils tinned wire insulated with pure rubber as in the previous cases, but protected with a different quality of tape. This is a special form of tape, rubber-proofed on *one* side only. By applying this tape over the insulated wire, with either side of the tape outwards, two types of protected wire are obtained, one black, the other grey. The cable is then built-up with pairs alternately grey and black. In the 52-wire cable the centre is formed of two grey wires and two black, which are coated over all with lead-foil. The second layer consists of ten wires in alternate pairs of grey and black; but the first grey wire in this and all subsequent layers is, for two reasons, coated with lead-foil; and over the second layer also is a

coating of lead-foil. The third layer consists of 16 wires in pairs, and the fourth layer of 22 wires ; the two layers, as before, being separated by lead-foil. Over all are lapped two layers in opposite directions of lead-foil of a quality specially manufactured for these cables. The whole is then doubly braided and doubly served as in previous cables.

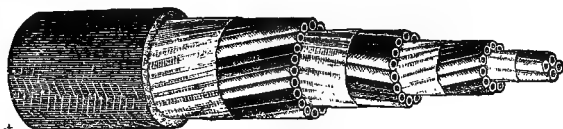

Fig. 312.

The single lead-foiled wire serves, in the first place, to distinguish it as the No. 1, or the first wire in each layer, the second wire being the single grey next to it. The numbering of the wires from 1 to 52, or 1 to 100, therefore, becomes easy. The lead-foiled wire also serves to establish electrical connection throughout the whole of its length with the lead-foil coatings above and below it, so that in this form of cable a very large metallic surface permeates the whole of the cable, and as this is placed to earth at the ends of the cable and at intermediate points, there is an earth-connection of very large surface extending right through the cable, which prevents any "cross talk" being heard.

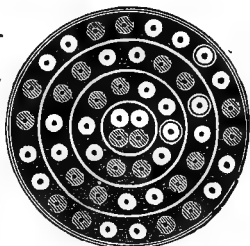

Fig. 313.

In a 52-wire cable the resistance of the lead-foil is about 23·3^o per mile, and in a 100-wire cable it is about 12^o per mile ; consequently, if in a mile of 100-wire

cable the external lead-foil were earthed at every $\frac{1}{16}$ the maximum resistance from any point to earth would be only 0.37^m plus the actual earth resistance—representing a conductivity sufficient to carry off any induced currents or external disturbing influences, and to prevent any interference when working single-wire circuits.

For working metallic circuits there are two methods: the first is by operating with pairs of two adjacent wires, which is stated to work satisfactorily without induction or "cross-talk," or a second method can be adopted by taking in each layer the two wires which are diametrically opposite to one another. Thus in the second layer of 10 wires, the pairs would be Nos. 1 and 6, 2 and 7, 3 and 8, 4 and 9, 5 and 10. These wires, being exactly opposite, equi-distant, and making a complete twist once in about 6 to 8 inches, will be found to act as ordinary pairs, and to be free from induction or "cross-talk."

This form of cable weighs about 2 lbs. to the yard for the 52-wire, and a little over 4 lbs. to the yard for the 100-wire. It is remarkably flexible and easy to handle, and can be run up over houses with the greatest facility in very long lengths, half a mile and upwards. Its insulation is high and good, and its lasting properties, as shown by the experience of similar externally protected cables, very considerable.

For the most part these cables are found to give an insulation resistance of about 500 megohms at 60° Fahr. and a capacity of .27 mf. per mile. The conductors are invariably of tinned copper with a standard conductivity of about 98 per cent.

Self-supporting cables of two or three wires have been produced by this firm by the use of a central steel or

phosphor-bronze wire. This is insulated in the usual way, so as to be used as a conductor.

(f.)—*Fowler-Waring Cables.*

These are of two classes, the "Waring" and the "Dry Core." In the former the copper conductors are cotton-covered, then laid together in twisted pairs, stranded and braided. The cable thus formed is saturated in a heavy distillation of petroleum, and when completely permeated it is encased in lead, the tube being formed directly round the cable under great hydraulic pressure. The advantages claimed for this insulating substance are that it is not liable to disintegration or deterioration; that it is an exceedingly refractory substance—the surrounding or internal temperature may be raised to the point of fusing the leaden casing of the cable, or the raising of the temperature of the conductor to a white heat, without injuring it or affecting the insulation resistance; and that its low capacity, as compared with gutta-percha, rubber, and many of the other insulators, renders it very suitable for the purposes of telephony.

The demand, however, for a lower capacity than can be attained with the Waring core, has led to the introduction of various types of "dry-core" cables, and that which is manufactured by the Fowler-Waring Company resembles the cable made by Mr. Brooks and used by the Bell Telephone Company of Philadelphia. It is illustrated by fig. 314. In this cable the separate conductors are surrounded by a loose wrapping

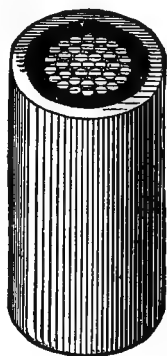

Fig. 314.

of specially-prepared fibre, which is practically non-hygroscopic and possesses great strength, together with chemical purity and high insulation resistance. The wires

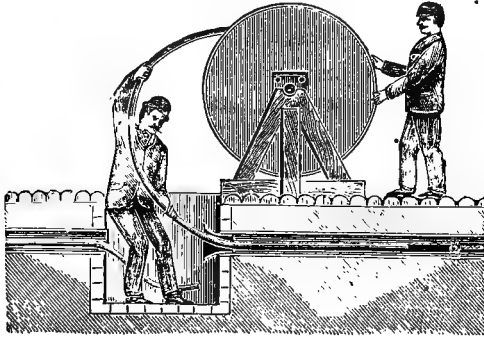

Fig. 315.

are laid together in twisted pairs, stranded, braided, and lead-covered, as in the Waring cable. Extreme care

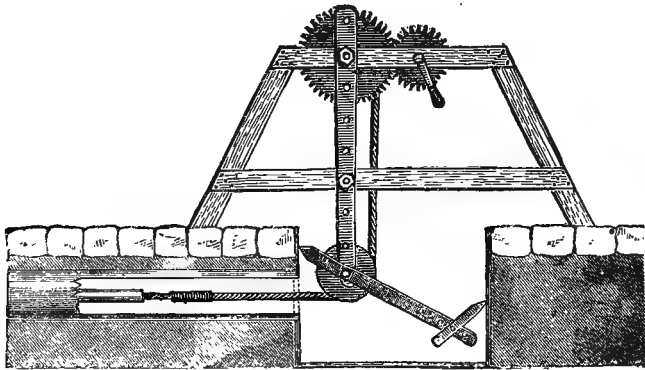

Fig. 316.

and considerable experience are essential in the laying and jointing of these dry-core cables; but, given these, it is possible to attain a very high efficiency.

The following comparative results are from three telephone cables, each composed of 100 conductors in twisted pairs and of approximately the same total external diameter; the conductor resistance in each case was 35·53^o per mile :—(1) Fowler-Waring "Dry Core," '07 mf. per mile; (2) "Waring Core," '16 mf. per mile; (3) "Gutta-percha-covered," '30 mf. per mile.

Fig. 315 shows a method of feeding cable into a man-hole, and fig. 316 a convenient form of windlass for drawing in.

(g.)—*Felten & Guilleaume Cables.*

Cables of the ordinary type, as manufactured by Messrs. Felten & Guilleaume, have the conductors insulated with impregnated fibre, over which is placed a coating of tinfoil. Made up with the strands are one or more bare copper or steel wires, which are therefore throughout their length in permanent connection with the metallic coatings of tinfoil with which each strand is covered, and are then at each end of the cable connected to earth. Thus the metallic coatings of all the strands represent one uninterrupted line of good conductivity, the effect of which, when it is connected to earth at both ends, is to weaken the inductive effects of one strand upon another.

Such cables are necessarily lead-covered, but otherwise their construction is very varied. For aerial use it is generally considered advisable to serve the lead covering with a layer of tape or a twine braiding; in either case the covering is impregnated with zinc-white.

Such a cable is shown by fig. 317, which represents a 52 single-conductor cable having four earth-wires and a

double lead covering. The conductors are No. 19 S. W. G., the four earth-wires about No. 17, and the complete cable weighs about 5'94 tons per mile.

For underground lines the taped covering is usually asphalted, and may be sheathed with galvanised iron ribbon or with either round or flat galvanised iron wire. The advantages of flat wire sheathing are that it takes up less space and is very smooth, so that it is said to be suitable for drawing into iron pipes. The German Telegraph Administration has made use of such cables to a considerable extent ; the arrangement of the conductors adopted by them being as shown by fig. 318. There are

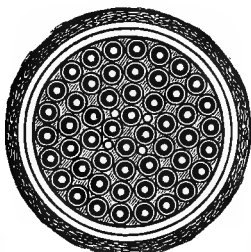

Fig. 317.

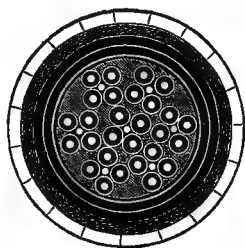

Fig. 318.

seven groups of four twisted conductors, insulated and tinfoiled, with an earth-wire in the centre of each group. This arrangement provides for the use of a mixed system of single-wire and metallic circuits, the diagonals of a group being used for the latter. If the system were entirely of metallic circuits, the tinfoil and the earth-wires would, of course, not be needed. The weight of this cable, with No. 19 conductors and flat wire sheathing is about 6'34 tons per mile. It is usually considered advisable to have soft double lead covering for underground cables, and for overhead purposes to have a single thicker tube hardened by an admixture of tin.

The connection of the cables with one another and with the ordinary open wires is a matter that calls for the most careful attention, as the admission of moisture will practically ruin a fibre-insulated cable, hence Messrs. Felten & Guilleaume recommend the use of a short section of indiarubber-insulated cable, otherwise arranged in the same way as the cable to be jointed. The joint between the rubber and the fibre cable is enclosed in a hermetically sealed case, and the other end of the short rubber-covered section is connected to the open wires.

For "paper" cables, the peculiar feature of the

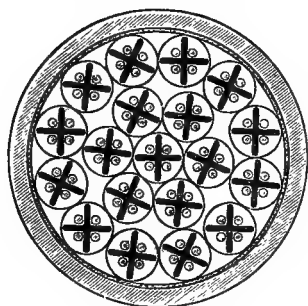

Fig. 319.

Full size.

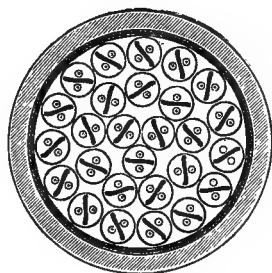

Fig. 320.

manufacture by this firm is the use of simple longitudinal bands for separating the conductors. Preferably, two or four wires are spirally twisted in a long lay with the paper diaphragm between them, thus forming groups of two or four conductors, and any desired number of such groups may be formed into a cable. If the group is of four conductors, the section of the diaphragm forms a cross (fig. 319); if of two, it is a simple strip (fig. 320). Each group of two or four conductors is, after twisting, served with a paper wrapping which practically forms a paper tube divided into two or four cells, each of which

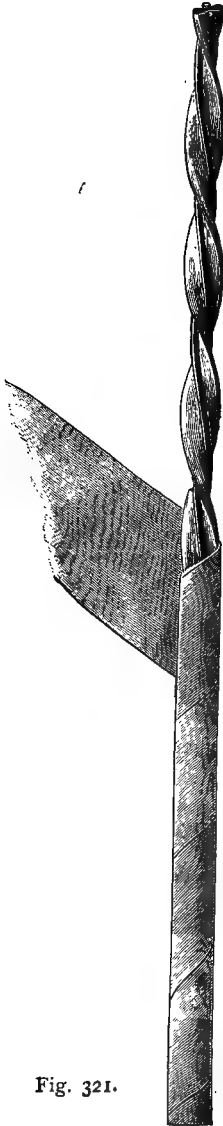

Fig. 321.

accommodates a copper conducting wire, with plenty of air-space. Two wires so laid together and wrapped are shown by fig. 321. The groups thus finished are laid up together to form the cable, which is served with a good wrapping of paper tape, after which the lead cover is put on, with or without the outside covering of tape or iron sheathing as described above when speaking of the older forms of telephone cables.

The paper used in these cables may be either impregnated or simply dried to remove all moisture; in the latter case, of course, the lowest capacity is obtained. The capacity with copper conductors No. 20 S.W.G., is '113 mf. per mile as a maximum for impregnated cables, or '08 for dried paper. These figures being given as a maximum are said to be considerably above those actually obtained.

Fig. 320 is a section of a cable containing twenty-seven pairs of No. 21 S. W. G copper wires enclosed in a lead tube. Fig. 319 shows a cable containing nineteen groups of four conductors, No. 19 S.W.G.

The same system is available for

submarine cables for long-distance telephony, but the construction in this case is necessarily somewhat modified: for instance, in a cable with four conductors (No. 13 S. W. G.), the conducting wires, with their cross-shaped diaphragm, are formed in a group, and the group is wrapped with paper as above described. This is enclosed in a lead tube, after which a double coating of gutta-percha is applied. The sheathing, instead of being of round wires, is formed of galvanised wires so shaped that they lock into each other, forming an incompressible and impenetrable pipe-like envelope, which effectually protects the cable core from outside pressure. Longitudinal and transverse sections are shown by figs. 322 and 323. We are not aware that this cable has been afforded an actual trial for submarine work, but it may be remarked that this firm

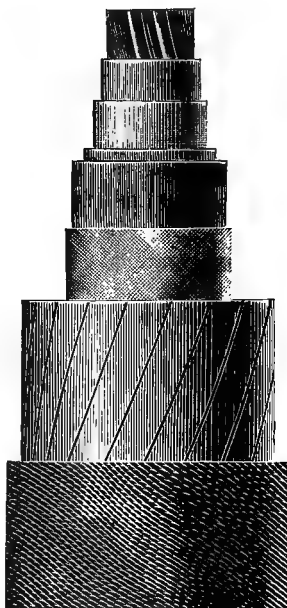

Fig. 322.



Fig. 323.

manufactured the (gutta-percha insulated) cable thirty miles in length which has been in use between Monte

Video and Buenos Ayres since 1889, and represents the longest submarine section in any telephone circuit yet laid.

(h.)—*Fortin-Herrmann "Beaded" Cable.*

Early in 1884¹ M. Fortin-Herrmann conceived the idea of encasing the several conductors of a telephone cable in short tubes of prepared wood in the nature of beads. By this means the conductors are well separated at the



Fig. 324.

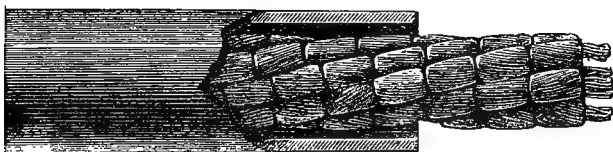

Fig. 325.

same time that they are not subject to the same static effect that follows by the use of the older dielectrics.

Fortin-Herrmann's practice is to make cables containing from one to fourteen conductors enclosed in a lead tube.

Figs. 324 and 325 show respectively two and six wire cables of this form. The manufacture, which is carried out by means of ingenious machinery devised by the inventor, is very simple, and the cables are consequently quite economical.

As in the case of all cables which aim at "air" insulation, great care is needed to prevent the ingress of

moisture—moist air is, of course, almost as bad as actual damp, as its moisture is sure to condense. Hence the cables must be carefully sealed at the ends. When, however, damp makes its way in, a current of dry air passed through the tube from end to end is said to afford a very simple and effective cure—assuming, of course, that ingress of moisture is not gained through a flaw in the lead tube.

The following Table gives the specification limits of the essential electrical qualities for several standard sizes, from which it will be seen that the capacity is remarkably low, and compares favourably with that of almost any other form of cable.

Conductors.		Resistance per Kilometre.	Capacity. per Kilometre.	Insulation per Kilometre.
Number.	Diameter of each Strand.			
	Millimetres.	Ohms.	Microfds.	Megohms.
1	·5	13·5	·05	400
2	·5	13·5	·06	200
2	·5	30·0	·05	200
4	·7	7·5	·06	200
6	·7	7·5	·06	200
6	·5	13·5	·06	400
14	·5	13·5	·06	200
14	·5	30·0	·06	200

The number of strands in each conductor is seven, except in the case of the third and the last types, which each have only three-strand conductors.

It is stated that the insulation generally reaches 2,000 to 5,000 megohms, and is constant at the value reached.

These cables have been very favourably received by the French Administration, and are used to a considerable extent in the Paris sewers.

CHAPTER XXXI.

ON THE LIMITING DISTANCE OF SPEECH.

THE distance to which speaking by telephone is possible depends upon the law that has been shown by Lord Kelvin to determine the speed with which currents can be transmitted through a submarine cable.

Every circuit has a *time-constant*, which is dependent upon the conditions of the circuit. It is the time which the current takes to rise from zero to its maximum and to fall again to zero. Now, the highest speed in telegraphy which has yet been attained requires that the time-constant for the line shall not exceed $\frac{1}{250}$ of a second; but for ordinary telephone speaking it would appear that to ensure clear articulation the time-constant of the line must not exceed $\frac{1}{8000}$ of a second. This indicates that the limit of telephonic communication is likely to remain far below the telegraphic limit under like conditions; but it is of course possible that the telephonic requirements may be more easily satisfied, inasmuch as the actual limit is in both cases ultimately determined by the instruments rather than by the lines.

The limiting conditions of telephonic speech are the

resistance, the capacity, and the electro-magnetic inertia of the circuit. Resistance alone has almost no effect upon the time-constant. In conjunction with capacity however, the *retardance* in a circuit varies directly as both the resistance (R) and the capacity (K); the effect is therefore expressed by $K R$. The retardance due to electro-magnetic inertia, however, varies directly as the amount of electro-magnetic inertia (L) present, but inversely as the resistance (R), and may therefore be expressed by $\frac{L}{R}$. The whole retardance of a circuit

therefore varies directly as $\frac{L}{R} + K R$, and the speaking-efficiency may be said to vary inversely as the retardance.

If now in the above quantity, L be made equal to 0, then the speaking efficiency will simply vary inversely as $K R$. Of course, it can only be in non-magnetic metals that there is no electro-magnetic inertia, and hence the necessity that all long telephone circuits should be of such metal. Its low resistance as compared with its alloys makes *copper* by far the most suitable of the metals for telephone circuits, and it is accordingly universally used for long lines and is increasingly employed upon all telephone circuits.

Lord Kelvin's law for the time-constant of a circuit shows that the time varies directly as the resistance (r) per unit of conductor (mile or kilometre), as the capacity (k) per unit length, and as the square of the length (l) in terms of the unit. It is expressed by the formula

$$a = Bkr l^2$$

in which B represents a constant which depends principally on the units used.

As already explained, the speaking efficiency (s) of a copper-wire telephone line varies inversely as the $K R$, so that it may be expressed thus :

$$S = \frac{\text{constant}}{K R}, \text{ or } K R = \text{constant} / S = (\text{say}) A \dots\dots(1)$$

And this is clearly only another form of Kelvin's law, for $K = .lk$ and $R = lr$, and therefore

$$A = krl^2 \dots\dots\dots (2)$$

The values of A which determine the limiting distance of speech for different conditions have been found by experiment to be as follows :—

Copper (open-wire)	15,000
Cables and underground	12,000
Iron (open-wire)	10,000

By equation (1) therefore can be determined whether speech is possible over a circuit of known capacity and resistance ; and from equation (2) can be calculated the extreme distance over which, so far as the line is concerned, it is possible to transmit speech under specified conditions, for

$$l = \sqrt{A/kr} \dots\dots\dots (3)$$

For instance, the limit with copper wire weighing 150 lbs. per mile (No. 12½ S.W.G.), and having a resistance of 6·05 ω , and a capacity of ·01 microfarad per mile, will be

$$l = \sqrt{\frac{15,000}{\cdot 01 \times 6\cdot 05}} = \text{about } 498 \text{ miles,}$$

which is the extreme distance at which speech would be possible on such a wire.

Of course the constants which determine the distances at which speech is easy and practical are less than these. They may be taken to be as shown below :

Copper (overhead)	10,000
Cables and underground	8,000
Iron (overhead)	5,000

The values of l , which result from inserting these values of A in equation (3) will give distances over which speech will be practical.

The difference in the values of A for copper and iron is due to the presence of the self-induction, or electromagnetic inertia of the latter ; that is to say, the electromagnetic inertia can, for practical purposes, be allowed for by a reduction in the value of A . The difference between copper overground and copper underground is to be accounted for by the facility for discharge to earth of the static charge offered by the former through leakage over the insulators at the points of support, whereas in guttapercha-covered wire its only exit is at the ends. It has been suggested, however, that there is no difficulty in working telephones through underground wires if they be properly designed, and due regard be given to the conditions that have been explained.

There is a very important consequence of Lord Kelvin's law, and that is that the speed of working between the two ends of a circuit that is principally cable or underground is exactly the same when a metallic circuit is used without earth as when a single wire of similar character with earth at both ends is employed. It results from this that the limiting distance of speech is not reduced by the use of such a metallic

circuit. This is owing to the fact that though in the latter case the resistance is doubled, the effective capacity is halved, leaving the resultant $K R$ the same. The following graphic investigation of this fact is due to Mr. H. R. Kempe.¹

If b, d (fig. 326) be a cable, with its further end d insulated and its nearer end b connected through a battery E to earth, then, if $a b$ represents the electromotive force of the battery the charge in the cable

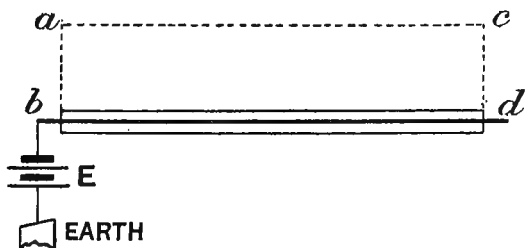

Fig. 326.

may be represented by $a b d c$. Let this be equal to 4.

If now, the end d of the cable be put to earth (fig. 327), then (assuming that the resistance of the battery is negligible) the charge in the cable will be represented by $a b d$, which will be equal to 2. This represents the effective capacity in ordinary working conditions with a single wire.

Now, instead of connecting the second pole of the battery to earth, let it be connected to the further end of a second cable (fig. 328). This is clearly analogous to the

¹ "Electrical Review," vol. xxx. p. 33.

case of two capacities joined in "cascade," so that the capacity of $b d$ is reduced to half that in the conditions represented by fig. 326. Further, it is equivalent to the conditions shown in fig. 327 and also in fig. 329, where $b d$

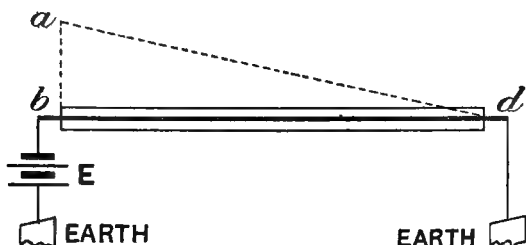

Fig. 327.

is a cable with such an extra thickness of dielectric that its capacity is half that of the cable in fig. 326. Therefore the charge (represented by $e b d f$ in figs. 328 and 329) will be equal to 2.

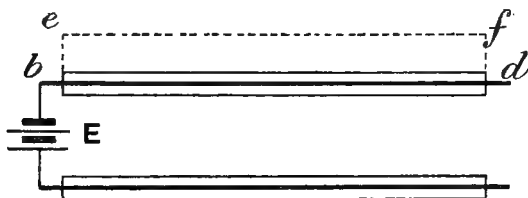

Fig. 328.

Take now the case shown by fig. 330, where the ends d of the cables are joined together. The conditions now are equivalent to those shown by fig. 331, in which the charge held is represented by $e b d$, which is equal

to 1. In fig. 330 are represented the conditions of a metallic circuit, and the charge held, that is practically

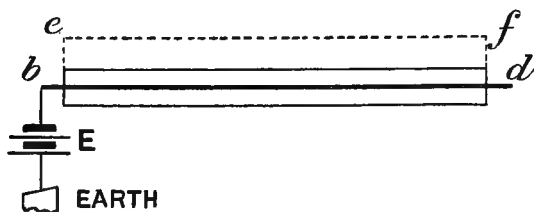

Fig. 329.

the "effective capacity," is shown to be equal to 1. But the effective capacity with a similar single wire with

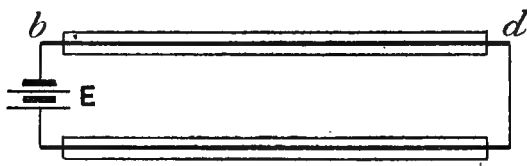

Fig. 330.

earth at both ends (fig. 327) was shown to be 2. Thus the "κ" of a metallic loop is only half that of a single

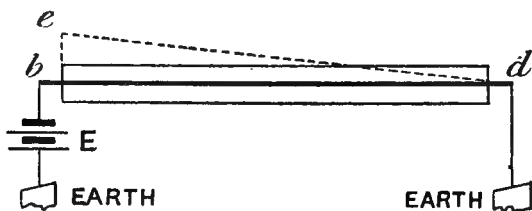

Fig. 331.

wire circuit between the same points. As already noted, the conductor resistance of the metallic loop (fig. 330) is

twice that of the single wire (fig. 327), so that the $K R$ in the two cases is respectively—

$$K \times 2 R \text{ and } 2 K \times R$$

of which the products are equal.

It should, however, be here remarked that on open wires the law of half the capacity for looped wires does not strictly apply.

Beyond the qualifying conditions which determine the limit of speech, that have been already explained, there is another which in some circumstances may have a very important effect, and that is the mutual induction of the two wires of a metallic circuit upon each other.

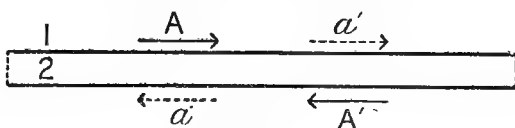

Fig. 332.

From an inspection of fig. 332, it will be clear that the current a induced in wire 2 by the current A passing in line 1 is in the same direction as the primary current A' in 2, and that equally the current a' induced in line 1 by current A' , also assists the current A . Thus the mutual action of the two wires tends to improve the speaking. This effect of induction tends to neutralise the effect of capacity. They are opposed to each other. Electro-magnetic induction becomes negative capacity. The unexpected clearness of communication upon the telephone lines between London and Paris is to be attributed largely to this effect.

The London-Paris telephone circuit takes a very high place in long-distance telephony, and is of special interest for the present subject from the successful work-

ing through a considerable length of submarine cable. The circuit is made up as follows :—

	Distance.	Resistance (each wire).	Calculated Capacity (each wire).
London to St. Margaret's Bay	miles. 84·5	ohms. 183	microfarads. 1·32
St. Margaret's Bay to Sangatte (cable) ...	23·0	143	5·52
Sangatte to Paris ...	199·0	294	3·33
Paris, underground ...	4·8	70	·43
Totals... ..	311·3	690	10·60

This shows the total *K R* of the loop to be 7,314 ($5·3 \times 1,380$), which is well within the speaking limit. Telephonic communication between London and Paris is not only quieter and clearer than on a large number of local London wires, but it leaves nothing to be desired. The English land lines are of copper, weighing 400 lbs. per mile, and the land lines on the French side weigh 600 lbs. per mile. The four conductors of the cable (fig. 333) consisting of seven strands of 35 mils wire, each weighs 160 lbs. per nautical mile (2,029 yds.), with a covering of three layers of gutta-percha, alternating with Chatterton's compound, which brings the total weight of each core (conductor and dielectric) up to 460 lbs. per nautical mile, and the diameter to 390 mils. The four cores are twisted, and the diagonal pairs are used for each loop. The sheathing consists of 16 galvanised iron wires 280 mils in diameter:

The effective currents that flow in a metallic circuit are those which are due to the algebraic sum of all the electromotive forces present in the circuit, whether applied by the transmitter or induced by the electro-magnetic and electrostatic conditions present. The rate at which these currents rise and fall, which is the determining element in clear speech, is dependent on the resistances, capacities, and electro-magnetic inertia

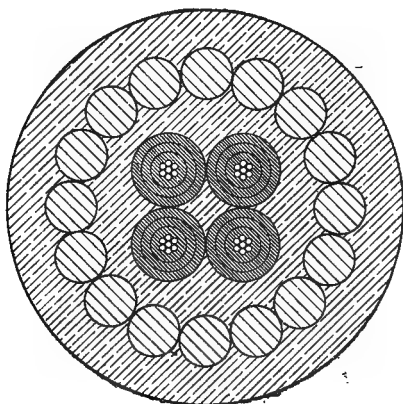

Fig. 333. Full size.

present. Hence the number of complete alternations which can be sent through a circuit is an exceedingly difficult mathematical problem, and one certainly beyond the reach of the ordinary mathematician.

The measured or calculated capacity of a mixed metallic circuit is not to be taken as K , or the true effective capacity. This must vary with every circuit when it is composed of open, underground, and submarine portions of different lengths and in different positions.

The effective K of the London-Paris circuit does not exceed '05 microfarad per mile. There is reason to believe that that of the New York-Chicago circuit does not exceed '04. Hence calculations based on the calculated capacity with reference to earth have led to many serious errors and have excited very amusing criticisms upon the accuracy of the "K R" law. The "K R" law is absolutely correct for submarine and underground circuits when the measured capacity is taken as K ; but, for open and mixed circuits, the effective capacity must be taken; and this is always less than the calculated capacity, for the reasons which have been given.

By no means must it be understood that all has been said that is likely to be known as to the limiting conditions of telephonic speech. On the contrary, it may well be hoped that the near future will give us telephonic powers that are scarcely dreamt of now. It may be said that the best combinations of *instruments* at present known give a limiting distance for good speech that can be fairly represented by a product of capacity and resistance equally distributed of about 8,000. It must be recognised that the design of more efficient instruments is to be expected.

Moreover, there is reason to believe that the beneficial influence of mutual induction in virtually neutralising the effect of capacity will lead to a revolution in long-distance speaking through submarine cables; and it is clear that there is no theoretical reason why speech should not be maintained between Europe and America.

APPENDIX.

JOINT-RESISTANCE SCALE.

TO TAKE THE JOINT-RESISTANCE OF TWO RESISTANCES AT A GLANCE.

Instructions for using the Scale.

Adjust the straight-edge against the value of one resistance marked on the left-hand arm of the Scale, and then set the other end of the straight-edge to the value of the other resistance marked on the right-hand arm.

Read off the value of the inner scale where the straight-edge crosses. **This will represent the Joint-Resistance.**

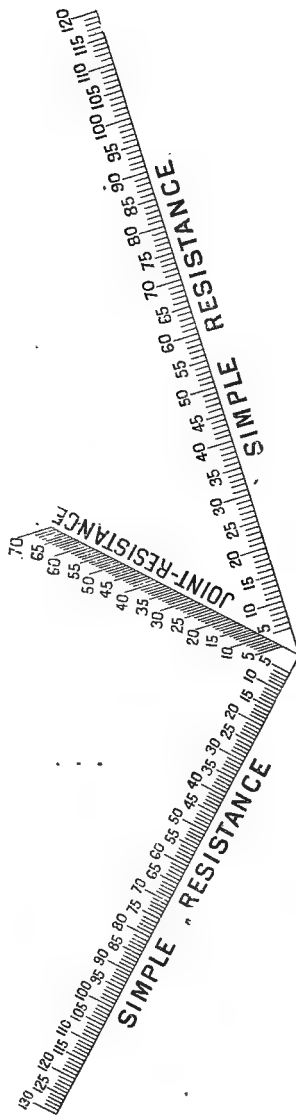

If the two values are very low 100 may be taken as "10" or "1"; and if, on the other hand, they are considerably above 100, the scale figures may be read as of 10 or 100 times their marked value.

(A little practice will ensure considerable accuracy.)

For an explanation of the principle of this scale see page 164.

STANDARD WIRE GAUGE,

Including the DIMENSIONS, WEIGHTS, and RESISTANCES of Cylindrical Pure Copper Wire.

No. S. W. G.	Diameter.		Area in square inches.	Weight. (Spec. Gravity 8.9.)			Resistance.				No. S. W. G.
	Mils (¹⁰⁰ / _{inch})	Milli- metres.		Yards per lb.	Lbs. per yard.	Lbs. per mille.	Ohms per yard.	Ohms per mile.	Ohms per lb.	Yards per ohm.	
7/0	500	12.70	.1953	.441	2.2680	3992	.000124	.2182	.0000547	8065	7/0
6/0	464	11.78	.1691	.512	1.9330	3438	.000144	.2534	.0000737	6945	6/0
5/0	432	10.97	.1466	.590	1.6938	2981	.000166	.2921	.0000979	6024	5/0
4/0	400	10.16	.1256	.690	1.4512	2554	.000194	.3396	.000134	5135	4/0
3/0	372	9.45	.1087	.796	1.2560	2210	.000257	.3942	.000234	4465	3/0
2/0	348	8.84	.0931	.911	1.0990	1934	.000296	.4522	.000311	3892	2/0
0	324	8.23	.0824	1.052	.9521	1676	.000345	.5268	.000422	3378	0
1	300	7.62	.0707	1.224	.8169	1437	.000408	.6072	.000590	2899	1
2	276	7.01	.0598	1.447	.6910	1216	.000489	.7180	.000849	2451	2
3	252	6.40	.0499	1.734	.5766	1015	.000577	.8606	.00118	2049	3
4	232	5.89	.0423	2.046	.4888	860	.000691	1.015	.00169	1733	4
5	212	5.38	.0353	2.452	.4078	718	.000841	1.216	.00251	1447	5
6	192	4.88	.0290	2.984	.3351	590	.001004	1.480	.00358	1189	6
7	176	4.47	.0243	3.563	.2807	494	.001214	1.767	.00523	996	7
8	160	4.06	.0201	4.307	.2322	409		2.136		823	8

STANDARD WIRE GAUGE—continued.

No. S. W. G.	Diameter,		Area in square inches.	Weight, (Spec. Gravity 8.9.)			Resistance.				No. S. W. G.
	Mils (0.01 inch).	Milli-metres.		Yards per lb.	Lbs. per yard.	Lbs. per mile.	Ohms per yard.	Ohms per mile.	Ohms per lb.	Yards per ohm.	
9	144	3.66	.0163	5.313	.1882	331	.001497	2.634	.00795	668.0	9
10	128	3.25	.0129	6.711	.1490	262	.001891	3.328	.01270	528.8	10
11	116	2.95	.0106	8.163	.1225	216	.002302	4.053	.01879	434.5	11
12	104	2.64	.0085	10.183	.09820	173	.002871	5.053	.02925	348.3	12
13	92	2.34	.00665	13.014	.07684	135	.003670	6.459	.04777	272.5	13
14	80	2.03	.00503	17.206	.05812	102	.004852	8.539	.08349	206.1	14
15	72	1.83	.00407	21.263	.04703	82.7	.005995	10.55	.1275	156.8	15
16	64	1.63	.00322	26.882	.03720	65.5	.007578	13.34	.2037	132.0	16
17	56	1.42	.00246	35.186	.02842	50.0	.009918	17.45	.3490	100.8	17
18	48	1.22	.00181	47.824	.02091	36.8	.0135	23.76	.6456	74.09	18
19	40	1.016	.00126	68.681	.01456	25.6	.0194	34.14	1.333	51.55	19
20	36	.914	.00102	87.90	.01178	20.7	.0239	42.06	2.029	41.84	20
21	32	.813	.000804	107.64	.00929	16.3	.0306	53.33	3.262	33.05	21
22	28	.711	.000616	140.46	.00712	12.5	.0393	69.69	5.562	25.25	22
23	24	.610	.000452	191.59	.00522	9.19	.0540	95.30	10.340	18.52	23
24	22	.559	.000380	227.80	.00439	7.73	.0642	113.0	14.625	15.54	24
25	20	.508	.000314	275.45	.00363	6.39	.0777	136.7	21.400	12.87	25
26	18	.457	.000254	341.33	.00293	5.16	.09608	169.1	32.790	10.41	26
27	16.4	.417	.000211	409.90	.00244	4.29	.1157	203.5	47.426	8.644	27
28	14.8	.376	.000172	502.50	.00199	3.50	.1419	249.7	71.305	7.048	28
29	13.6	.345	.000145	595.30	.00168	2.95	.1683	296.1	100.19	5.943	29

STANDARD WIRE GAUGE—continued.

No. S. W. G.	Diameter.		Area in square inches.	Weight. (Spec. Gravity 8.9.)			Resistance.				No. S. W. G.
	Mils (0.01 inch.)	Milli- metres.		Yards per lb.	Lbs. per yard.	Lbs. per mile.	Ohms per yard.	Ohms per mile.	Ohms per lb.	Yards per ohm.	
30	12.4	.315	.000121	714.35	.00140	2.46	.2017	355.0	144.08	4.959	30
31	11.6	.295	.000106	819.80	.00122	2.16	.2302	405.1	188.72	4.344	31
32	10.8	.274	.0000916	943.55	.00106	1.86	.2664	468.8	251.36	3.754	32
33	10.0	.254	.0000785	1102.5	.000907	1.60	.3108	546.9	343.45	3.218	33
34	9.2	.234	.0000665	1302.8	.000768	1.35	.3670	645.8	478.13	2.725	34
35	8.4	.213	.0000555	1560.6	.000641	1.13	.4396	773.7	686.04	2.275	35
36	7.6	.193	.0000454	1904.8	.000525	.923	.5375	945.8	1023.80	1.861	36
37	6.8	.173	.0000363	2386.6	.000419	.738	.6720	1182.	1603.99	1.488	37
38	6.0	.152	.0000282	3067.5	.000326	.573	.8652	1523.	2653.56	1.156	38
39	5.2	.132	.0000212	4081.6	.000245	.431	1.151	2026.	4697.92	.8689	39
40	4.8	.122	.0000181	4784.7	.000209	.368	1.348	2372.	6449.78	.7419	40
41	4.4	.112	.0000152	5681.8	.000176	.309	1.605	2824.	9119.29	.6232	41
42	4.0	.102	.0000126	6849.3	.000146	.256	1.937	3409.	13267.	.5163	42
43	3.6	.0914	.0000102	8474.6	.000118	.207	2.392	4210.	20272.	.4181	43
44	3.2	.0813	.00000804	10764.2	.0000929	.163	3.035	5341.	32658.	.3295	44
45	2.8	.0711	.00000616	14045.	.0000712	.125	3.961	6972.	55632.	.2525	45
46	2.4	.0610	.00000452	19157.	.0000522	.0919	5.398	9500.	103405.	.1853	46
47	2.0	.0508	.00000314	27550.	.0000363	.0638	7.771	13370.	217069.	.1287	47
48	1.6	.0406	.00000201	43103.	.0000232	.0408	12.142	21378.	523357.	.08238	48
49	1.2	.0305	.00000113	76336.	.0000131	.0230	21.590	38000.	1648094.	.04632	49
50	1.0	.0254	.000000785	110253.	.00000907	.0160	31.080	54695.	3426632.	.03218	50

The foregoing Table has been calculated on the following data:—

WEIGHT.

Specific Gravity of Soft Copper 8.9. Taking the weight of a cubic foot of water at 62° F. as 62.2786 lbs., in accordance with the determination of the Standard Department of the Board of Trade (1890), this makes the weight of 1 cubic foot of Soft Copper at 62° F. 554.280 lbs.; and at 60° F. about 554.283 lbs.

RESISTANCE.

A length of 1 foot of Soft Copper weighing 1 grain gives a resistance at 60° F. (15.5° C.) of .2190 ohm. (The Reports of the British Association Committee on Electrical Standards (p. 228) give .2186 B.A. Unit for 15° C. and .2194 for 16° C.)

HARD COPPER.

At 60° F. the resistance of Hard Copper is approximately 2 per cent. greater than that of Soft Copper.

WEIGHT OF CIRCULAR WIRES, ETC.

To ascertain the Weight per MILE of any Material of uniform section: Weigh a Length of 9.05 inches in grains or a Length of 20 feet 7½ inches in drams. The result in each case will give the WEIGHT PER MILE in LBS.

Similarly, the Weight in grains of a Length of 10.7/16 inches, or in drams of 23 feet 9.5/16 inches, will give the WEIGHT PER KNOT in LBS. (A knot is 2,029 yards.)

These Weights are exact for the Lengths given for Weight in drams and correct within .02 per cent. in the case of the grains.

TO CONVERT ENGLISH MEASURES INTO THE DECIMAL SYSTEM, AND *VICE VERSA*.

Measures.	Multiplier.	Reciprocal.	Log. of Multiplier.
LENGTH.			
Mils into Millimetres ...	·025399	39'37	2̄·40483
Inches „ „ ...	25'39954	·03937	1'40483
„ „ Centimetres ...	2'53995	·3937	0'40483
Feet „ Metres ...	·30479	3'2809	1'48401
Yards „ „ ...	·91438	1'0936	1'96113
Miles „ Kilometres ...	1'60931	·62138	0'20664
AREA.			
Square Mils into Square Millimetres	·0006451	1550'059	4̄'80965
Square Inches into Square Centimetres	6'45137	·155	0'80965
WEIGHT.			
Grains Troy into Grammes	·064799	15'432	2̄'81157
Ozs. Avoirdupois into Grammes	28'3495	·03527	1'45255
Lbs. Avoirdupois into Grammes	453'5926	·002204	2'65667
Lbs. Avoirdupois into Kilogrammes	·45359	2'20462	1̄'65667
LENGTH and WEIGHT.			
Yards per Lb. into Metres per Gramme •	·002016	496'063	3̄'30449
Grains per Foot into Grammes per Metre ...	·2126	4'7037	1̄'32756
Ozs. per Foot into Grammes per Metre ...	93'01	·01075	1'96852
Lbs. per Foot into Grammes per Metre ...	1488'19	·000672	3'17266
Lbs. per Yard into Grammes per Metre ...	496'063	·002016	2'69554
Lbs. per Mile into Grammes per Kilometre	281'85	·0035479	2'45003

TO CONVERT ENGLISH MEASURES INTO THE DECIMAL SYSTEM, AND *VICE VERSA*—*continued.*

Measures.	Multiplier.	Reciprocal.	Log. of Multiplier.
RESISTANCE.—			
Ohms per Yard into Ohms per Metre	1·0936	·91438	0·03886
Ohms per Mile into Ohms per Kilometre	·62138	1·60931	̄1·79336
Ohms per Lb. into Ohms per Gramme	·0022046	453·5926	̄3·34333
Yards per Ohm into Metres per Ohm... ..	·91438	1·0936	̄1·96113
Miles per Ohm into Kilo- metres per Ohm... ..	1·60931	·62138	0·20664
Lbs. per Ohm into Grammes per Ohm... ..	453·5926	·0022046	2·65667

INDEX.

(N.B.—Names are separate, and follow Subjects under each Letter.)

INDEX.

(N.B.—The Names are separate, and follow the Subject under each Letter.)

A.

- A.** B.C. Instrument compared with Telephone, 229
Adjusting Clamp for Receivers, 58
Adjustment for Trembler Bells, 131
Advantages of "Bridge" or "Leak" Working, 159
Aerial Cables, 448, 450
——— Post Office, 451
——— Cable Suspenders, 430
——— Lines, Wire for Telephone, Chap. xxix. 437-447
Altandi Electro-magnet, 192
American Conference Standard Cable, 454
——— Cord-peg and Spring Switchboard, 179
Anti-induction System, Van Rysselberghe's, 375
Armature, Siemens', 122
Arm-rest, 228
Army, Use of Telephony in, 364
Arresters, Lightning, 115
"Artificial Line" for Telephonic Experiments, 105
Attendance, Night, at Exchanges, 226
Austrian Lightning Protector, 115
Automatic Call-boxes, 346
——— Cut-outs for Generators, 125
——— Switch, 113
——— Switchboard, Ericsson's, 394
Aberdeen Exchange, Miller's Call Wire System at the, 242

- Abrezol's Investigation of Induction Coils, 107
Ader, on Sensitiveness of Be Telephone, 23
———'s Receiver, 45, 366
———'s Selective Signal System 389
———'s Transmitter, 64
Anders-Elliott Domestic Switchboard, 379

B

- B**alancing-resistances for "Bridge"-working, 160
Batteries, 120
Battery for Microphone Circuit, 144
Battery-power, Calculation of, for "Bridge"-working, 162
"Beaded" Cables, 470
Belgian Administration and Van Rysselberghe's System, 360
Bell, Call, 129
——— Resistance of, 131, 136
——— Magneto, 136
——— Trembler, 130
——— with Automatic Cut-out, 134
——— Circular Pattern, 135
——— Continuous-ringing, 133
——— Extension, 134
——— with Indicator, 132
——— Whittington, 135
Binders for Copper Wire, 428
———, Post Office "Tape," 429
Bi-telephone, Mercadier's, 57
Blocks, Wall, and Plugs, 142

Boards, Cross-connection or Distributing, 315, 316, 323
 ——— Intermediate Distributing, 325
 ——— Records of Connections, 321
 ——— Test-, etc., Chap. xx. 314, 328
 Breaking Stress of Copper Wire, 444
 ——— of Steel Wire, 438
 ——— Weight, 444
 Breast Transmitter, 299
 "Bridge" Intermediate Switch, Post Office, 165
 ——— System for Intermediate Stations, 158
 Britannia Joint, 426, 427
 "Buzzer," Calling Subscriber by, 219
 Buzzing Signals, 370

Baker's Fluid, 426
 Barbier-Leclanché Cells, 121
 Bell, Alexander Graham, 3
 Bell-Blake Telephone, 147
 Bell Telephone, Chap. ii. 15-29
 ——— Early Forms of, 15
 ——— Magnetic Field of, 28
 ——— Principle of Working, 21
 ——— Sensitiveness of, 23
 ——— Theoretical Construction of, 27
 ——— Telephone, Theories of, 22
 Bennett and Maclean's Call-wire Plan, 243
 ———'s Multiple Switch, with Call Wire, 298
 ——— Ring-through System, 210
 ——— Translators, 332
 ——— Two-section Induction Coil, 304
 Berliner's "Universal" Transmitter, 83, 105
 ——— Magneto Set, 149
 Bert and D'Arsonval's Transmitter, 65
 Berthon's Ring-through System, 210
 ——— Transmitter, 85, 366
 Bidwell, Shelford, on Microphone, 37
 Bizot's Pendulum Call, 139, 389
 Blake's Transmitter, 71, 104, 190

Blakey, Emmott's Call-box, 350
 Bottomley's Twisted Wires, 412
 Bourseul, Charles, 2
 Boudet's Transmitter, 79
 Bréguet, Antoine, on Sensitiveness of Bell Telephone, 23
 ———'s Mercury Telephone, 98
 British Insulated Wire Co.'s Paper Cables, 453
 Brown and Saunders' Signaller, 137
 Buenos Ayres and Monte Video Cable, 469
 Burnley's Transmitter, 80

C.

Cabinets, Silence, 227, 341
 ——— Test, 323
 Cable Racks for Switchboards, 310, 311
 ——— Suspenders, Aerial, 430
 ——— Terminal Tablet, 457
 ——— Junction with open Line, 434
 ——— London-Paris Telephone, 480
 ——— Aerial, 448, 450
 Cables, Anti-induction, 457
 ——— "Beaded," 470
 ——— Capacity of, 451, 452, 453, 457, 462, 465, 468, 471, 480
 ——— Dry Core, 456, 463
 ——— Insulation of, 452, 453, 454, 471
 ——— KR of Metallic Circuits, 475
 ——— Paper, 453, 456, 467
 ——— Post Office, 451, 452
 ——— Resistance of, 451, 465, 471, 480
 ——— Speaking efficiency of, 474
 ——— Switchboard, 305
 ——— Telephone, Chap. xxx. 448-471
 ——— Underground, 450, 452
 Calculation of Battery-power for "Bridge"-working, 162
 ——— ; Joint-resistance Scale, 163
 Calling Subscriber by "Buzzer," 219

- ' Call " by Reaction of Transmitter and Receiver, 92
- Call-Bell, 129
- Magneto, 136
- ——— Resistance of, 131, 136
- Trembler, 130
- with Automatic Cut-out, 134
- Circular Pattern, 135
- Continuous-ringing, 133
- "Extension," 134
- with Indicator, 133
- Whittington, 135
- Call Keys, 196, 283
- Boxes, Automatic, 346
- Offices, Telephone, Chap. xxii. 341-351
- Call-wire Systems, Chap. xiv. 232 244
- Bennett & Maclean's, 243
- Law, 232
- Mann, 234
- Miller's, 241
- Multiple Switch, 298
- Cam-lever Table Keys, 199
- Capacity, "Effective," of Cables, 478, 481
- Electro-static, 440, 441
- of Cables, 451, 452, 453, 457, 462, 465, 468, 471, 480
- of Foiled Conductors, 449
- Ultimate, of Multiple Switch, 258, 261
- Carbon Transmitter, Edison's, 30
- Invention of, 5
- Use of, for Transmitters, 60
- Variable Resistance of, 30
- Transmitters, Chap. v. 60-92
- Circular Pattern Table Telephone, 152
- Trembler Bell, 135
- Clamp, Adjusting, for Receivers, 58
- Coils, Induction, 12, 33, 103, 107, 109, 288
- Commutated Magneto, 129
- Conductivity of Copper and Iron, 439
- "Conference" Standard Cable, 454
- Construction of Lines, Chap. xxviii. 409-436
- Continuous-ringing Call-Bell, 133
- Conversion Table for Decimal System, 490
- Copper Wire, Breaking Stress, etc., 439
- Care in Handling, 443
- Dimensions, Weights, and Resistances of, 486
- Speaking Efficiency of, 474
- Specification, Post Office, 444
- Cord-peg and Spring Pattern of Switch, 179
- Cords, Peg, Testing of, 227
- Counter-communication Switch, 342
- Cross-connecting Boards, 315, 323
- "Cross-over" System on open Lines, 416
- Cut-in for Carty's Generator, 128
- Cut-outs, Automatic, for Generators, 125
- C**ailho's Simultaneous Telegraphy and Telephony, 363
- Cardew, Major, Military Telephony 363, 367
- Vibrator System, 367
- Carty's Connections for Generators, 128
- Chincock Exchange Switch, 180
- Clark's "Britannia" Joint, 426
- Clérac's Variable Resistance, 31
- Coleman & Jackson Translator, 333
- Collier's Receiver, 53
- Consolidated Telephone Co.'s Bell-Blake Telephone, 147
- Circular Pattern Bell, 135
- Domestic Switch-board, 373
- Generator, 122
- Small Exchange Switch, 180
- Table Telephone, 152
- Cotterell's Automatic Call-box, 349
- Crossley's Transmitter, 61
- Cross, Professor Charles, Tests of Transmitters by, 103

D.

- D**ecimal System, Conversion Table for, 490
 Desk for Silence Cabinet, 228
 Detector for P.O. Multiple Switch, 291
 ——— Peg for P.O. Multiple Switch, 286, 291
 Dielectrics, Low-capacity, 451
 Differential System for Intermediate Stations, 157
 Dip or Sag of Wires, 418
 Direct Switchings, Percentage of, in an Exchange, 206, 247
 Distance, Limiting, of Speech, Chap. xxxi. 472-481
 Distributing Board, 315, 318, 323
 ——— Intermediate, 325
 Domestic Switchboards, Chap. xxvi. 373-385
 ——— Anders-Elliott, 379
 ——— Consolidated, 373
 ——— "Line-selectors," 381
 ——— Sloper's "Secret," 383
 ——— Western Electric, 378
 Double-pole Bell Receiver, 51
 Drawing-in Cables, 454, 465
 Draw-tongs, 419
 "Dry" Cells, 121
 ——— Core Cables, 455, 463
 Dynamometer for Wires, 419
- D**anvers Indicator, 182
 D'Arsonval's Receiver, 47
 ——— Transmitter, 65, 105
 De Bonneville, 388
 Deckert and Momolka Transmitter,
 De Jongh "Watch" Receiver, 53
 ——— Transmitter, 66, 104
 De la Rive, 2
 De la Touanne's Formula for Proportion of Direct Through Switching, 207
 Dewar Table-keys, 190, 194
 Dolbear's Receiver, 101
 Du Moncel, 2
 ——— on Bizot's Pendulum Call, 139
 ——— Discovery of Variable Resistance of Carbon, 30
 ——— on Relation between Magnet and Armature, 46

- Du Moncel on Theory of Bell Telephone, 23
 Dundee, Call-wire System at, 234, 240

E.

- E**arth Connection, 434
 ——— Resistance of, 435
 ——— Currents in Single Wires, 410
 ——— Switch for Single Cord Multiple Board, 262
 "Effective" Capacity of Cables, 478, 481
 Efficiency of Transmitters and Induction Coils, Comparative, Chap. vii. 103-110
 Elasticity of Wires, 424
 ——— Limit of, 444
 Elbow Rest, 228
 Electrical Properties of Copper Wire, 440
 Electric Light in Silence Cabinets, 228
 Electrification, 452
 Electro-dynamic Induction, 11
 ——— magnetic Inertia 158, 440
 ——— 473
 ——— Switch, 403
 Electro-motograph, Edison's, 96
 ——— static Capacity, 440, 441
 ——— of Cables, 451, 452, 453, 457, 462, 465, 468, 471, 480
 "Engaged" Test, 254, 264, 265, 270, 273, 282, 289, 303
 English Measures and Decimal System, 490
 Exchange Intermediate Switch, 222, 292
 Exchanges, Ring-through Systems for, 210
 ——— Switchboards for small, Chap. xi. 179-188
 ——— Ordinary, Chap. xii. 189-212
 Exchange Switchboards, American Cord and Peg Pattern, 179
 ——— Chinnock, 180
 ——— Consolidated, 180
 ——— English Post Office, 213

Exchange Switchboards, Standard,
184, 189, 191
——— Swiss Commutator
Pattern, 179
Expansion, Co-efficients of, for Line
Wires, 422
Extension Bells, 134

Edison, Thomas Alva, Invention
of Carbon Transmitter, 5
———'s Application of Induction
Coil, 33
——— Electro-motograph, 96
——— Superposing System, 362
——— Transmitter, 30, 104
Elsässer's Translator System, 335
Emmot's Ring-through System,
211
——— Automatic Switchboard, 394
Ericsson-Bell Generator Cut-out,
125
——— Micro-Telephone, 154
——— Table Telephone, 151
——— Wall Telephone, 149

F

Fees for Use of Call-office Tele-
phones, 347
Fittings, Wall, 141
Foucault Currents, prevention of, in
Collier Receiver, 53
French Chalk for Drawing-in
Cables, 454
——— Trembler Bell with In-
dicator, 133
——— Twisted Wire System, 417

Faraday, 9
Felten & Guilleaume Cables,
465
Forbes' Thermal Transmitter, 101
Fortin-Herrmann "Beaded" Cable,
470
Fowler-Waring Cables, 463
Freeman's Transmitter, 78

G

Galvanised Wire, 438
Galvanometer, "Telephone,"
231

Gauge, Standard Wire, 486
Gearing for Magneto Generators,
126
Generators, Magneto, 121
——— for Exchanges, 196
German Intermediate Switch, 168
——— Lightning Protector, 116
"Granular" Transmitters, 81

Garnier, 3
Gassiot, 2
General Electric Co.'s Domestic
Switch-board, 383
——— "Tag" for Flexible
Cords, 52
——— Wall Block, 142
——— "Whittington"
Bell, 135
Genest, Mix &, Call-box, 349
Gent's Transmitter, 75
Gerald on Theory of Bell Tele-
phone, 24
Gilliland Automatic Cut-out for
Generators, 125
Glasgow Exchange, Miller's Sys-
tem, 242
Glover's Cable Suspender, 432
——— Cables, 457
Goloubitzsky's Receiver, 48
Gower-Bell Telephone (complete),
143
——— Transmitter, 62
Gower's Receiver, 40
Gray, Elisha, Speaking Telephone,
3
——— Superposing System, 362
Guillemin, 2

H.

"**H**ead-gear" Telephones, 55,
299
"Home" Section of Multiple
Switch, 289

Heaviseide, Oliver, on the
Magnetic Field of the Bell
Telephone, 28
Heys, W. E., Twisted Wires, 412
Highton, H. & E., 387, 388
Hooke, Robert, 1
Hunning's Transmitter, 81, 104

- Hunning-Bell and Magneto Telephone, 148
 ——— "Cone" Transmitter, 91
 Hughes, Prof. D. E., Invention of Microphone, 5
 ——— Microphone, 34, 61
 ——— on the Properties of Copper Wire, 440

I.

- Impedance, 158
 ——— In-coming Cables, 315
 ——— Trunk or Sub-trunk Wires, 337
 Indicator, Danvers Pattern, 182
 ——— Post Office "Polarised," 215
 ——— Post Office, for Multiple Switch, 286
 ——— "Ring-off," 193, 281
 ——— "Self-restoring," 278
 ——— and Translator, Coleman & Jackson's, 333
 ——— Western Electric, 186
 Individual Signals, Selective or, Chap. xxvii. 386-406
 ——— Ader's System, 389
 ——— Ericsson's, 394
 ——— Johnston Stephen's, 399
 ——— Post Office, 403
 "Individual" Switch-springs, 250, 289
 Induction, Chap. i. 9-14
 ——— Coils, Abrezol's Investigations, 107
 ——— Application to Telephone, 33
 ——— Comparative Efficiency of some, 103
 ——— Post Office, 288
 ——— Investigations, 109
 ——— Two-section Secondary (Bennett's), 304
 ——— Winding of, 12
 ——— Mutual, of Looped Wires, 479
 ——— Neutralisation of, by Twisted Wires, 412
 ——— "Speaking," Prevention of, 305

- Induction System, Van Rysselberghe's Anti-, 357
 "Instrument" Peg, P. O. Multiple Switch, 290
 Insulation of Cables, 452, 453, 454, 471
 ——— of Lines, 409
 Intermediate Distributing Board, 325
 ——— Stations, Chap. x. 156-176
 ——— Advantages of "Bridge" System, 158
 ——— Calculation of Battery-power, 162
 ——— German Switch, 168
 ——— Joint-resistance Scale, 164, 485
 ——— "Leak" Switches, 174
 ——— Miller's Switch, 173
 ——— Ordinary, Differential, and "Bridge" or "Leak" Systems, 157
 ——— Post Office Switch, 165
 ——— Principles of Bridge-working, 160
 ——— Three-lever Switch, 172
 ——— Switch, Post Office Exchange, 222, 292
 Iron Wire, 438
 ——— Line, Speaking Efficiency of, 474

J

- Joint-resistance Scale, 163, 485
 Joints in Open Wires, "Britannia," 426
 ——— German form, 426
 ——— McIntire's, 426
 ——— Weight of, 427
 Junction of Open Line and Cable, 434
 ——— or Sub-Trunk Wires, 336
 ——— Wires, Number worked by one Operator, 340
 Jacob's System of Multiplex Telephony, 353, 363
 Jackson, Coleman and, Translator, 333
 "Johnson" Transmitter, 70
 Johnston-Stephen's Selective Signaller, 399

K

- Keys**, Cam-lever, 199
 — Dewar Table, 190, 194
 — Ringing, 196, 283
 — for Single-cord Switchboard, 262
 — Table, 190, 194, 199, 283
Knot, Weight of, from Short Length, 489
"KR" Limit of Speech, 473, 481
 — with certain Induction Coils, 109
 — of Metallic Circuit, 475
 — Rule as to Limit of Speech on certain Transmitters, 105

- Kelvin**, Lord, 3
 — Time-constant, 472
Kempe, H. R., on the "KR" of a Metallic Cable Circuit, 475

L

- Law**, Kelvin's Time-constant, 472
 — Lenz's, 11
Lead Covering for Cables, 451
Leading-in Cables, 314
"Leak" Intermediate Switches, 174
 — System for Intermediate Stations, 158
 — Working for Exchanges, 198
Lightning Protectors, or Arresters, 115, 316
Limit of Clear Articulation on Telephone ("KR" Rule), 106
 — of Elasticity, 444
Limiting Distance of Speech, Chap. xxxi. 472-481
Lines, Construction of, Chap. xxviii. 409-436
 — Wire for Telephone Aerial, Chap. xxxix. 437-447
Line Selector (Switchboard), 381
"Local" Switch-springs, 250, 289
 — Order of Connection, 312, 325
 — "Redistribution" of, 325
- Law** "Call Wire" Plan, 232
Leclanché Battery, 120

- Lenz's Law**, 11
Liverpool Translator, 333
Locht-Labye's Transmitter, 75
Lockwood on Selective Signals, 386
London-Paris Telephone Circuit, 479
 — Line, Use of Secondary Cells, 121
London Stock Exchange Call-office System, 345

M

- Magnetic** Field, 9
 — of Bell Telephone, Heaviside on, 28
 — of the Earth, Effect on Telephone Lines of, 443
 — "Tick," 2
Magneto Call Bells, 136
 — electric Induction, 11
 — Generators, 121
 — Commutated, 129
Mercury Telephone, Bréguet's, 98
Messages by Telephone, 225, 227, 228
Metal-cased Blake Transmitter, 73
Metallic Circuit Switchboards, 203, 268
 — Circuits, 411
 — Telephone Circuit on two Telegraph Wires, 360
Microphone Circuit, Battery for, 144
 —, Bidwell on Material for, 37
 — Hughes', 34
 — Invention of by Hughes, 5
 — Stroh on Theory of, 38
Micro-Telephones, 154, 221
Mile, Weight of, from Short Length, 489
Military Telephony, Chap. xxv. 364-372
Mixed System of Metallic Circuits and Single Wires, 205
Multiple Switchboards, Single Wire, Chap. xv. 247-267
 — Additional Half-sections, 262
 — "Engaged" Test, 254, 266, 270, 282, 289, 303
 — General Arrangement of Parts, 249

Multiple Switchboards, Oesterreich's, 265
 ——— Operators, Number required, 259, 265, 276
 ——— Peg-connections, 255, 263, 269, 275, 281, 301
 ——— Principle of, 248
 ——— Single-cord (Scribner's), 262
 ——— Space required for, 258
 ——— Spring-strips, 252, 272, 297
 ——— "Ultimate Capacity" of, 258, 261
 ——— Metallic Circuit, Chap. xvi. 254-283
 ——— "Branching," 275
 ——— with Call-circuit System, Chap. xviii. 298-304
 ——— with Distinct "Engaged" Test, 271
 ——— Post Office, Chap. xvii. 284-297
 ——— "Self-restoring" Indicator, 278
 ——— Single Spring Switch, 268
 Multiplex Telephony, Chap. xxiii. 352-355
 ——— Jacob's System, 353
 ——— Rosebrugh's System, 355
 Multipolar Receivers, 48
 Musical Telephone, 3
 Mutual Induction of Looped Wires, 479

Maclean's, Bennett &, System, 243
 Maiche's Transmitter, 74
 Mann Call-wire Plan, 234
 McIver, Poole &, Call-box, 349
 Mercadier's Bi-telephone, 57
 ——— on Theoretical Construction of Bell Telephone, 27
 ——— on Theory of Bell Telephone, 24
 Mix & Genest's Adjusting Clamp for Receivers, 58
 ——— Automatic Call-box, 349
 ——— Table Telephoné, 151
 ——— Transmitter, 67, 105
 ——— Wall Rosettes, etc., 142
 Miller's Call-wire Plan, 241

Miller's Condenser Device on Pole-changers, 198
 ——— Intermediate Switch, 173
 Moncel, Du, 2
 ——— and Variable Resistance of Carbon, 30
 ——— on Theory of Bell Telephone, 23
 Monte-Video and Buenos Ayres Cable, 469
 Moseley's Transmitter, 82
 ——— Twisted Wire System, 412

N

Names of Subscribers to Exchanges, 225
 Night Call on Call-wire System, 239
 ——— at Exchange, 226
 Noise in Exchange, Avoidance of, 227
 Numbering Device for Cable Conductors, 459
 Numbers for Exchange Subscribers, 225, 325
 Number of Ring-off Indicators per Switch-Section, 260
 ——— of Subscribers per Operator, 226, 260, 265, 276
 ——— of Trunk-wires per Operator, 340
 ——— of Wires on Arm, 416

National Co.'s Bell-Blake Telephone, 147

——— Cable Rack, 311
 ——— Metallic Circuit Multiple Switch, 271
 ——— Silence Cabinet, 342
 ——— Test Board, etc., 322
 ——— Testing System, 326
 ——— Translator, 332
 ——— Translator System, 336
 ——— and the Call-wire System, 234, 241
 Neumayer's Receiver, 50

O

Operator, Number of Subscribers for each, 226, 260, 265, 276

Operator, Number of Trunk and Sub-trunk Wires, 340
 —s, Number at Multiple Switch Section, 259
 —'s Speaking Peg, Post Office, 286, 290
 Out-going Trunk or Sub-trunk Wire, 337

Oesterreich's Multiple Switch, 265

P

"Paper" Cables, 453, 456, 467
 Patent Specifications, British—
 Bell Telephone, 15
 Berthon Transmitter, 85
 Blake Transmitter, 71
 Carty's Generator, 128
 Collier Receiver, 53
 Crossley Transmitter, 61
 De Jongh Transmitter, 66
 Domestic Switchboard, Anders-Elliott, 379
 — — Consolidated, 373
 — — Sloper's, 383
 Edison Transmitter, 31
 Gower Receiver, 40
 Hunning Transmitter, 81
 Jacob's Multiplex Telephony, 353
 Moseley Transmitter, 82
 Multiple Switchboards, 247, 265, 275, 298
 Rosebrugh's Multiplex Telephony, 355
 Saunders & Brown's Signaller, 137
 Symmetrical Twist of Open Wires, 412
 Telephone Paper Cables, 456
 Translators or Transformers, 332
 Pegs for Switchboards, 185, 200, 214, 278, 286, 290, 291, 299
 —, Test, 326, 327
 Pendulum Call, Bizot's Device, 139
 — Selective Signaller, Johnston-Stephen's, 399
 — Signaller, 137
 Percentage of Direct Switchings in an Exchange, 206, 247
 "Permanent Current" Exchange Working, 218
 Phosphor-bronze Wire, 440

"Point" Lightning Protector, 119
 "Polarised" Indicator, Post Office Pattern, 215
 Pole-changers for Calling, 196
 Post-pattern Generator Cut-out, 126
 Protectors, Lightning, 115

Page "Magnetic Tick," 2
 Paris-London Telephone Circuit, 479
 Patterson Cables, 455
 — Cable Suspender, 432
 Peirce, Professor, Application of Small Magnets to Bell Telephone, 19
 Pellatt on Sensitiveness of Bell Telephone, 26
 Phelps, Suggestion of Multipolar Receivers, 48
 Picard's Simultaneous Telegraphy and Telephony, 361
 Poole and McIver Call-box, 349
 Poole's Ring-through System, 211
 Post Office Aerial Cable, 451
 — — "Bridge" Intermediate Switch, 165
 — — "Buzzer" Call, 219
 — — Call-offices, 342
 — — Copper Wire Specification, 444
 — — Counter-communication Switch, 342
 — — Exchange Intermediate Switch, 222
 — — — Switch, 214
 — — — System, Chap. xiii. 213-231
 — — Experimental Comparison of Transmitters, 105
 — — — Induction Coils, 109
 — — Experiments with Superposing Systems, 363
 — — Intermediate Offices, 156
 — — Lightning Protector, (Single), 115
 — — — (Double), 116
 — — — ("Point"), 119
 — — Multiple Office System, 403
 — — Multiple Switch, Chap. xviii. 284-297

- Post Office "Permanent Current" System, 217
- — Polarised Indicator, 215
- — Receiver Terminals, 51
- — Ring-through System, 211
- — Silence Cabinets, 227
- — Switchboard Telephone, 221
- — System of Cord-testing, 227
- — "Tape" Binder, 429
- — Telephone, 146
- — Telephone Induction Coil, 110, 288
- — Telephone Relay, 140
- — "Through Tablets," 222
- — Trembler Bells, 130
- — Trunk Exchange System, 297
- — Trunk Wires, 224
- — Underground Cable, 452
- — "Universal Telephone" Connections, 146, 160
- — Use of Telephone for Telegraph Work, 228
- Preece on Sensitiveness of Bell Telephone, 26
- on "Shielded" Wires, 449
- on Speed of Transmission in Iron and Copper Wires, 440
- 's Thermo-Telephone Receiver, 100

R.

- Racks, Cable, 310, 311
- Reaction between Transmitter and Receiver, Call by, 92
- Receivers, Telephone—
- Ader's, 45
- Adjusting Clamp for, Mix & Genest's, 58
- Bréguet's Mercury, 98
- Collier's, 53
- D'Arsonval's, 47
- De Jongh "Watch," 53
- Dolbear's, 101
- Double-pole Bell, 51
- Goloubitzky's, 48
- Gower's, 40
- "Head-gear," 55, 299

- "Head-gear," Siemens', 56
- Mercadier's Bi-telephone, 57
- Neumayer's, 50
- Preece's Thermal, 100
- Reis', 93
- Resistance of, 20, 54
- Siemens', 42
- with "Siren Call," 44
- "Watch," 53
- Western Electric, 51
- Records of Test-board Connections, 321
- Redistribution of "Local" Switchsprings, 312, 325
- Refunding Device, 350
- Regulation of Open Wires, 420
- Relation between Magnet and Armature, Du Moncel on, 46
- Relays, 139, 161
- Repetition and Spelling to insure Accuracy, 226
- Research, Examples of Telephonic, Chap. vi. 93-102
- Resistance of Cables, 451, 465, 471, 480
- of Copper Wire, 446, 486
- of Earth-connection, 436
- of Generator Coils, 124
- of Lead-foil Cable Coatings, 461
- of Phosphor- and Silicium-Bronze Wire, 447
- of Relays, 141, 162
- of Steel Wire, 438
- of Telephone Receivers, 20, 54
- of Translators, 332
- of Trembler Bells, 131, 136
- , Spurious, 14
- Balancing, on "Bridge" System, 160
- Rest, Elbow, 228
- Retardance in Circuits, 473
- Ringing Keys, 196, 283
- Range of Generators, 126
- Ring-off Indicators, 193, 203, 281
- Number required, 260
- Ring-through Systems for Exchanges, 210
- on Translator Circuits, 333, 335
- Rosettes, etc., Wall, 141

Reis, Philip, 2
 ——— Receiver, 95
 ——— Transmitter, 93
 Rive, de la, 2
 Rosebrugh's Multiplex Telephony,
 355
 Rothen on Tests of Transmitters,
 103
 Roulez's Transmitter, 83

S.

Sag or Dip of Wires, 418
 Sags and Stresses, Table of, 421
 Secondary Cells for Telephony, 121
 ——— Currents, Direction of, 12
 "Secret" Switch, Sloper's, 383
 Selective or Individual Signals,
 Chap. xxvii., pp. 386-406
 ——— Ader's, 389
 ——— Ericsson's, 394
 ——— Johnston-Stephen's, 399
 ——— Post Office, 403
 Self-induction, 13
 ——— Co-efficient of, 14
 "Self-restoring" Indicator, 278
 Sensitiveness of Bell Telephone,
 Ader's Experiments, 23
 ——— Bréguet's Experiments, 23
 ——— Pellatt on, 26
 ——— W. H. Preece on, 26
 ——— Dr. Werner Siemens on, 25
 Serrated Lightning Protectors, 115
 Signaller, Pendulum, 137
 Signals, Selective and Individual,
 Chap. xxvii., pp. 386-406
 ——— Ader's, 389
 ——— Ericsson's, 394
 ——— Johnston-Stephen's, 399
 ——— Post Office, 403
 Silence Cabinets, 227
 "Silent-gear" Generators, 126
 Silicium-Bronze Wire, 446
 "Siren Call," Siemens', 44
 Simultaneous Telegraphy and Tele-
 phony, Chap. xxiv., 356-363
 ——— Cailho's, 363
 ——— Picard's, 361
 ——— Van Rysselberghe's,
 357
 Single-cord Switchboard, 200
 ——— Multiple, 262

Snow, Deposits of, on Wires, 425
 Soldered Connections Desirable,
 316
 ——— on Lines, 416
 "Solid-Back" Transmitter, 89,
 110
 Speaking Circuits for Trunk-wire
 Working, 337
 ——— - efficiency of Telephone
 Line, 473, 474
 "Speaking Induction," Prevention
 of, 305
 Speaking Tablet, 221
 Specification for Copper Wire, Post
 Office, 444
 Specifications, Patent (*see* Patent
 Specifications, British).
 Specific Gravity of Copper, 486
 Speech, Limiting Distance of,
 Chap. xxxi., 472-481
 "Spring-Jack" Exchange Switches
 184
 "Spurious" Resistance, 14
 Standard Cable, American Con-
 ference, 454
 ——— Wire Gauge, etc., 486
 Steel Wire, Qualities of, 438
 Strain, 443
 Stress, Breaking, of Copper Wire,
 ——— 439, 445
 ——— of Steel Wire, 438
 Stresses and Sags, Table of, 421
 "Swiss Commutator," 179
 Switch, Automatic, 113
 ——— Electro-magnetic, 403
 ——— German Intermediate, 168
 ——— "Leak" Intermediate, 174
 ——— Miller's Intermediate, 173
 ——— Post Office "Bridge"
 Intermediate, 165
 ——— ——— Counter-Com-
 munication, 342
 ——— ——— Exchange Inter-
 mediate, 222, 292
 ——— Table, 243, 299
 ——— Three-lever Intermediate,
 172
 Switchboard Cables, 305
 ——— Telephone, Post Office, 221
 ——— Through Tablets, 222
 ——— Transmitter, Blake, 73
 Switchboards, Automatic, Ericsson's,
 394

Switchboards, Domestic, Chap. xxvi., 373-385
 ———— Metallic Circuit, with Call-circuit System, Chap. xviii., 298-304
 ———— Multiple, Chap. xvi., pp. 268-283
 ———— Post Office, 213
 ———— Multiple "Branching," 275
 ———— Post Office, Chap. xvii., 284-297
 ———— with Distinct "Engaged" Test, 271
 ———— Oesterreich's Multiple, 265
 ———— for Ordinary Exchanges, Chap. xii. 189-212
 ———— Double Wire, 203
 ———— Mixed System of Metallic Circuits and Single Wires, 205
 ———— Single Cord, 200
 ———— Single Wire, 191
 ———— Standard, 189
 ———— Single-cord Multiple, 262
 ———— Single-wire Multiple, Chap. xv., pp. 247-267
 ———— for Small Exchanges, Chap. xi., pp. 179-188
 ———— Chinnock, 180
 ———— "Consolidated," 180
 ———— Standard, 184
 ———— Through Switching between Sections, 206, 222
 ———— Testing of, 321, 326
 ———— Wiring of, Chap. xix. 305-313
 Switchcords, Testing of, 227
 Switching-through, Formula for Proportion of Direct Operations, 207
 ———— Methods of, 209
 Switch-springs, Grouping of, 225
 ———— Metallic Circuit Multiple, 272, 277, 285
 ———— Number of, for each Operator, 226, 260, 265, 276
 ———— Post Office Multiple, 285
 ———— Post Office, 214, 285
 ———— for Single-cord Working, 200
 ———— Single Wire, 184
 ———— Single-wire Multiple, 252
 Submarine Telephone Cables, 469
 480

Subscribers, Numbers for, 225
 Sub-trunk Wires, 336
 ———— Number for each Operator, 340
 Superposing Vibrator System on Morse Circuit, 371
 Suspenders, Aerial Cable, 430
 Symmetrical Twist of Open Wires, 412
 Saunders & Brown Signaller, 137
 Scribner's Single-cord Multiple Switch, 262
 Shaw, Frank, Inventor of Call-wire System, 232
 Siemens, Dr. Werner on Sensitiveness of Bell Telephone, 25
 ———— Armature, 122
 ———— "Head-gear" Telephone, 56
 ———— Micro-Telephone, 154
 ———— Receiver, 42
 ———— "Siren Call," 43
 ———— Table Telephone, 154
 ———— Wall Telephone, 150
 Sinclair's Call-box, Smith &, 347
 Sloper's "Secret" Switchboard, 383
 Smith and Sinclair's Call-box, 347
 Stock Exchange Call-office System, 345
 Stroh, on Theory of Microphone, 38

T

Table (Horizontal) Switchboards, 243, 299
 ———— Keys, 190, 194, 199, 283
 ———— Cam-lever, 199
 ———— Dewar, 190, 194
 ———— of Sags and Stresses, 421
 ———— Telephones, 150
 Tablets, Cable Terminal, 457
 ———— Speaking, 221
 ———— Through, 222
 "Tag" for Flexible Conductor, G. E. Co.'s, 52
 "Telegraph" Messages by Telephone, 225, 227, 228, 366
 Telegraphy and Telephony, Simultaneous, Chap. xxiv. 356-363

- Telephone Cables, Chap. xxx. 448-471
 ——— "Galvanometer," 231
 ——— Instruments, Complete, Chap. ix. 143-155
 ——— Bell-Blake, 147
 ——— Berliner's Universal, 149
 ——— Consolidated Co.'s Circular Table, 152
 ——— Ericsson-Bell Table, 151
 ——— Ericsson-Bell Wall, 149
 ——— Gower-Bell, 143
 ——— Hunning-Bell and Magneto, 148
 ——— Mix & Genest's Table, 151
 ——— Post Office, 146
 ——— Siemens' Table, 154
 ——— Siemens' Wall, 150
 ——— Western Electric Table, 150
 ———, Bell, Chap. ii. 15-29
 ——— Resistance of, 20
 ——— Theory of, 22, 27
 ———, Fixing, in Silence Cabinet, 2:8
 ——— Musical, 3
 ——— Receivers (*see* Receivers, Telephone)
 ——— Speaking, Invention of, 3
 ——— Transmitter, Invention of, 5
 ——— Transmitters (*see* Transmitters, Telephone)
 Telephonic Research, Examples of, Chap. vi. 93-102
 Tensile Strength of Wires, 438, 443, 445
 Tension-Ratchet, 419
 Terminal, Post Office Receiver, 51
 Test Boards, etc., Chap. xx. 314-328
 ——— Pegs, 326, 328
 Testing Switchboards and Lines, 321, 326
 ——— of Switchcords, 227
 Test-wire for "Engaged" Signal, 254, 264, 266, 270, 272, 282, 289, 303
 Theory of Bell Telephone, 22-25, 27-29
 ——— (Construction) Mercadier, 27
 ——— Du Moncel, 23
- Theory of Bell Telephone, Gerdaldy, 24
 ——— Mercadier, 24
 ——— of Hughes' Microphone, 37
 ——— of Magnetic Field in Bell Telephone, Heaviside, 28
 Through-switching between Sections at Exchanges, 206
 ———, Method of Operating 209
 Through Tablets, 222
 Time-constant of Circuits, 472
 Time-limit for use of Ordinary Lines, 226
 ——— Trunk Lines, 225, 341
 Toll System for Use of Telephone, 350
 Translators or Transformers, Chap. xxi. 331-340
 ——— Coleman & Jackson, 333
 ——— Elsässer's System, 335
 ——— Liverpool, 333
 ——— Ringing-through, 335
 Transmitters, Telephone—
 Ader's, 64
 Berliner's "Universal," 83
 Bert & D'Arsonval's, 65
 Berthon's, 85
 Blake, 71, 104
 ——— Switchboard, 73, 190
 Boudet's, 79
 "Breast," 299
 Bréguet's Mercury, 98
 Burnley's, 80
 Carbon, Chap. v. 60-92
 Comparative Efficiency of some, 103
 Crossley's, 61
 De Jongh's, 66
 Edison's, 31, 104
 Fitzgerald Granular, 154
 Forbes' Thermal, 101
 Freeman's, 78
 Gent's, 75
 Gower-Bell, 62
 Hughes' Microphone, 5
 Hunning's, 81, 104
 Hunning "Cone," 91
 Johnson's, 70
 Locht-Labye's, 75
 Maiche's, 74
 Microphone, Invention by Hughes

Transmitters, Telephone—

- Mix & Genest's, 68
- Moseley's, 82
- Reis', 93
- Roulez's, 83
- "Solid-Back," 89
- Thornberry's, 86
- Western Electric, 87
- Trevelyan Effect in Microphone, 39
- "Triple Switching," Prevention of, 289
- Trough, Cross-connection, 315
- Trunk Wires, 224, 295, 331, 336
- — — and Call-offices, 341
- — — Number per Operator, 340
- — — Speaking - circuit for Working, 337
- — — Time-limit for Use of, 225, 341
- Twist, Symmetrical, of open Wires, 412
- — — French System, 417

Thompson, Prof. Sylvanus P., 3
 Thomson, Sir W. (Lord Kelvin) 3

- Thornberry's Transmitter, 86
- Touanne's Calculations for Switching Efficiency, 207
- — — on the Proportion for Ring-off Indicators, 261

U.

- "Ultimate Capacity" of Multiple Switch, 258, 261
- Underground Cables, 450, 452
- "Universal" Connections for Post Office Telephones, 146, 160
- — — Set, Berliner's, 149
- — — Transmitter, Berliner's, 83

V.

- V**ibrator System, Cardew's, 367
- — — Advantages and Disadvantages, 369, 370

- V**an der Weyde, 3
- Van Rysselberghe's Simultaneous Telegraphy and Telephony, 358
- — — Anti-induction System, 357
- Varley, 3, 362

W.

- W**all Blocks and Plugs, 142
- — — Rosettes, etc., 141
- "Watch Receivers, 53
- Weight, Breaking, 444
- — — of Copper Wire Joints, 427
- — — of Mile or Knot from Short Length, 489
- — — of Receivers, 56, 57
- "Whittington" Bell, 135
- Winding of Instrument Coils, 231
- Wire Gauge, Standard, 486
- — — for Telephone Aerial Lines, Chap. xxix. 437-447
- Wiring of Switchboards, Chap. xix. 305-313
- Writing Desks for Silence Cabinets 228

- W**estern Electric Cables, 455
- — — Domestic Switchboard, 378
- — — Double-pole Receiver, 51
- — — Granular Transmitter, 87
- — — Hunning-Bell Telephone, 148
- — — Micro-Telephone, 154
- — — Multiple Switchboards, 247, 275
- — — Standard Switchboards, 184, 189
- — — Switchboard Transmitter 73
- — — Table Telephone, 150
- Weyde, Van der, 3
- Wheatstone, 1
- Williams' Automatic Cut-out for Generators, 125
- Wray, Cecil & Leonard, 3

