

C. A. BELL.

TRANSMITTER FOR ELECTRIC TELEPHONE LINES.

No. 336,081.

Patented Feb. 16, 1886.

Fig. 1.

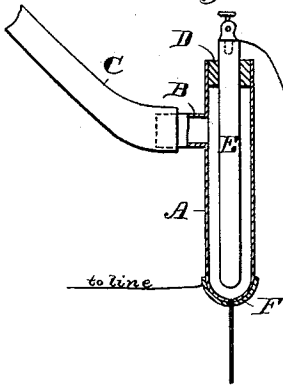

Fig. 2.

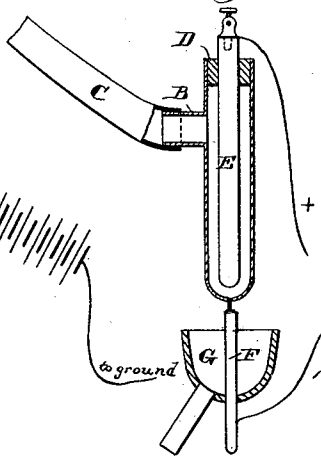

Fig. 3.

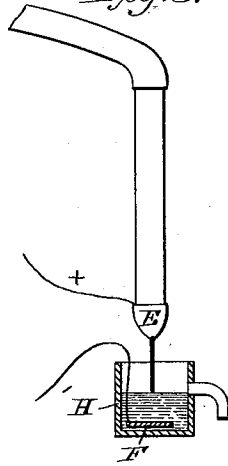

Fig. 4.

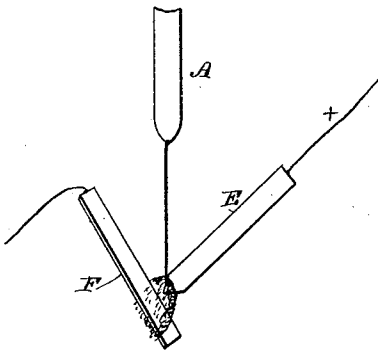

Fig. 4a.

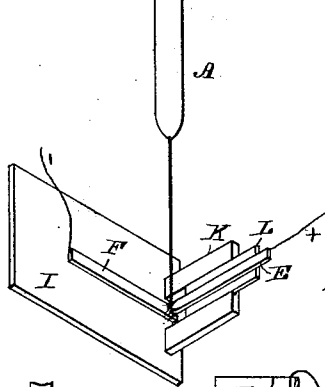

Fig. 5.

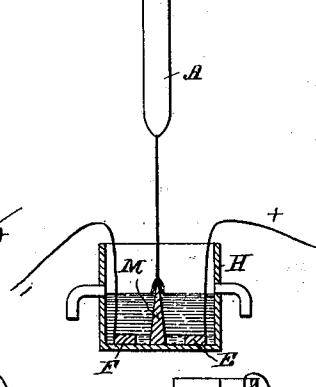

Fig. 6.

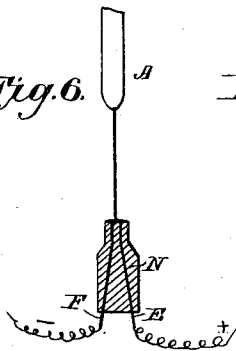

Fig. 7.

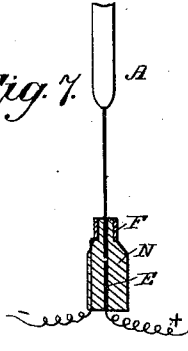

Fig. 8.

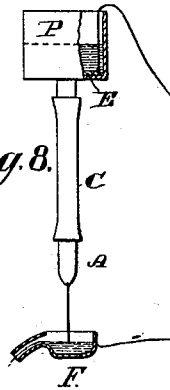
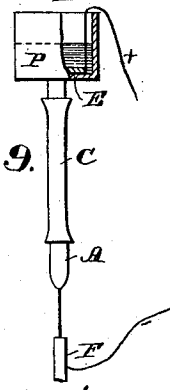

Fig. 9.



Witnesses

Geo. J. Tanner
Philip Chaud

Inventor

Chichester A. Bell by
A. Pollok
 his attorney.

C. A. BELL.

TRANSMITTER FOR ELECTRIC TELEPHONE LINES.

No. 336,081.

Patented Feb. 16, 1886.

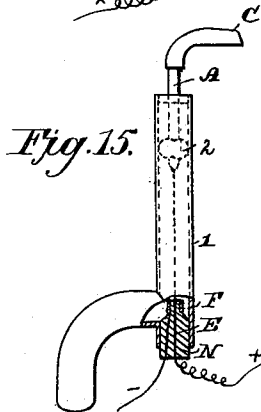
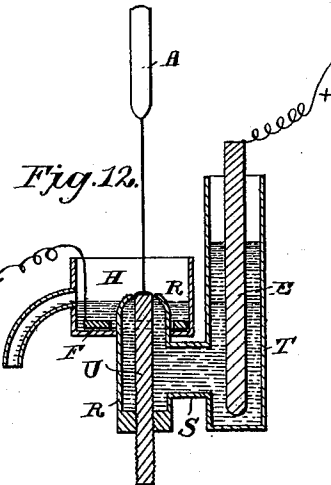
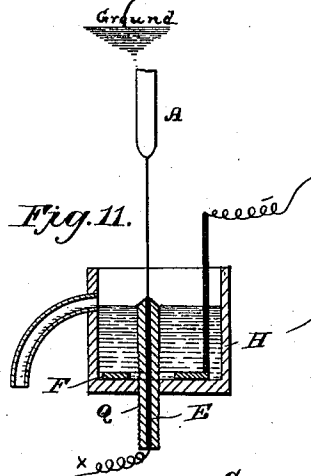
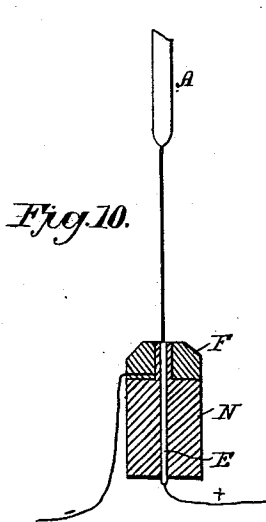
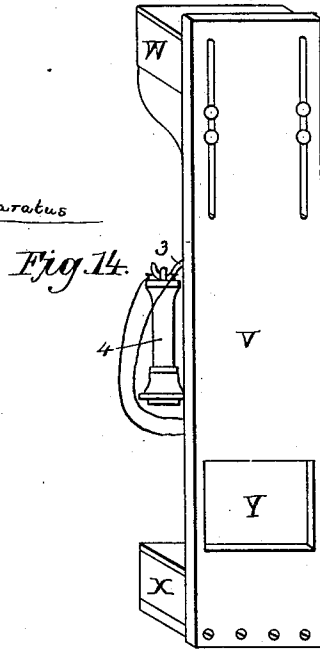
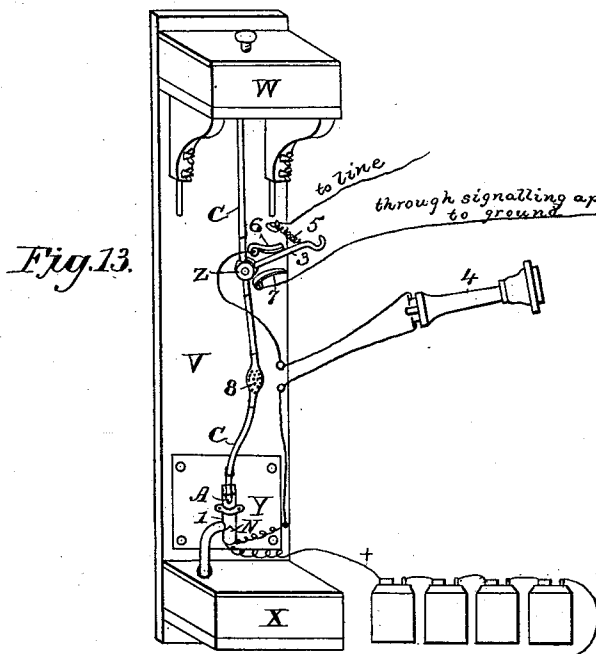

Witnesses

Jos. J. Panner
Philipbauer

Inventor

Chichester A. Bell
by *A. Pollok*
his attorney.

UNITED STATES PATENT OFFICE.

CHICHESTER A. BELL, OF WASHINGTON, DISTRICT OF COLUMBIA.

TRANSMITTER FOR ELECTRIC-TELEPHONE LINES.

SPECIFICATION forming part of Letters Patent No. 336,081, dated February 16, 1886.

Application filed May 1, 1884. Serial No. 139,947. (No model.)

To all whom it may concern:

Be it known that I, CHICHESTER A. BELL, of Washington, in the District of Columbia, have invented a new and useful Improvement in Transmitters for Electric-Telephone Lines, which improvement is fully set forth in the following specification.

This invention may be considered as an improvement upon or particular mode of carrying into effect the invention described in my application, of even date herewith, for methods of and apparatus for transmitting, reproducing, and recording speech and other sounds and signals, and for other purposes, or, in particular, that portion of said invention which relates to the production of a vibratory electric current through the medium of a sensitive jet, upon which vibrations similar in form to sound-waves or other vibrations are impressed.

The invention consists, first, in causing the vibratory jet upon which the vibrations are impressed to act directly upon a current or charge of electricity—that is to say, the variations in the electrical conditions of the jet are made effective to produce variations in the flow or distribution of electricity in a conductor connected with said jet. If the jet were allowed to fall upon the diaphragm of an ordinary telephone-transmitter, it would produce variations in the circuit controlled by said transmitter; but the action of the jet would be indirect and due to mechanical rather than electrical forces. The changes in the electrical condition of the jet are or may be utilized by including the vibratory jet, or rather a portion thereof, in a charged electric circuit, so that the resistance of the circuit is varied by the variations in the fluid conductor produced by the vibrations of the jet.

It consists, secondly, in arranging the said parts so that the portion of the jet included in the circuit is continuous, and its variations in resistance are proportionate to the vibrations impressed upon the jet, so that electrical vibrations similar in form to sound-waves may be produced upon the circuit.

It consists, thirdly, in including a portion of the jet at a distance from the jet-orifice in the circuit.

It consists, fourthly, in arranging a device in the path of the jet, so that the fluid spreads

out over it in a thin film, and including this film, which is or may be continuous in the circuit.

It consists, fifthly, in making the jet-fluid the electrolytic liquid of a galvanic cell charging the circuit, so that the internal resistance of the battery is varied; and, sixthly, it consists in the arrangement of the electrodes for including the jet in the circuit, so that the gases given off from the decomposition of an electrolysible jet of liquid are allowed to escape without interfering with the operation.

If a fluid (gas or liquid) be forced under suitable pressure, through a contracted circular orifice, the issuing jet is in the form of a smooth gradually-tapering column for a certain distance from the orifice, when it rapidly enlarges, and then breaks into drops. Noises in the neighborhood of the jet (the latter being in a sufficiently sensitive condition) disturb the even flow of the latter, and the exterior of the column becomes wavy, the waves being more pronounced as they recede from the orifice. The form of the sound-waves which created the disturbance is retained in the continuous portion of the jet; but when the latter breaks into drops the form of the vibration is destroyed, while its rhythm remains. The current to be vibrated may be passed through a considerable portion of the jet, beginning with the orifice, (the one electrode being in contact with the fluid at or behind the orifice, and the other at a point below,) and the current will be varied by the variable resistance of the fluid (liquid) due to vibrations impressed upon the jet. By placing the outer electrode in the continuous portion of the jet the form of the vibrations will be retained, and thus speech and other sounds, in contradistinction to mere tones, may be translated into electrical vibrations or undulations.

It should be here observed that jets have a natural or normal vibration, which is always very apparent in the discontinuous portion of the jet, but may in great measure be suppressed or rendered non-apparent in the continuous portion by proper insulation of the jet-orifice and regulation of the pressure. The advantage therefore of including a continuous portion of the jet in the circuit, as above specified under "secondly," is twofold—there-

2
 5 tention of the form of the vibrations, and the suppression of the normal vibration, of the jet. In the arrangement of the electrodes above indicated, however, the variation is
 10 small in proportion to the total resistance of the included portion of the jet, because, first, the variations near the orifice are small, and, second, the contractions and expansions at different points in the included portion to
 15 certain extent neutralize each other. The first difficulty is obviated by arranging both electrodes at a suitable distance from the orifice, as above specified under "thirdly," and the second partially by contracting the space between the electrodes, but best by the arrangement above specified under "fourthly," the film representing almost exactly the cross-section of the jet-column.

20 By making the electrodes the elements of a galvanic couple and the jet-liquid the excitant, as above specified under "fifthly," the effect of the variations in the jet's resistance is increased, in consequence of the diminution of the resistance of the circuit by the omission
 25 of the battery as a separate thing additional to the transmitter. At the same time the internal resistance of the battery is very high.

30 The advantage of disposing of the gases evolved by the electrolysis, as specified under "sixthly," is sufficiently obvious. It may be observed, however, generally, that the flow of the liquid will carry off the gases, so that they are not likely to collect upon the electrodes, as in the water-telephone heretofore devised
 35 by others. There is, however, very little similarity between a jet-telephone and one of these instruments.

40 In order that others may make and use the invention, several forms of apparatus embodying or constructed in accordance with all or some of the improvements specified will now be described.

45 Figures 1 to 12 illustrate different forms of appliances for including a part of the jet in circuit, so that vibrations impressed upon the jet will be translated into electric undulations or vibrations in the circuit. Fig. 13 is a perspective view of a telephone-station apparatus comprising a jet translating apparatus as the transmitter; Fig. 14, a view of the same
 50 from the opposite side, and Fig. 15 a detail view showing, on a larger scale, how the jet-tube and electrodes are supported. Figs. 1, 2, and 3 represent forms of transmitter in which the current to be varied is passed
 55 through a portion of the jet at or near the jet-orifice. Figs. 4, 4^a, 5, 6, and 7 show transmitters in which a portion of the jet at a distance from the orifice is utilized. Figs. 8 and 9 show an arrangement in which mercury is used as the jet-liquid. Figs. 10, 11, and 12 show forms of transmitters in which the jet-fluid forms part of the internal circuit of a battery.

65 In Fig. 1 the glass jet-tube A is provided with a side tube, B, fused onto it, which is connected, by means of a rubber tube, C, with

the source of liquid. The upper end of the jet-tube A is closed by a hard-rubber stopper, D, through which passes an electrode, E, 70 in the form of a metallic rod, preferably of platinum, reaching almost to the orifice. On the outside of tube A is a second electrode, F, in the form of a coating of platinum, which extends up to the edge of the orifice. The line-wires are connected to the electrodes E F, 75 respectively. The liquid used should be a conductor of electricity. Dilute sulphuric acid (say one volume of strong sulphuric acid, free from lead, mixed with three hundred volumes 80 of water) answers well. It is introduced by the supply-tube C, under a suitable head or pressure, and escapes in the form of a jet from the circular orifice in the end of the jet-tube A. A pressure of four feet of water with a 85 jet-orifice of four one-hundredths of an inch diameter answers well. With each size of jet-orifice a different pressure is required. Generally it may be said that the jet is in suitable condition when it is visibly affected by a 90 moderately-high whistle made with the mouth. The electrode E is adjustable, being held in place by friction, and can be set experimentally to give the best results in any case; but, ordinarily, it is found best to have the end 95 about one-twentieth of an inch from the bottom of the jet-tube. It will be understood that the dimensions before given, as well as this distance, may be varied within considerable limits, and that the invention is not confined thereto. It may also be said here, to 100 avoid repetition, that the dimensions given answer well with the other forms of apparatus; but for the apparatus of Figs. 6 and 7 a small jet—say, from an orifice about thirteen-thousandths ($\frac{13}{1000}$) of an inch, under a head of 105 eighteen (18) to twenty (20) inches of water—is preferred. A galvanic battery or other sufficiently constant source of electricity is included in circuit with the electrodes, and with 110 the jet-liquid between them. If, now, vibrations of any kind be communicated to the jet-tube, or to the liquid behind the jet, or even directly to the jet itself, close to but outside the orifice, the said vibrations will effect a 115 change in the resistance between the electrodes. The variation in resistance throws the electric current into corresponding vibrations, and these electrical vibrations or undulations may be rendered evident in any suitable receiving-instrument included in or connected 120 with the circuit in any ordinary or suitable way.

For transmitting speech an ordinary receiving or magneto telephone may be used, it being preferably included in the same circuit 125 with the transmitter, as hereinafter described with respect to Figs. 13 and 14. The liquid is allowed to run off, it matters not where. It should not be allowed to form a by-path to the 130 electric current. It will be most convenient to collect it in a glass vessel.

In Fig. 2 the outer coating of platinum is dispensed with, and the jet is allowed to strike

on the summit of a metallic rod placed close to the orifice. This constitutes the opposing electrode F. An ebonite cup, G, with an escape-pipe, serves to collect and carry off the jet-liquid. The current is passed from electrode E through the jet-liquid to electrode F.

In Fig. 3 the jet-tip is metallic, preferably of platinum, and serves as the electrode E. The jet strikes on the surface of the liquid in the vase H, from which it is carried off by the side tube, by which its level is kept approximately constant. The second electrode is plunged into the liquid in this vase. Platinum is recommended for the electrodes, but other metals may be used. If the metals employed are such as may be chemically acted upon by the jet-liquid under the influence of the current, it is desirable that the current should have such a direction that the electrode within the jet-tube may be least acted upon.

It has already been mentioned that when a jet strikes a flat surface it spreads out over the same in the form of a thin film, and that the vibrations of the jet are preserved in this film. When a jet of not too small diameter strikes against the surface of a smooth plate—as, for example, a plate of glass—very near its edge, it is reflected, the reflected portion taking the form of a thin sheet having a band of troubled liquid on each side. This thin sheet is continuous for a certain distance, beyond which it breaks into drops. If a second flat surface be introduced into this sheet, it will be found that the contact of the liquid with it takes the form of a sharply-defined line, on each side of which the liquid flows away as a film over the surface. In the jet-film formed in free air, as above described, the jet-vibrations are also perfectly preserved.

Fig. 4 shows an apparatus for transmitting a current through the film. The electrode E is a pointed strip of platinum foil, to which one line-terminal is connected. The jet strikes very near the pointed tip, and is reflected onto the opposing electrode F in the form of another strip. This latter is so narrow that it only comes into contact with the jet-film, and not with the columns of disturbed liquid on each side of it.

Fig. 4^a shows an apparatus by which the strip electrodes may be held in position, and the distance between them varied, so as to change the internal resistance. The electrode F is attached to a plate of ebonite, I. Another plate of ebonite, K, is attached to the plate I at right angles. The middle portion of the plate K at its base is cut away. In a groove on the upper face of said plate K is an ebonite slide, L. The electrode E is fastened on the upper face of the slide, with its tip projecting below the lower end thereof. By adjusting the position of the slide the distance between the electrodes can be regulated. The plates are shown tipped up, so that the line of their intersection is oblique to the jet. This is for the purpose of illustration. Ordinarily they would be so placed that the line of intersec-

tion would be at right angles. They may, however, be tipped up, as shown.

In Fig. 5 the jet strikes upon the upper sharp edge of an insulating-partition, M, which divides the ebonite vase or vessel H into two portions. The electrodes E and F are immersed in the liquid in the two halves of the vase. By means of overflow-pipes the level of the liquid is kept constantly below the upper edge of the partition M.

The transmitter represented in Fig. 6 is composed of a simple piece of ebonite, N, (which may conveniently have the shape shown,) through which pass the electrodes E and F in the form of platinum wires. The ends of these wires are cut off flush with the top of the ebonite plug, which is slightly rounded. The jet-fluid in spreading out over the upper end of the plug completes the circuit between the electrodes. It is advisable that these wires should come into contact only with the jet-film, and not with the troubled liquid surrounding it; hence when very small jets are employed these wires must be fine and the distance between their exposed ends very small, whereas when large jets are used they may be of larger diameter and pretty widely separated.

In Fig. 7 the electrode E, in the form of a wire, passes through the center of the ebonite plug, while the upper cylindrical end, N, is surrounded by the electrode F, in the form of a tube of platinum foil. The jet is allowed to strike upon the exposed end of the electrode E, and, spreading out, to make contact with the inclosing-electrode F. It is desirable that the upper edge of the electrode F should be in contact only with the jet-film; hence for small jets the diameter of the electrodes must be small.

In Fig. 7 the inclosing-electrode F, instead of an inclosing-tube, may be a ring of gas carbon or of any metal which may or may not be chemically acted on by the jet-liquid.

Figs. 8 and 9 show forms of apparatus for use with mercury jets. In Fig. 8 one electrode, E, dips into the mercury in the upper reservoir, P, and the mercury, after flowing through the supply-tube C and jet-tube, is received as a jet in the small metal cup which constitutes the second electrode, F. In Fig. 9 the mercury jet strikes against the summit of the electrode F, which is a rod of platinum or gas carbon.

Figs. 10, 11, and 12 show transmitters in which the jet-fluid varies the internal resistance of a galvanic cell, each transmitter being composed of two metals, which, together with the jet-liquid, form the galvanic couple.

In Fig. 10 electrode E, composed of the metal least acted upon by the liquid, passes through a plug of ebonite, glass, or other insulator, N, so that only its upper end is exposed. Surrounding the upper end of the electrode E, but insulated from it by a tubular prolongation of the insulating-plug, is the opposing electrode F, composed of a ring of the metal most acted upon. When too much corroded,

the outer metallic ring may thus be easily replaced. A central wire, of platinum, with an outer ring of zinc, and a jet of dilute sulphuric acid (1 to 300) or of solution of common salt, form an efficient arrangement. Care should be taken that no part of the electrode E, except its upper end, and no part of the wire attached thereto, shall come in contact with the liquid. The wire is or may be soldered into the zinc ring, and is or may be protected with insulating material outside of the same.

In Fig. 11 the jet strikes upon the summit of the unacted-upon element or electrode E, and, spreading out, makes contact with the liquid in the trough or vase H. The element or electrode E is surrounded by a tube, Q, of insulating material, (ebonite,) passing through the bottom of the vase H. This tube may have a thread cut on it, so that by turning it may be raised or lowered until the upper end of the insulating-tube is slightly above the level of the liquid in vase H. By means of the overflow the level of the latter is kept nearly constant. The second battery element or electrode, F, which is attacked by the jet-fluid, is placed in the vase H, and may conveniently have the form of a flat ring surrounding the electrode E and its inclosing-tube Q.

In Fig. 12 the jet-film makes contact between two masses of liquid, each having immersed in it one of the battery elements or electrodes. The apparatus is composed of a vase, H, in which is placed the element or electrode F, which is most corroded by the liquid. The overflow-pipe keeps the level of the liquid in the vase nearly constant. An ebonite tube, R, having a circular opening in the top, passes through the bottom of the vase H to such height that its summit is just above the level of the liquid therein. The tube R communicates at the bottom by means of a wide horizontal tube, S, with another tube, T, in which is placed the second battery element or electrode, E. A solid rod of ebonite, U, with slightly-rounded top, screws into the closed lower end of the tube R, and may be adjusted so that its outer edge is barely below the circular orifice at the top of the said tube R. It is made of such diameter that it leaves a very narrow annular opening at the top of tube R. The jet plays upon the summit of the ebonite rod U, and, spreading out, makes contact between the liquid inside the tube R and the liquid surrounding it. Thus neither element comes in contact with the jet-film, which is not disturbed by the escape of gases from their surface. It will be understood that the apparatus shown in Figs. 11 and 12 could be used with electrodes of non-corrodible material in connection with an exterior battery.

Figs. 13, 14, and 15 show a form of complete apparatus adapted for use on a telephone-circuit, Fig. 13 being a back view with battery-connections, &c., Fig. 14 a front view, and Fig. 15 representing a convenient method of mounting the transmitter. V is the back board or

support, of stout wood, having fixed to it above the reservoir W, and below the reservoir X. Near its base an aperture six inches square is cut, and over the back of this aperture the sounding-board Y is fastened by screws. This sounding-board is conveniently made of thin (three-eighths of an inch) pine varnished. Washers of soft rubber are placed between it and the back board or support at the four corners, so as to keep it from contact with the support, except at these points. To this sounding-board the jet-tube is attached. A separate sounding-board may, however, be dispensed with, inasmuch as the support, especially if not too thick, may well serve the purpose of imparting vibrations to the transmitter.

The vulcanite plug with the electrodes E F, as described with reference to Fig. 7, is cemented into the lower end of a glass tube, 1, which is fastened by a band of thin brass or by other suitable means to the sounding-board. A side branch of this tube, which is bent downward, serves to carry off the liquid from the transmitter. The jet-tube A is fixed in the upper part of the tube. This may be easily effected as follows: The jet-tube A is first provided with a ball-shaped collar, 2, of hard rubber, of such size as to slide stiffly inside the tube. It may then be forced into such a position that the jet issuing from the jet-tube strikes the center of the plug below, and that the breaking-point of the jet, under the influence of the loudest sound to which it is desired to subject it, does not rise above the said plug. When this position is found—which is, with a jet thirteen-thousandths ($\frac{13}{10000}$) of an inch in diameter under a pressure of eighteen (18) to twenty (20) inches, when the ends of the electrodes are from three-eighths ($\frac{3}{8}$) to one-half ($\frac{1}{2}$) of an inch from the jet-orifice—the tube 1 is filled from 2 upward with a melted cement made of beeswax, (one part, by weight,) rosin, (five parts,) and red ocher, (one part.) Although by this method of mounting, the vibrations due to the impact of the jet on the transmitter are liable to be communicated back to the orifice, with the small jets here recommended this presents no practical inconvenience. The supply-tube C leads from the bottom of the upper reservoir to the jet-tube. It is made mainly of flexible rubber tubing. In it is the valve or cock Z, which may suitably be made of ebonite. The brass arm 3 serves to open and shut this valve. It is provided at the end with a hook or fork to receive the hand telephone or receiver 4, and is combined with a retractile spring, 5, and two spring-contacts, 6 and 7. When the telephone is hung upon the arm, the latter is drawn down by the weight, and the valve is closed. When the telephone is removed, the lever-arm is drawn upward by the coiled spring 5, and the valve is opened. In the tube C, below the cock, is a filter, 8, made of a piece of glass tube loosely packed with cotton free from oily matter, and below it is the jet-tube A.

The battery-circuit is as follows: from positive pole of battery to electrode E, through the jet-film to electrode F, through the telephone 4 to contact-spring 6, and from these, when the arm 3 is up, through retractile spring 5 to line, and through a similar apparatus at the other end of the line to earth. When the arm 3 is down, the electrical connection between contact 6 and the arm is broken, and the receiving and transmitting telephones are therefore cut out of circuit. At the same time the arm 3 connects the main line to the contact 7, and thence through the signaling apparatus to ground. The signaling apparatus may be such as ordinarily used in telephone apparatus. It forms no part of the invention. It is not necessary to have more than one battery on a circuit; but when two similar transmitters are on the same circuit the battery-power or electro-motive force should be nearly double that with one only. When two batteries are used, care must be taken that the currents from both are in the same direction on the line. The variable-resistance medium, which is composed of the jet-film between the electrodes EF, is placed in the main line because the variations in resistance are so great as to bear a considerable proportion to the whole resistance of the circuit. Being adapted to operate in the main line, it may be used at the subscribers' stations in telephone-exchange systems, with a battery at the central office. The batteries at subscribers' stations may thus be dispensed with.

For an arrangement of central-office switch-board and appliances which may be used see Patent No. 252,986, of George L. Anders, dated January 31, 1882, for telephone-exchange apparatus. It will be understood, however, that it is not essential that it should be placed in the main line, but could be otherwise connected with the main line. When a current is to be varied by passing it through a mercury jet or film, the battery and conducting-wire must have the lowest resistance possible. With a mercury transmitter it is therefore preferable to include the battery-transmitter in a local circuit, the telephone and line wires being in a secondary circuit acted upon inductively by the local circuit.

The plug with electrodes arranged as shown in Fig. 6 could be substituted in Figs. 13 to 15 for the one there shown without further change in the apparatus.

Instead of the forms of apparatus shown in Figs. 6 and 7, any of the other forms could be used in the apparatus shown in Figs. 13 and 14. Any suitable means may be used to throw the jet into vibrations. Several forms of such means are shown in my applications filed of even date herewith and officially numbered 129,946 and 129,948, the present application being No. 129,947. All these forms are suitable for use with the means herein described for translating the jet-vibrations into electrical vibrations or undulations. It will be understood, therefore, that the invention is not

limited to the particular manner or means described for impressing vibrations upon the jet, the description and illustration thereof being merely by way of example.

It is evident, as well from the general nature of the subject-matter as from the description given above of the various forms of apparatus, that modifications may be made in details without departing from the spirit of the invention, and that portions of the invention may be used separately.

In the foregoing specification it has been said that the vibrations in the jet alter the resistance of the circuit which includes it. It should, however, be understood that it is not thereby intended to limit the invention by any theory of the electrical forces brought into action.

Having now fully described my said invention and the manner of carrying the same into effect, what I claim is—

1. The method of producing electrical vibrations in a conductor by impressing corresponding vibrations upon a jet connected with the charged conductor, and by the variations in the electrical condition of the jet altering the current or charge in the conductor connected with it, substantially as described.

2. The method of producing electrical vibrations similar in form to sound-waves, by impressing the sonorous vibrations upon a conducting-jet having the continuous portion thereof included in a charged conductor, and thereby varying the current or electrical charge in said conductor, substantially as described.

3. The method of producing electrical vibrations in a conductor by producing a jet of a liquid adapted to serve as the excitant in a galvanic couple, causing said liquid to complete the circuit between the elements of a galvanic couple connected with said conductor, impressing the vibrations upon said jet, and thereby varying the current charging said conductor, substantially as described.

4. The method of producing undulations in an electric current by causing a jet of conducting-liquid to play upon a body in the path of the jet, so as to spread the jet-liquid into a film, and communicating the vibrations to the current from the vibrations in the film, substantially as described.

5. The method of producing undulations in an electric current by impressing vibrations upon a jet of conducting-liquid at a suitable point, and communicating similar vibrations to the current directly from the jet-fluid at a part of the jet farther removed from the orifice, substantially as described.

6. In combination with means for producing a jet, electrodes for including a portion of the jet so produced in an electric circuit, substantially as described.

7. In combination with means for producing a sensitive vibratory jet, electrodes for including a continuous portion of said jet in an electric circuit, substantially as described.

8. In combination with means for producing a vibratory jet, electrodes arranged both at a distance from the jet-orifice for including a portion of said jet in an electric circuit, substantially as described.

9. In combination with means for producing a jet, a body arranged in the path of said jet, and means for including in circuit the film which spreads out over said body, substantially as described.

10. Electrodes constituting elements of a voltaic couple, in combination with means for producing and directing a jet of an excitant liquid, so as to complete the circuit between the electrodes through a portion of the jet, substantially as described.

11. In combination with means for producing a jet, a solid conductor or electrode in electrical connection through a body of liquid with the jet-liquid, substantially as described.

12. The combination, with means for pro-

ducing a jet, of the conductors or electrodes embedded in a plug of insulating material, and arranged to be connected through the jet, substantially as described.

13. In an electric speaking-telephone transmitter, the variable-resistance medium composed of a conducting-fluid in constant flow, in combination with electrodes for including such fluid in circuit, substantially as described.

14. The combination, with a telephone-transmitter having a conducting-fluid in constant flow as the variable-resistance medium, of a battery, a receiving-telephone, and a telephone-line, substantially as described.

In testimony whereof I have signed this specification in the presence of two subscribing witnesses.

CHICHESTER A. BELL.

Witnesses:

C. J. HEDRICK,
PHILIP MAURO.